



2020

---

Guidance for  
Fuel Cell Systems on Board of  
Ships

---

KR



2020

---

Guidance for  
Fuel Cell Systems on Board of  
Ships

## APPLICATION OF "GUIDANCE FOR FUEL CELL SYSTEMS ON BOARD OF SHIPS"

1. Unless expressly specified otherwise, the requirements in the Guidance apply to fuel cell systems on board of ships for which contracts for construction are signed on or after 1 July 2020.
2. The amendments to the Guidance for 2015 edition and their effective date are as follows;

Effective Date 1 July 2020 (base on contract date for construction)

- The Guidance for Fuel Cell Systems on Board of Ships have been totally revised reflecting IMO draft of interim guidelines for the safety of ships using fuel cell power installations.

# CONTENTS

<b>CHAPTER 1 GENERAL</b> .....	<b>1</b>
Section 1 General .....	1
<b>CHAPTER 2 CONSTRUCTION AND INSTALLATION (2020)</b> .....	<b>5</b>
Section 1 General .....	5
Section 2 Design Principles for Fuel Cell Power Installations .....	5
Section 3 Fire Safety .....	7
Section 4 Electrical Systems .....	8
Section 5 Control, Monitoring and Safety Systems .....	8
Section 6 Fuel Cells and Associated Components .....	9
Section 7 Manufacture, Workmanship and Testing .....	10

# CHAPTER 1 GENERAL

## Section 1 General

### 101. Application (2020)

1. This Guidance is to apply to with fuel cell power installations on board of ships used as auxiliary or main source of power.
2. The scope of this Guidance covers the requirements for the arrangement and design of fuel cell power installations in **102. 3 (4)** and the spaces containing such installations. Regulations such as storage, preparation, distribution, etc. of fuel outside the above scope are to be covered by the relevant regulations of **Rules for Ships using Low-flashpoint Fuels** depending on the fuel used. Additional safety considerations may be required when using rich hydrogen reformed fuel as fuel in fuel cells.
3. Items not specified in this Guidance relating to fuel cell power installation are to be in accordance with each relevant requirement in **Rules for the Classification of Steel Ships** except for the requirements inapplicable to fuel cell power installations in ships.
4. Items not included in this Guidance may comply with ISO, IEC, KS or equivalent standards as deemed appropriate by the Society.
5. Additional requirements to this Guidance may be required.
6. Where fuel cell power installations on board of ships are intended, those are to be accepted by the flag state in advance.

### 102. General (2020)

#### 1. Goal

The goal of this Guidance is to provide safe and reliable delivery of electrical and/or thermal energy through the use of fuel cell technology.

#### 2. Functional requirements

This Guidance is related to the goals and functional requirements of **Rules for Ships using Low-flashpoint Fuels**. In particular, the following apply.

- (1) The safety, reliability and dependability of the systems are to be equivalent to those achieved with new and comparable conventional oil-fuelled main and auxiliary machinery installations, regardless of the specific fuel cell type and fuel.
- (2) The probability and consequences of fuel related hazards are to be limited to a minimum through arrangement and system design, such as ventilation, detection and safety actions. In the event of gas leakage or failure of the risk reducing measures, necessary safety actions are to be initiated.
- (3) The design philosophy is to ensure that risk reducing measures and safety actions for the fuel cell power installation do not lead to an unacceptable loss of power.
- (4) Hazardous areas are to be restricted, as far as practicable, to minimize the potential risks that might affect the safety of the ship, persons on board and equipment.
- (5) Equipment installed in hazardous areas is to be minimized to that required for operational purposes and is to be suitably and appropriately certified.
- (6) Fuel cell spaces are to be configured to prevent any unintended accumulation of explosive, flammable or toxic gas concentrations.
- (7) System components are to be protected against external damages.
- (8) Sources of ignition in hazardous areas are to be minimized to reduce the probability of explosions.
- (9) Piping systems and overpressure relief arrangements that are of suitable design, construction and installation for their intended application is to be provided.
- (10) Machinery, systems and components are to be designed, constructed, installed, operated, maintained and protected to ensure safe and reliable operation.

- (11) Fuel cell spaces are to be arranged and located such that a fire or explosion in either will not lead to an unacceptable loss of power or render equipment in other compartments inoperable.
- (12) Suitable control, alarm, monitoring and shutdown systems are to be provided to ensure safe and reliable operation.
- (13) Fixed leakage detection suitable for all spaces and areas concerned is to be arranged.
- (14) Fire detection, protection and extinction measures appropriate to the hazards concerned are to be provided.
- (15) Commissioning, trials and maintenance of fuel systems and gas utilization machinery are to satisfy the goal in terms of safety, availability and reliability.
- (16) The technical documentation is to permit an assessment of the compliance of the system and its components with the applicable rules, guidelines, design standards used and the principles related to safety, availability, maintainability and reliability.
- (17) A single failure in a technical system or component is not to lead to an unsafe or unreliable situation.
- (18) Safe access is to be provided for operation, inspection and maintenance.

### 3. Definitions

For the purpose of these Guidances, the terms used have the meanings defined in the following paragraphs. Terms not defined have the same meaning as in **SOLAS chapter II-2** and **Rules for Ships using Low-flashpoint Fuels**.

- (1) **Fuel cell** is a source of electrical power in which the chemical energy of a fuel cell fuel is converted directly into electrical and thermal energy by electrochemical oxidation.
- (2) **Fuel reformer** is the arrangement of all related fuel-reforming equipment for processing gaseous or liquid primary fuels to reformed fuel for use in the fuel cells.
- (3) **Fuel cell power system** is the group of components which may contain fuel or hazardous vapours, fuel cell(s), fuel reformers, if fitted, and associated piping systems.
- (4) **Fuel cell power installation** is the fuel cell power system and other components and systems required to supply electrical power to the ship. It may also include ancillary systems for the fuel cell operation. (refer to **Fig 1.1**)

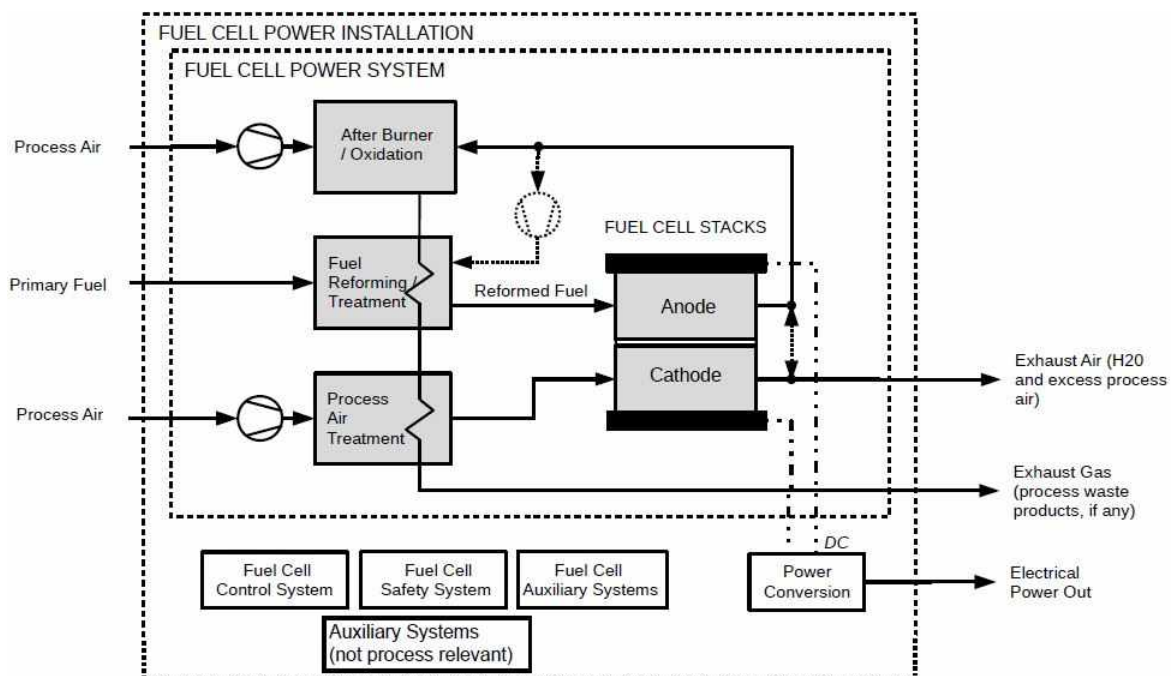

Fig 1.1 Components of Typical Fuel Cell Power Installation

- (5) **Fuel cell space** is a space containing fuel cell power systems or parts of fuel cell power systems. (refer to **Fig 1.2**)
- (6) **Reformed fuel** is hydrogen rich gas generated in the fuel reformer.
- (7) **Primary fuel** is fuel supplied to the fuel cell power system.

- (8) **Exhaust gas** is exhaust from the reformer or anode side of the fuel cell.
- (9) **Exhaust air** is exhaust from the cathode side of the fuel cell.
- (10) **Process air** is air supply to the reformer and/or the cathode side of the fuel cell.
- (11) **Ventilation air** is air used to ventilate the fuel cell space.

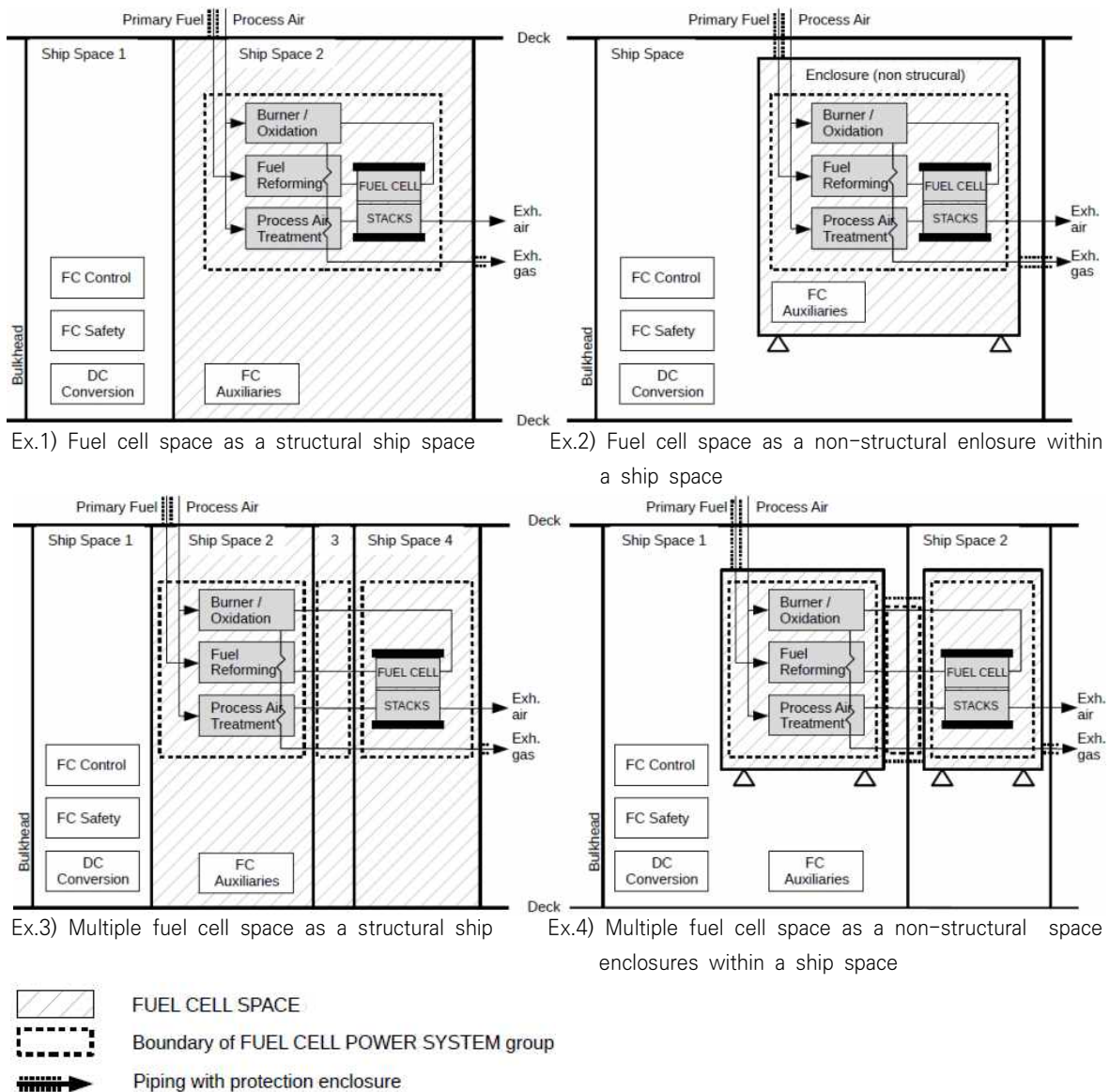

Fig 1.2 Examples for Fuel Cell Spaces

103. Class notations

1. Fuel cell power installations used as auxiliary or main source of power is to comply with this Guidances and is to be given a notation as additional special feature notations as follows:
  - (1) Where the fuel cell power is used for propulsion, essential or emergency services, a notation "FC-PWR" is to be assigned.
  - (2) Where the fuel cell power is not used for propulsion, essential or emergency services, a notation "FC" is to be assigned.

104. Alternative design (2020)

1. These Guidances contain functional requirements for all appliances and arrangements related to the usage of fuel cell technology.
2. Appliances and arrangements of fuel cell power systems may deviate from those set out in these

---

Guidances, provided such appliances and arrangements meet the intent of the goal and functional requirements concerned and provide an equivalent level of safety of the relevant sections.

3. The equivalence of the alternative design is to be demonstrated as specified in **SOLAS Reg. II-1/55** and approved by the Society. However, the Society is not to allow operational methods or procedures to be applied as an alternative to a particular fitting, material, appliance, apparatus, item of equipment or type thereof which is prescribed by these Guidances.

#### **105. Exclusion from the Guidance**

The Society cannot assume responsibility for other technical characteristics for fuel cell systems not covered by this Guidance. However, the Society may advise on such matters upon application. ⚡



## CHAPTER 2 CONSTRUCTION AND INSTALLATION (2020)

### Section 1 General

#### 101. General

1. For any new or altered concept or configuration, a risk assessment in accordance with **Ch 3, Sec 2** of **Rules for Ships using Low-flashpoint Fuels** is to be conducted in order to ensure that any risks arising from the use of the fuel cell systems affecting persons on board, the environment, the structural strength and the integrity of the ship are addressed. Consideration is to be given to the hazards associated with installation, operation, and maintenance, following any reasonably foreseeable failure.
2. In case where the power supply to propulsion or essential service is delivered by the fuel cell system, this power supply to propulsion or essential service is to be maintained in accordance with **Pt 6, Ch 1, 1601. 3** of **Rules for the Classification of Steel Ships** even if one component of the fuel cell installation becomes inoperative.
3. If the power from the fuel cell is needed for restoration of power in a black out or dead ship situation, the recovery arrangements have to be documented and approved in each case.

### Section 2 Design Principles for Fuel Cell Power Installations

#### 201. Fuel cell spaces

##### 1. Fuel cell space concept

In order to minimize the probability of a gas explosion in a fuel cell space, it is to meet the requirements of this section, or an equivalent safety concept. The fuel cell space concept is such that the space is designed to mitigate hazards to non-hazardous levels under normal conditions, but under certain abnormal conditions may have the potential to become hazardous. In the event of abnormal conditions involving gas hazards, emergency shutdown (ESD) of non-safe equipment (ignition sources) and components is to be automatically executed while equipment or components in use or active during these conditions are to be of a certified safe type.

2. Electrical installations and equipment are to comply with the requirements in **Sec 4**.
3. Within the fuel cell space concept, a single failure may result in a release of primary fuel, reformed fuel or hazardous gases into the space. Ventilation or inerting, if necessary, are designed to accommodate a probable maximum leakage scenario due to technical failures.
4. Failures leading to dangerous gas concentrations, e.g. gas pipe ruptures or blow out of gaskets are covered by explosion pressure relief devices and ESD arrangements.

#### 202. Arrangement and access

1. Fuel cell power installations are to be designed for automatic operation and equipped with all the monitoring and control facilities required for safe operation of the system.
2. It is to be possible to shut down the fuel cell power system from an easily accessible location outside the fuel cell spaces.
3. Means to safely remove the primary and reformed fuel from the fuel cell power system are to be provided.
4. Means are to be provided to set a fuel cell power installation into a safe state for maintenance and shutdown.
5. For the auxiliary systems of the fuel cell power system where primary fuel or reformed fuel may leak directly into a system medium (e.g. cooling water), such auxiliary systems are to be equipped with appropriate extraction and detection means fitted as close as possible after the media outlet

from the system in order to prevent gas dispersion. Gas extracted from the auxiliary system media is to be vented to a safe location on the open deck.

6. The reforming equipment, if fitted, may be an integrated part of the fuel cell or arranged as an independent unit with reformed fuel piping connected to the fuel cells.
7. Fuel cell spaces boundaries are to be gastight towards other enclosed spaces in the ship.
8. Fuel cell spaces are to be arranged outside of accommodation spaces, service spaces, machinery spaces of category A and control stations.
9. Fuel cell spaces are to be designed to safely contain fuel leakages and be provided with suitable leakage detection systems. Fuel cell spaces are to be arranged to avoid the accumulation of hydrogen-rich gas by having simple geometrical shape and no obstructing structures in the upper part.
10. Fuel cell spaces containing fuel reformers are to also comply with the requirements relevant for the primary fuel.
11. Where an independent and direct access to the fuel cell spaces from the open deck cannot be arranged, access to fuel cell spaces is to be through an airlock. For fuel cell spaces too small to be entered, the requirement for an airlock may be waived, subject to approval by the Administration. However, such fuel cell spaces are to be gas-freed before opening.

### 203. Atmospheric control of fuel cell spaces

#### 1. General

Protection of fuel cell spaces by an external boundary that encloses components where fuel is fed can be achieved by ventilation or inerting. These methods are to be equally acceptable to ensure the safety of the space.

#### 2. Ventilation of fuel cell spaces

- (1) Fuel cell spaces are to be equipped with an effective mechanical ventilation system to maintain underpressure of the complete space, taking into consideration the density of potentially leaking fuel gases.
- (2) For fuel cell spaces on open decks, overpressure ventilation may be considered.
- (3) The ventilation rate in fuel cell spaces is to be sufficient to dilute the gas/vapour concentration below the flammable range in all maximum probable leakage scenarios due to technical failures.
- (4) Any ducting used for the ventilation of fuel cell spaces is not to serve any other space.
- (5) Ventilation ducts from spaces containing reformed fuel piping or release sources are to be vertical or steadily ascending and without sharp bends in order to avoid any possibility for gas to accumulate.
- (6) Two fans are to be installed for the ventilation of the fuel cell space with 100% capacity each. Both fans are to be supplied from separate circuits. In case of failure of one fan, automatic change-over to the other fan shall be provided and indicated by an alarm.
- (7) In case of loss of ventilation or loss of negative pressure in the fuel cell space, the fuel cell power system is to carry out an automatic, controlled shutdown of the fuel cell and isolation of the fuel supply.
- (8) Ventilation air inlets for fuel cell spaces are to be taken from areas which, in the absence of the considered inlet, would be non-hazardous.
- (9) Ventilation air inlets for non-hazardous enclosed spaces are to be taken from non-hazardous areas located at least 1.5 m away from the boundaries of any hazardous area.
- (10) Ventilation air outlets from fuel cell spaces are to be located in an open area which, in the absence of the considered outlet, would be of the same or lesser hazard than the ventilated space.

#### 3. Inerting of fuel cell spaces

Inerting is to be accepted for atmospheric control of the fuel cell spaces provided all of the followings.

- (1) Protection by inerting is only acceptable where a fuel cell space is too small to be entered and sealing arrangements are to ensure that leakages of inert gas to adjacent spaces are prevented.
- (2) The pressure of inerting media is to always be kept positive and monitored.
- (3) Any change in the pressure, indicating a breach of the external outer boundary of fuel cell

- space, or a breach of the boundary with a space where fuel is flowing (e.g. fuel cell stack, reformer, etc.) is to activate a controlled shut-off of the fuel supply.
- (4) Fuel cell space shall be equipped with a mechanical ventilation to evacuate inerting agent, after an inerting release have been initiated.
  - (5) Inerting system shall not be operable under ongoing maintenance or inspection.

#### 204. Materials

1. The materials within the fuel cell power installation are to be suitable for the intended application and are to comply with recognized standards.
2. The use of combustible materials within the fuel cell power system is to be kept to a minimum.

#### 205. Piping arrangement for fuel cell power system

All pipes containing reformed fuel for fuel cell power systems, where fitted, is to:

1. not be led through enclosed spaces outside of fuel cell spaces;
2. be fully welded as far as practicable; and
3. be arranged to minimize the number of connections; and
4. use suitable materials to prevent any deterioration owing to hydrogen embrittlement, as necessary, at places where contact with hydrogen is anticipated. For example, austenitic stainless steel of 304, 316, 304L and 316L etc. may be used.

#### 206. Exhaust gas and exhaust air

Exhaust gases and exhaust air from the fuel cell power systems are not to be combined with any ventilation except ventilation serving fuel cell spaces, and are to be led to a safe location in the open air.

## Section 3 Fire Safety

#### 301. General provisions on fire and explosion safety

Fuel cell spaces are to be designed to provide a geometrical shape that will minimize the accumulation of gases or formation of gas pockets.

1. The fuel cell space is to be regarded as a machinery space of category A according to **SOLAS II-2** for fire protection purposes. A fuel cell space is to be bounded by A-60 class divisions. Where this is deemed to be impracticable, the Society may approve alternative boundary designs that provide for an equivalent level of safety. The fire-extinguishing system is to be suitable for use with the specific fuel and fuel cell technology. The Society may allow any alternative fire safety measures if the equivalence of the measure is demonstrated by a risk assessment considering the characteristics of fuels for use.

#### 302. Fire and explosion protection

Fuel cell spaces separated by a single bulkhead are to have sufficient strength to withstand the effects of a local gas explosion in either space, without affecting the integrity of the adjacent space and equipment within that space.

#### 303. Fire extinguishing

The fire-extinguishing system is to be suitable for use with the specific fuel and fuel cell technology proposed.

## Section 4 Electrical Systems

### 401. General provisions on electrical systems

1. Electrical equipment is not to be installed in hazardous areas unless essential for operational purposes or safety enhancement.
2. Where electrical equipment including components of fuel cell systems is installed in hazardous areas, it is to be selected, installed and maintained in accordance with IEC 60079 and IEC 60092-502 or standards at least equivalent to those.
3. Means are to be provided for protection of the fuel cell installation against short circuits and flow of reverse current.

### 402. Area classification

1. In order to facilitate the selection of appropriate electrical apparatus and the design of suitable electrical installations, hazardous areas are divided into zones 0, 1 and 2, according to **2**. In cases where the prescriptive provisions in **2** are deemed to be inappropriate, area classification according to IEC 60079-10 is to be applied with special consideration by the Society.

#### 2. Definition of zones

- (1) Hazardous areas zone 0  
The interiors of buffer tanks, reformers, pipes and equipment containing low-flashpoint fuel or reformed fuel, any pipework of pressure-relief or other venting.
  - (2) Hazardous areas zone 1
    - (A) Areas on open deck, or semi-enclosed spaces on deck, within 3 m of any reformed fuel or purge gas outlets or fuel cell space ventilation outlets;
    - (B) Fuel cell exhaust air and exhaust gas outlets;
    - (C) Areas on open deck or semi-enclosed spaces on deck within 1.5 m of fuel cell space entrances, fuel cell space ventilation inlets and other openings into zone 1 spaces;
    - (D) Areas on open deck or semi-enclosed spaces within 3 m in which other sources of release of reformed fuel are located; and
    - (E) Fuel cell spaces.
  - (3) Hazardous areas zone 2
    - (A) Areas within 1.5 m surrounding open or semi-enclosed spaces of zone 1 as specified above, if not otherwise specified; and
    - (B) Air locks.
3. Ventilation ducts are to have the same area classification as the ventilated space.

## Section 5 Control, Monitoring and Safety Systems

### 501. General provisions on control, monitoring and safety systems

1. For gas detection, requirements of **Ch 15, Sec 8 of Rules for Ships using Low-flashpoint Fuels** are applicable.
2. Chemical reactions, such as those taking place during fuel reforming, if fitted, or within the fuel cell, are to be monitored, e.g. by means of temperature, pressure or voltage monitoring.

### 502. Fuel cell power installation - safety

If limit values determined for the control process, e.g. temperature, pressure, voltage, gas concentrations which may lead to hazardous situations are exceeded, the fuel cell power system is to be automatically shut down and interlocked by an independent protective device.

1. All pipes containing reformed fuel for fuel cell power systems, where fitted, are to use fixed hydrogen detectors being capable of detecting a hydrogen leak for places where leakage of hydrogen may occur, such as valves, flanges and seals.
2. The fuel cell is to be monitored to the extent necessary to avoid that the safety is impaired.

3. A failure mode and effect analysis examining all possible faults affecting the fuel cell operation and safety is to be submitted. Based on the outcome of the analysis the extent of the monitoring and control is to be decided.
- (1) As a minimum, the following items must typically be monitored:
    - (A) cell voltage
    - (B) cell voltage deviations
    - (C) exhaust gas temperature
    - (D) temperature in FC
    - (E) current level.
  - (2) Other typical monitoring that are to be considered:
    - (A) air flow
    - (B) air pressure
    - (C) cooling medium flow, pressure, temperature (if used)
    - (D) fuel flow
    - (E) fuel temperature
    - (F) fuel pressure
    - (G) gas detection in exhaust gas
    - (H) water system level
    - (I) water system pressure
    - (J) water system purity
    - (K) parameters necessary to monitor lifetime/deterioration.

## Section 6 Fuel Cells and Associated Components

### 601. General

1. For the fuel cell module, the requirements in KS C IEC 62282-2 "Fuel cell technology-Sec.2: fuel cell module" or equivalent standards may be complied with, but will also have to take the environmental and operating conditions in a ship into account.

### 602. Fuel Reformer Systems

#### 1. General

- (1) Fuel reformer systems are to be designed for automatic operation and equipped with all the indicating and control facilities required for assessment and control of the process.
- (2) The chemical processes taking place within the unit are to be monitored.
- (3) If limit values determined for the control process are exceeded, the unit must be switched off and inter-locked by an independent protective device.
- (4) It is to be possible to switch off the reformer unit from a permanently accessible point outside the installation space.
- (5) If high surface temperatures may occur, the corresponding insulation or contact protection is to be provided.

#### 2. Firing equipment

- (1) Firing equipment in fuel reformer systems is to be designed for automatic operation. Manual operation (even for emergencies) is not permissible.
- (2) The combustion chamber and the exhaust gas system is to be purged with air or an inerting medium after the firing equipment is switched off.
- (3) The firing equipment is to be equipped with a type approved burner control box and flame monitoring devices. Reliable operation of the flame monitoring devices is to be verified for the corresponding type of fuel and mode of combustion.
- (4) The Society may require additional requirements for the firing equipment depending on the type of fuel and the burner.

#### 3. Catalytic converters

Catalytic converters in fuel reformer is to consider the environmental conditions, especially the requirements related to vibration loading.

#### 4. Gas purification

The gas purity required for the operation of the fuel cell is to be monitored by suitable methods. If the determined limit values are exceeded, an alarm is to be generated or the system is to be switched off. If this requirement is not met for installations, verification shall be provided that no additional hazard can occur through inadmissible impurities.

#### 5. Residual gases

The recirculation of fuel (residual gas) from the FC to the reformer is permissible. The recirculation is to be protected by an automatic shut-off valve.

## Section 7 Manufacture, Workmanship and Testing

### 701. General

1. Valves containing reformed fuel are to be tightness tested with hydrogen or an appropriate test gas to show that there is no leakage. After assembly, piping systems containing reformed fuel are to be tightness tested with hydrogen or an appropriate test gas to show that there is no leakage.
2. Expansion bellows for fuel cell fuel system are subject to type approval.
3. The fuel cell power systems are to be subjected to type approval, and the type tests are to be in accordance with the IEC 62282-3-100 "Stationary fuel cell power systems-Safety", but will also have to take the environmental and operating conditions in a ship into account.

### 702. Shop tests of fuel cell power installation

1. Each fuel cell power system subjected to the type approval is to be performed following tests before installation onboard. (Refer to IEC 62282-3-100, para. 6)
  - (1) Gas leakage tests
  - (2) Normal operation test
  - (3) Dielectric strength tests
  - (4) Burner operating tests

### 703. Onboard tests of fuel cell power installation

1. Before the tests commence, a detailed test programme is to be submitted and approved.
2. The fuel cell power installation is to be subjected to the following tests after installation on board: However, the items to be tested during sea trial may be included in sea trial program.
  - (1) Functional trials of components :
 

Safety shut-off valves, automatic shut-off valves, level indicators, temperature measurement devices, pressure gauges, gas detection systems and alarm devices shall be subjected to a functional trial.
  - (2) Trials of the protective devices and system :
 

During the trial, it is to be verified that, in the event of the following faults, the fuel cell power installation is automatically transferred into a safe condition:

    - (A) Alarm of the fire detection devices
    - (B) Alarm of the gas detection system
    - (C) Failure of the power supply
    - (D) Failure of the programmable logic controllers(PLCs)
    - (E) Faults in the protective devices or system

It is to be verified that the requirements of the risk analysis performed as per **Ch 2, 101. 1**, are met.
  - (3) Functional trials of the fuel cell power installation
 

The following operating conditions of the fuel cell power installation is to be tested (as far as applicable):

    - (A) Automatic start-up of the fuel cell power installation
    - (B) Operational switch-off of the fuel cell power installation
    - (C) Load change, load steps

- (D) Load shedding
  - (E) Switch-off during system malfunctions that do not endanger the safety of persons and equipment
- (4) Functional trials of the ship
- Within the scope of the functional trials, the interaction of the fuel cell power installation with the ship systems is to be tested as follows (as far as applicable):
- (A) Power generation by the fuel cell power installation alone
  - (B) fuel cell power installation together with conventional shipboard generation of electrical power
  - (C) fuel cell power installation together with batteries
  - (D) Change-over to the emergency source of electrical power
  - (E) Switching the fuel cell power installation online or offline
- If the fuel cell power installation constitutes the main propulsion system of the ship, it is to be verified that the ship has adequate propulsion power in all maneuvering situations. ↓

---

---

## GUIDANCE FOR FUEL CELL SYSTEM ON BOARD OF SHIPS

Published by

**KR**

36, Myeongji ocean city 9-ro, Gangseo-gu,  
BUSAN, KOREA

TEL : +82 70 8799 7114

FAX : +82 70 8799 8999

Website : <http://www.krs.co.kr>

---

---

Copyright© 2020, **KR**

Reproduction of this Guidance in whole or in parts is  
prohibited without permission of the publisher.