

2019

Rules for the Classification of Steel Ships

Part 4 Hull Equipment

---

---

**Rules**

2019

Guidance Relating to the Rules for the Classification of Steel ships

Part 4 Hull Equipment

---

---

**Guidance**



**2019**

**Rules for the Classification of Steel Ships**

---

**Part 4**

**Hull Equipment**

## **APPLICATION OF PART 4 "HULL EQUIPMENT"**

1. Unless expressly specified otherwise, the requirements in these Rules apply to ships for which contracts for construction are signed on or after 1 July 2019.
2. The amendments to the Rules for 2018 edition and their effective date are as follows;

**Effective Date 1 January 2019**

---

### **CHAPTER 2 HATCHWAYS AND OTHER DECK OPENINGS**

- Section 5 Hatch cover details – Closing Arrangement, Securing Devices and Stoppers
- 507. Table 4.2.11 has been amended.

**Effective Date 1 July 2019**

---

### **CHAPTER 1 RUDDERS**

- Section 6 Rudder Plates, Rudder Frames and Rudder Main Pieces
- 603. 3 & 4 have been amended.
  - 605. 1 has been amended.
- Section 7 Couplings between Rudder Stocks and Main Pieces
- 703. 2 (6) & (7) have been amended.
- Section 8 Pintles
- 802. 5 has been amended.

### **CHAPTER 8 EQUIPMENT NUMBER AND EQUIPMENT**

- Section 4 Chains
- 410. 1 (3) has been newly added.
- Section 5 Steel Wire Ropes
- 504. 1 & Table 4.8.12 have been amended.

# CONTENTS

<b>CHAPTER 1</b>	<b>RUDDERS</b>	<b>1</b>
Section 1	General	1
Section 2	Rudder Force	3
Section 3	Rudder Torque	5
Section 4	Rudder Strength Calculation	8
Section 5	Rudder Stocks	8
Section 6	Rudder Plates, Rudder Frames and Rudder Main Pieces	9
Section 7	Couplings between Rudder Stocks and Main Pieces	13
Section 8	Pintles	17
Section 9	Bearings of Rudder Stocks and Pintles	18
Section 10	Rudder Accessories	19
Section 11	Propeller Nozzles	19
<b>CHAPTER 2</b>	<b>HATCHWAYS AND OTHER DECK OPENINGS</b>	<b>21</b>
Section 1	General	21
Section 2	Design Load	23
Section 3	Hatch cover strength criteria	29
Section 4	Hatch Coamings strength criteria	45
Section 5	Hatch cover details - Closing Arrangement, Securing Devices and Stoppers	49
Section 6	Hatch ways closed by Portable Hatch Cover and weathertightened by Tarpaulins and Battens	54
Section 7	Miscellaneous Openings	56
<b>CHAPTER 3</b>	<b>BOW DOORS, SIDE AND STERN DOORS</b>	<b>59</b>
Section 1	Bow Doors and Inner Doors	59
Section 2	Side and Stern Doors	68
<b>CHAPTER 4</b>	<b>BULWARKS, FREEING PORTS, SIDE SCUTTLES, RECTANGULAR WINDOWS, SKYLIGHTS, VENTILATORS AND PERMANENT GANGWAYS</b>	<b>75</b>
Section 1	Bulwarks and Guardrails	75
Section 2	Freeing Ports	76
Section 3	Side Scuttles, Rectangular Windows and Skylights	77
Section 4	Ventilators	81
Section 5	Permanent Gangways	82
<b>CHAPTER 5</b>	<b>MASTS AND DERRICK POSTS</b>	<b>83</b>
<b>CHAPTER 6</b>	<b>CEILINGS AND SPARRINGS</b>	<b>83</b>
<b>CHAPTER 7</b>	<b>CEMENTING AND PAINTING</b>	<b>83</b>
<b>CHAPTER 8</b>	<b>EQUIPMENT NUMBER AND EQUIPMENT</b>	<b>85</b>
Section 1	General	85

Section 2	Equipment Number .....	87
Section 3	Anchors .....	91
Section 4	Chains .....	98
Section 5	Steel Wire Ropes .....	109
Section 6	Fibre Ropes .....	114
Section 7	Hatch Tarpaulins .....	116
Section 8	Side Scuttles .....	117
Section 9	Rectangular Windows .....	121
<b>CHAPTER 9</b>	<b>STRENGTH AND SECURING OF SMALL HATCHES, FITTINGS AND EQUIPMENT ON THE FORE DECK .....</b>	<b>127</b>
Section 1	Application and Implementation .....	127
Section 2	Strength and Securing of Small Hatches on the Exposed Fore Deck .....	127
Section 3	Strength Requirements for Fore Deck Fittings and Equipment .....	130
<b>CHAPTER 10</b>	<b>SHIPBOARD EQUIPMENT, FITTINGS AND SUPPORTING HULL STRUCTURES ASSOCIATED WITH TOWING AND MOORING .....</b>	<b>135</b>
Section 1	Definitions and Scope of Application .....	135
Section 2	Towing and Mooring .....	136
<b>CHAPTER 11</b>	<b>ACCESS TO AND WITHIN SPACES IN, AND FORWARD OF, THE CARGO AREA OF OIL TANKERS AND BULK CARRIERS .....</b>	<b>143</b>
Section 1	General .....	143
Section 2	Technical Provisions for Means of Access for Inspections .....	144

# CHAPTER 1 RUDDERS

## Section 1 General

### 101. Application [See Guidance]

1. The requirements in this Chapter apply to single plate rudders of stream line section and ordinary shape and to some enhanced profile rudder with special arrangements for increasing the rudder force, being divided into the following types ;
  - (1) Type A : Rudders with upper and bottom pintles. (See Fig 4.1.1 Type A)
  - (2) Type B : Rudders with the neck bearing and the bottom pintle. (See Fig 4.1.1 Type B)
  - (3) Type C : Rudders having no bearing below the neck bearing. (See Fig 4.1.1 Type C)
  - (4) Type D : Mariner type rudders with neck bearing and pintle, of which lower end is fixed. (See Fig 4.1.1 Type D)
  - (5) Type E : Mariner type rudders with two pintles, of which lower ends are fixed. (See Fig 4.1.1 Type E)
2. This chapter applies to rudders made of steel.
3. The construction of rudders with three or more pintles and of nozzle rudder are to be in accordance with the discretion of the Society.
4. The construction of rudders designed to move more than 35 degrees on one side is to be in accordance with the discretion of the Society.

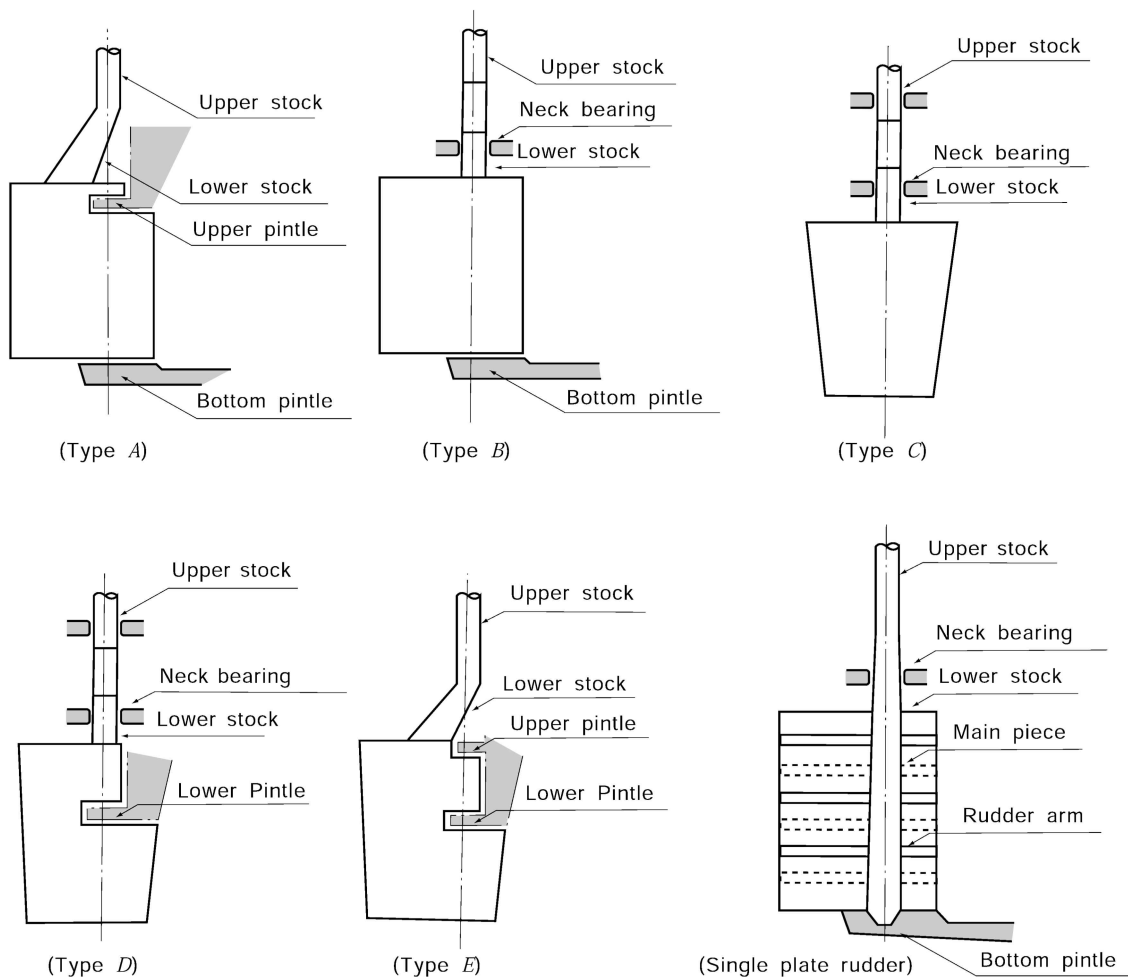


Fig 4.1.1 Types of rudders

### 102. Design considerations

Effective means are to be provided for supporting the weight of the rudder without excessive bearing pressure, e.g. by a rudder carrier attached to the upper part of the rudder stock. The hull structure in way of the rudder carrier is to be suitably strengthened.

### 103. Materials [See Guidance]

1. Rudders stocks, pintles, coupling bolts, keys and cast parts of rudders are to be made of rolled steel, steel forging or carbon steel casting conforming to the requirements in **Pt 2, Ch 1** of the Rules. For rudder stocks, pintles, coupling bolts and keys, the minimum yield stress is not to be less than 200 (N/mm<sup>2</sup>). The requirements in this Chapter are based on a material's yield stress of 235 (N/mm<sup>2</sup>). If material is used having a yield stress differing from 235 (N/mm<sup>2</sup>) the material factor *K* is to be determined by **Table 4.1.1**.
2. The parts of rudders are to be made of approved rolled hull materials in accordance with **Pt 2, Ch 1** of the Rules. The material factor *K* it to be taken as defined in **Table 4.1.2**.
3. Steel grade of plating materials for rudders and rudder horns are to be in accordance with **Pt 3, Ch 1, 405.** of the Rules.

**Table 4.1.1 Material factor *K* (for steel forging and carbon steel casting)**

$\sigma_y$ (N/mm <sup>2</sup> )	<i>K</i>
$\sigma_y > 235$	$K = \left( \frac{235}{\sigma_y} \right)^{0.75}$
$\sigma_y \leq 235$	$K = \left( \frac{235}{\sigma_y} \right)^{1.0}$
$\sigma_y$ = yield stress(N/mm <sup>2</sup> ) of material used, and is not to be taken greater than 0.7 $\sigma_T$ or 450(N/mm <sup>2</sup> ), whichever is smaller value. $\sigma_T$ = minimum tensile strength of material used (N/mm <sup>2</sup> ).	

**Table 4.1.2 Material factor *K* (for rolled steel)**

Material	<i>K</i>
<i>A, B, D</i> or <i>E</i>	1.0
<i>AH 32, DH 32</i> or <i>EH 32</i>	0.78
<i>AH 36, DH 36</i> or <i>EH 36</i>	0.72
<i>AH 40, DH 40</i> or <i>EH 40</i>	0.68

### 104. Increase in diameter of rudder stocks for special cases

1. The diameters of rudder stocks for ships exclusively engaged in towing services are not to be less than 1.1 times those required in this Chapter.
2. In ships which may be frequently steered at a large helm angle when sailing at their maximum speed, such as fishing vessels, the diameters of rudder stocks and pintles, as well as the section modulus of main pieces, are not to be less than 1.1 *times* those required in this Chapter.
3. In ships which might require quick steering, the diameters of rudder stocks are to be properly increased beyond the requirements in this Chapter.
4. The rudders for ships classified for navigation in ice are to be in accordance with the requirements of **the Guidance for Ships for Navigation In Ice** in addition to the requirements of this Chapter.

### 105. Sleeves and bushes

Bearings located from the bottom of rudder to well above the load line are to be provided with sleeves and bushes.

### 106. Welding

1. Slot-welding is to be limited as far as possible. Slot welding is not to be used in areas with large in-plane stresses transversely to the slots or in way of cut-out areas of Type *A*, Type *D* and Type *E* rudders.
2. When slot welding is applied, the length of slots is to be minimum 75 mm with breadth of 2 times of the rudder plate thickness. The distance between ends of slots is not to be more than 125 mm. The slots are to be fillet welded around the edges and filled with a suitable compound, e.g. epoxy putty.
3. Continuous slot welds are to be used in lieu of slot welds. When continuous slot welding is applied, the root gap is to be between 6-10 mm. The bevel angle is to be at least 15°.
4. In way of the rudder horn recess of Type *A*, Type *D* and Type *E* rudders the radii in the rudder plating are not to be less than 5 times the plate thickness, but in no case less than 100 mm. Welding in side plate are to be avoided in or at the end of the radii. Edges of side plate and weld adjacent to radii are to be ground smooth.
5. Welds between plates and heavy pieces (solid parts in forged or cast steel or very thick plating) are to be made as full penetration welds. In way of highly stressed areas e.g. cut-out of semi-spade rudder and upper part of spade rudder, cast or welding on ribs is to be arranged. Two sided full penetration welding is normally to be arranged. Where back welding is impossible welding is to be performed against ceramic backing bars or equivalent. Steel backing bars may be used and are to be continuously welded on one side to the heavy piece.

### 107. Equivalence

1. This Society may accept alternatives to requirements given in this Chapter provided they are deemed to be equivalent according to **Pt 1, 104.** or **105.** of the Guidance.
2. Direct analyses adopted to justify an alternative design are to take into consideration all relevant modes of failure, on a case by case basis. These failure modes may include, amongst others: yielding, fatigue, buckling and fracture. Possible damages caused by cavitation are also to be considered.
3. If deemed necessary by this Society, lab tests, or full scale tests may be requested to validate the alternative design approach.

## Section 2 Rudder Force

### 201. Rudder force

The rudder force  $F_R$  upon which the rudder scantlings are to be based is to be obtained from the following formula, for each of going ahead or astern. However, when the rudder is arranged behind the propeller that produces an especially great thrust, the rudder force is to be appropriately increased.

$$F_R = 132K_1K_2K_3AV^2 \quad (\text{N})$$

where :

$A$  = area of rudder plate ( $\text{m}^2$ ).

$V$  = speed of ship(Kt) as defined in **Pt 3, Ch 1** of the Rules. When the speed is less than 10 knots,  $V$  is to be replaced by  $V_{\min}$  obtained from the following formula ;

$$V_{\min} = \frac{V+20}{3} \quad (\text{Kt})$$

For the astern condition, the astern speed  $V_a$  is to be obtained from the following formula. However, when the maximum astern speed is designed to exceed  $V_a$  the design maximum astern speed is to be used.

$$V_a = 0.5 V \quad (\text{Kt})$$

$K_1$  = factor depending on the aspect ratio  $\Lambda$  of the rudder area, obtained from the following formula.

$$K_1 = \frac{\Lambda+2}{3}$$

$\Lambda$  = as obtained from the following formula. However,  $\Lambda$  is not required to be greater than 2.

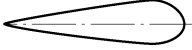

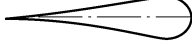



$$\Lambda = \frac{h^2}{A_t}$$

$h$  = mean height of rudder (m), which is determined according to the coordinate system in **Fig 4.1.2**.

$A_t$  = sum of rudder plate area  $A$  (m<sup>2</sup>) and area of rudder post or rudder horn, if any, within the mean height of rudder  $h$ .

$K_2$  = factor depending on the rudder profile (See **Table 4.1.3**).

Table 4.1.3 Factor  $K_2$

Profile type	$K_2$	
	Ahead condition	Astern condition
NACA-00 Göttingen profiles 	1.1	0.80
Hollow profiles 	1.35	0.90
Flat side profiles 	1.1	0.90
High lift rudder 	1.70	to be specially considered; if not known: 1.30
Fish tail 	1.40	0.80
Single plate 	1.00	1.00
Mixed profiles(e.g. HSVA)	1.21	0.90

$K_3$  = factor depending on the location of rudder (See Table 4.1.4).

Table 4.1.4 Factor  $K_3$

Location of rudder	$K_3$
for rudders outside the propeller jet	0.8
for rudders behind a fixed propeller nozzle	1.15
otherwise	1.0

### Section 3 Rudder Torque

#### 301. Rudder torque of Type B and Type C rudders (Rudder without cut-outs)

The rudder torque  $T_R$  of Type B and C rudders is to be obtained for ahead and astern conditions, respectively, according to the following formula.

$$T_R = F_R \times r \quad (\text{N-m})$$

where :

$F_R$  = as specified in 201.

$r$  = distance from the centre of rudder force on the rudder to the centreline of the rudder

stock, determined by the following formula.

$$r = b(\alpha - e) \quad (\text{m})$$

For the ahead condition, however,  $r$  is not to be less than  $r_{\min}$  obtained from the following formula.

$$r_{\min} = 0.1b \quad (\text{m})$$

$b$  = mean breadth(m) of rudder determined by the coordinate system in **Fig 4.1.2**.

$\alpha$  = to be as **Table 4.1.5**.

**Table 4.1.5 Factor  $\alpha$**

Course of rudder	$\alpha$
Ahead condition	0.33
Astern condition	0.66

$e$  = balance factor of the rudder obtained from the following formula.

$$e = \frac{A_f}{A}$$

$A_f$  = portion of the rudder plate area situated ahead of the centerline of the rudder stock (m<sup>2</sup>).

$A$  = as specified in **201**.

### 302. Rudder torque of Type *A*, *D* and *E* rudders (Rudder with stepped contours)

1. The rudder torque  $T_R$  of Type *A*, *D* and *E* rudders is to be obtained for the ahead and astern conditions, respectively, according to the following formula :

$$T_R = T_{R1} + T_{R2} \quad (\text{N-m})$$

where :

$T_{R1}$  and  $T_{R2}$  = rudder torque(N-m) of portion of  $A_1$  and  $A_2$ , respectively, obtained from the following formulae, respectively.

$$T_{R1} = F_{R1} \times r_1 \quad (\text{N-m})$$

$$T_{R2} = F_{R2} \times r_2 \quad (\text{N-m})$$

$A_1$  and  $A_2$  = areas of respective rectangles (m<sup>2</sup>) determined by dividing the rudder area into two parts so that  $A = A_1 + A_2$  ( $A_1$  and  $A_2$  include  $A_{1f}$  and  $A_{2f}$  respectively), as specified in

**Fig 4.1.3**.

$F_R$  and  $A$  = as specified in **201**.

$F_{R1}$  and  $F_{R2}$  = the rudder force of portions  $A_1$  and  $A_2$ , obtained from the following formulae, respectively.

$$F_{R1} = F_R \frac{A_1}{A} \quad (\text{N})$$

$$F_{R2} = F_R \frac{A_2}{A} \quad (\text{N})$$

$r_1$  and  $r_2$  = the distances from each centre of rudder force of portions  $A_1$  and  $A_2$  to the centre-line of the rudder stock, determined by the following formulae, respectively.

$$r_1 = b_1(\alpha - e_1) \quad (\text{m})$$

$$r_2 = b_2(\alpha - e_2) \quad (\text{m})$$

$e_1$  and  $e_2$  = the balance factors of portions  $A_1$  and  $A_2$ , obtained from the following formulae, respectively.

$$e_1 = \frac{A_{1f}}{A_1}, \quad e_2 = \frac{A_{2f}}{A_2}$$

$\alpha$  = to be as **Table 4.1.6**.

**Table 4.1.6 Factor  $\alpha$**

Locations of rudder parts		$\alpha$
For parts of a rudder not behind a fixed structure such as rudder horn	for ahead condition	0.33
	for astern condition	0.66
For parts of a rudder behind a fixed structure such as rudder horn	for ahead condition	0.25
	for astern condition	0.55

**2.** For the ahead condition, however,  $T_R$  is not to be less than  $T_{R\min}$  obtained from the following formula :

$$T_{R\min} = 0.1 F_R \frac{A_1 b_1 + A_2 b_2}{A} \quad (\text{N-m})$$

$F_R$  and  $A$  = as specified in **201**.

$b_1$  and  $b_2$  = mean breadth (m) of portions  $A_1$  and  $A_2$ , determined by applying **Fig 4.1.2** correspondingly.

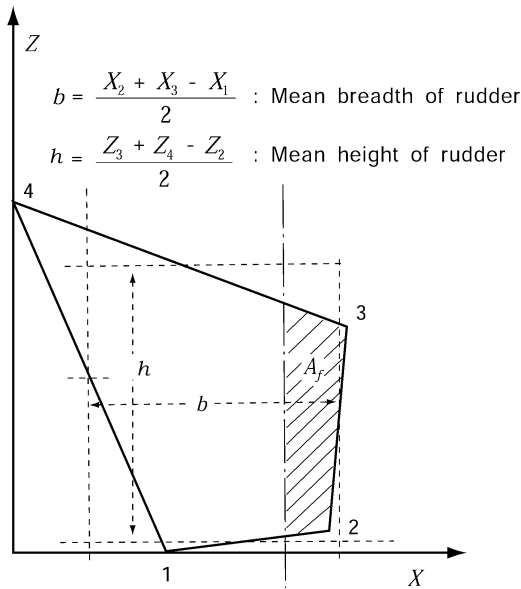


Fig 4.1.2 Coordinate system of rudders

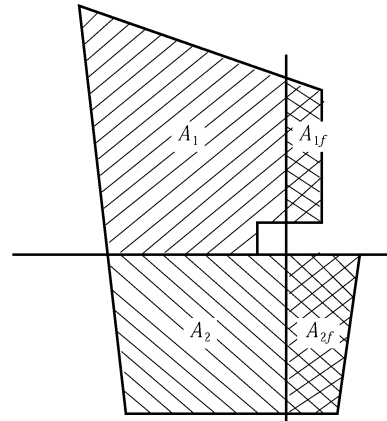


Fig 4.1.3 Division of rudder area

## Section 4 Rudder Strength Calculation

### 401. Rudder strength calculation

1. The rudder strength is to be sufficient against the rudder force and rudder torque as given in **Sec 2** and **Sec 3**. When the scantling of each part of a rudder is determined, the following moments and forces are to be considered.

For rudder body : bending moment and shear force

For rudder stock : bending moment and torque

For pintle bearing and rudder stock bearing : supporting force

For rudder horn and heel pieces : bending moment, shear force and torque

2. The bending moments, shear forces and supporting forces to be considered are to be determined by a direct calculation or an approximate simplified method as deemed appropriate by the Society. For rudders supported by sole pieces or rudder horns these structures are to be included in the calculation model in order to account for the elastic support of the rudder body. Guidelines for calculation of bending moment and shear force distribution are to be in accordance with the Guidance relating to the Rules specified by the Society. **[See Guidance]**

## Section 5 Rudder Stocks

### 501. Upper stocks **[See Guidance]**

The upper stock diameter  $d_u$  required for the transmission of the rudder torque is to be determined so that the torsional stress not exceed  $68/\text{Kg}(\text{N}/\text{mm}^2)$ . In dimensioning, the upper stock diameter may be determined by the following formula:

$$d_u = 4.2 \sqrt[3]{T_R K_S} \quad (\text{mm})$$

$T_R$  = as specified in **301.** and **302.**

$K_S$  = material factor for rudder stock, as given in **103.**

### 502. Lower stocks

If the lower stock is subjected to combined torque and bending, the equivalent stress in the lower stock is not to exceed  $118 / K_s$  (N/mm<sup>2</sup>). The equivalent stress  $\sigma_e$  is to be obtained from the following formula :

$$\sigma_e = \sqrt{\sigma_b^2 + 3\tau_t^2} \quad (\text{N/mm}^2)$$

where :

$\sigma_b$  and  $\tau_t$  = the bending stress and torsional stress acting on the lower stock, determined as follows respectively :

$$\sigma_b = \frac{10.2M}{d_l^3} \times 10^3 \quad (\text{N/mm}^2)$$

$$\tau_t = \frac{5.1T_R}{d_l^3} \times 10^3 \quad (\text{N/mm}^2)$$

$M$  = bending moment(N-m) at the section of the rudder stock considered.

$T_R$  = as specified in **301.** and **302.**

$d_l$  = lower stock diameter(mm), when the horizontal section of the lower stock forms a circle,

$d_l$  may be determined by the following formula :

$$d_l = d_u \sqrt[6]{1 + \frac{4}{3} \left( \frac{M}{T_R} \right)^2} \quad (\text{mm})$$

where :

$d_u$  = upper stock diameter(mm) as given in **501.**

## Section 6 Rudder Plates, Rudder Frames and Rudder Main Pieces

### 601. Rudder plate

The rudder plate thickness  $t$  is not to be less than that obtained from the following formula :

$$t = 5.5S\beta \sqrt{\left( d + \frac{F_R \times 10^{-4}}{A} \right) K_{pl} + 2.5} \quad (\text{mm})$$

where :

$A$  and  $F_R$  = as specified in **201.**

$K_{pl}$  = material factor for the rudder plate as given in **103.**

$d$  = as specified in **Pt 3, Ch 1, 111.** of the Rule.

$\beta$  = to be obtained from the following formula :

$$\beta = \sqrt{1.1 - 0.5 \left( \frac{S}{a} \right)^2} \quad \text{max : } 1.0, \text{ if } \left( \frac{a}{S} \geq 2.5 \right)$$

$S$  = spacing of horizontal or vertical rudder frames, whichever is smaller (m).

$a$  = spacing of horizontal or vertical rudder frames, whichever is greater (m).

### 602. Rudder frames

1. The rudder body is to be stiffened by horizontal and vertical rudder frames enabling it to act as bending girder.
2. The standard spacing of horizontal rudder frames,  $S_f$  is to be obtained from the following formula :

$$S_f = 0.2 \left( \frac{L}{100} \right) + 0.4 \quad (\text{m})$$

3. The standard distance from the vertical rudder frame forming the rudder main piece to the adjacent vertical rudder frame is to be 1.5 *times* the spacing of horizontal rudder frames.
4. The thickness of rudder frames is not to be less than 8 mm or 70 % of the thickness of the rudder plates as given in **601**. whichever is greater.

### 603. Rudder main pieces [See Guidance]

1. Vertical rudder frames forming the rudder main piece are to be arranged forward and afterward of the centerline of rudder stock at a distance approximately equal to the thickness of the rudder where the main piece consists of two rudder frames, or at the centerline of the rudder stock where the main piece consists of one rudder frame.
2. The section modulus of the main piece is to be calculated in conjunction with the vertical rudder frames specified in **Par 1** and rudder plates attached thereto. The effective breadth of the rudder plates normally taken into calculation are to be as follows :
  - (1) Where the main piece consists of two rudder frames, the effective breadth is 0.2 *times* the length of the main piece.
  - (2) Where the main piece consists of one rudder frame, the effective breadth is 0.16 *times* the length of the main piece.

3. In general, except in way of rudder recess sections where 4. applies, the section modulus and the web area of a horizontal section of the main piece are to be such that bending stress, shear stress and equivalent stress will be accordance with the following stress values, respectively. (2019)

$$\sigma_b \leq \frac{110}{K} \quad (\text{N/mm}^2), \quad \tau \leq \frac{50}{K} \quad (\text{N/mm}^2),$$

$$\sigma_e = \sqrt{\sigma_b^2 + 3\tau^2} \leq \frac{120}{K} \quad (\text{N/mm}^2)$$

where :

$K_m$  = material factor for the rudder main piece as given in **103**.

4. In the cases of Type *A*, *D*, and *E* rudders, the section modulus and the web area of a horizontal section of the main piece in way of cut-outs are to be such that bending stress, shear stress and equivalent stress not exceed the following stress values, respectively. (2019)

$$\sigma_b \leq 75 \quad (\text{N/mm}^2), \quad \tau \leq 50 \quad (\text{N/mm}^2),$$

$$\sigma_e = \sqrt{\sigma_b^2 + 3\tau^2} \leq 100 \quad (\text{N/mm}^2)$$

5. The upper part of the main piece is to be so constructed as to avoid structural discontinuity.
6. Maintenance openings and cut-outs of rudder plates in Type *A*, *D*, and *E* rudders are to be rounded off properly.

#### 604. Rudder plates, rudder arms and rudder main pieces of single plate rudders

1. The rudder plate thickness  $t$  is not to be less than that obtained from the following formula :

$$t = 1.5SV\sqrt{K_{pl}} + 2.5 \quad (\text{mm})$$

where :

$S$  = spacing (m) of rudder arms, not to exceed 1 m.

$V$  = speed of ship (Kt) as specified in **201**.

$K_{pl}$  = material factor for rudder plate as given in **103**.

2. Rudder arms are to comply with the following requirements.

- (1) The thickness of rudder arms is not to be less than that of rudder plates.
- (2) The section modulus of rudder arms is not to be less than the value obtained from the following formula. This section modulus, however, may be reduced gradually toward the edge of the rudder plate.

$$Z = 0.5SC_1^2V^2K_a \quad (\text{cm}^3)$$

where :

$C_1$  = horizontal distance (m) from the aft edge of the rudder plate to the centre of the rudder stock.

$K_a$  = material factor for the rudder arm as given in **103**.

$S$  and  $V$  = as specified in **Par 1**.

3. The diameters of main pieces are not to be less than those of lower rudder stocks. In rudders having no bearing below the neck bearing, however, the main piece diameter may be reduced gradually within the lower 1/3 area of the rudder, and may be 75 % of the specified diameter at the bottom part.

#### 605. Connections [See Guidance]

1. Gudgeon in forged or cast steel, which house the rudder stock or the pintle, are to be provided with protrusions, except where not required as indicated below. (2019)

These protrusions are not required when the web plate thickness is less than :

- (1) 10 mm for web plates welded to the gudgeon on which the lower pintle of a semi-spade rudder is housed and for vertical web plates welded to the gudgeon of the rudder stock coupling of spade rudders.
- (2) 20 mm for other web plates.

2. The gudgeon are in general to be connected to the rudder structure by means of two horizontal web plates and two vertical web plates.

3. connection with the rudder stock housing

- (1) The section modulus of the cross-section of the structure of the rudder blade ( $\text{cm}^3$ ), formed by vertical web plates and rudder plating, which is connected with gudgeon is to be not less than:

$$Z = c_s d^3 \left( \frac{h_E - h_X}{h_E} \right)^2 \frac{K}{K_s} 10^{-4} \quad (\text{cm}^3)$$

$c_s$  = coefficient, to be taken equal to :

= 1.0, if there is no opening in the rudder plating or if such openings are closed by a full penetration welded plate

- $= 1.5$ , if there is an opening in the considered cross-section of the rudder
- $d$  = rudder stock diameter (mm)
- $h_E$  = vertical distance between the lower edge of the rudder blade and the upper edge of the gudgeon (m)
- $h_X$  = vertical distance between the considered cross-section and the upper edge of the gudgeon (m)
- $K$  = material factor for the rudder blade plating as given in **103**.
- $K_s$  = material factor for the rudder stock as given in **103**.
- (2) The breadth of the rudder plating, in m, to be considered for the calculation of section modulus is to be not greater than:

$$b = S + \frac{2h_X}{3} \quad (m)$$

$S$  = spacing between the two vertical webs (m)

$h_X$  = according to (1)

- (3) Where openings for access to the rudder stock nut are not closed by a full penetration welded plate, they are to be deducted.

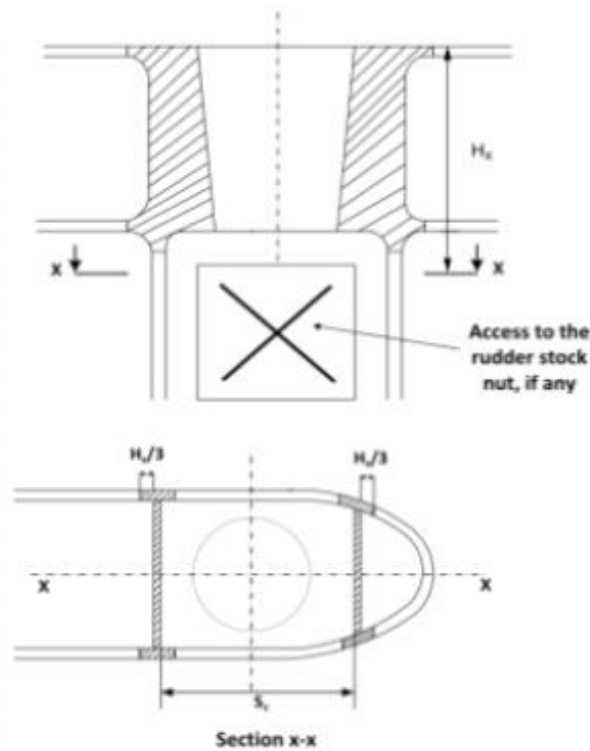


Fig 4.1.4 Connection between rudder structure and rudder stock gudgeon

4. The thickness of the horizontal web plates connected to the gudgeon, in mm, as well as that of the rudder blade plating between these webs, is to be not less than the greater of the following values:

$$t_H = 1.2t \quad (mm)$$

$$t_H = 0.045 \frac{d_s^2}{S_H} \quad (mm)$$

$t$  = thickness of rudder plate as defined in **Par 601**.

$d_s$  = diameter of rudder stock or pintle

$S_H$  = spacing between the two horizontal web plates (mm)

- The thickness of the vertical web plates welded to the gudgeon as well as the thickness of the rudder side plating under this gudgeon is to be not less than the values obtained from **Table 4.1.7**.

**Table 4.1.7 Thickness of rudder plating and vertical web plates**

Type of rudder	Thickness of vertical web plates (mm)		Thickness of rudder plating (mm)	
	Rudder blade without opening	Rudder blade with opening	Rudder blade without opening	Area with opening
Rudder supported by sole piece	1.2 t	1.6 t	1.2 t	1.4 t
Semi-spade and spade rudders	1.4 t	2.0 t	1.3 t	1.6 t

(Remark)  
 (1)  $t$  = thickness of the rudder plating (mm) as defined in **Par 601**.  
 (2) The increased thickness is to extend below the gudgeon at least to the next horizontal web.

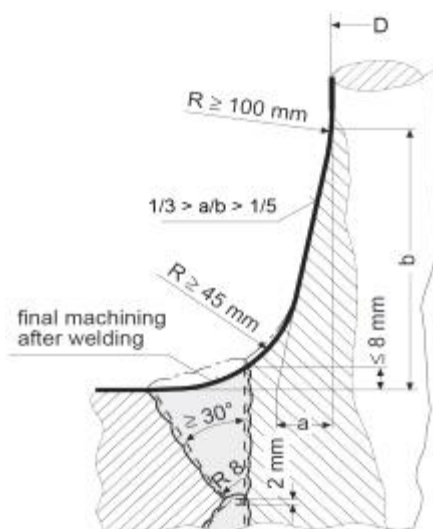
### 606. Paintings and drainings

The internal surface of rudder is to be coated with effective paint, and means for draining are to be provided at the bottom of rudder.

## Section 7 Couplings between Rudder Stocks and Main Pieces

### 701. Horizontal flange couplings [See Guidance]

- Coupling bolts are to be reamer bolts and at least 6 reamer bolts are to be used in each coupling.
- Couplings are to comply with the requirements in **Table 4.1.7**.
- The welded joint between the rudder stock and the flange is to be made in accordance with **Figure 4.1.5** or equivalent.



**Fig 4.1.5** Welded joint between rudder stock and coupling flange

**702. Vertical flange couplings [See Guidance]**

1. Coupling bolts are to be reamer bolts and at least 8 reamer bolts are to be used in each coupling.
2. Couplings are to comply with the requirements in **Table 4.1.8**.

**Table 4.1.8 The minimum requirements for rudder couplings to stock**

Parameter	Requirement	
	Horizontal flange coupling	Vertical flange coupling
$d_b$	$0.62 \sqrt{\frac{d^3 K_b}{n e_m K_s}}$	$\frac{0.81d}{\sqrt{n}} \times \sqrt{\frac{K_b}{K_s}}$
$M$	-	$0.00043 d_v^3$
$t_f$	$d_b \sqrt{\frac{K_f}{K_b}}$ (not less than $0.9d_b$ ) <sup>(1)</sup>	$d_b$
$w_f$	$0.67d_b$	$0.67d_b$
<p><math>n</math> = total number of bolts.  <math>d_b</math> = bolt diameter (mm).  <math>d</math> = stock diameter (mm), the greater of the diameters <math>d_u</math> or <math>d_l</math> according to <b>501</b>. and <b>502</b>.  <math>d_v</math> = stock diameter in way of coupling flange  <math>M</math> = the first moment of area of the bolts about the centerline of the coupling flange (cm<sup>3</sup>)  <math>e_m</math> = mean distance (mm) of the bolt axes from the centre of the bolt system.  <math>K_s</math> = material factor for the rudder stock as given in <b>103</b>.  <math>K_b</math> = material factor for the bolts as given in <b>103</b>.  <math>K_f</math> = material factor for the coupling flange as given in <b>103</b>.  <math>t_f</math> = the thickness (mm) of the coupling flanges.  <math>w_f</math> = the width (mm) of the material outside the bolt holes of the coupling flanges.</p>		
<p>NOTE :</p> <p>(1) Where a number of bolts exceeding 8, the thickness of coupling flange, <math>t_f</math> is to be calculated from <math>d_b</math> determined by a number of bolts equal to 8.</p>		

**703. Cone couplings [See Guidance]**

1. Cone couplings without hydraulic arrangements (oil injection and hydraulic nut, etc.) for mounting and dismantling the coupling are to comply with the following requirements.

- (1) The couplings are to have a taper  $c$  on diameters of 1 : 8 ~ 1 : 12 and be secured by the slugging nut. (See **Fig 4.1.6**)

$$c = \frac{d_0 - d_u}{l}$$

$d_0$  = actual diameter (mm) of rudder stock (See **Fig 4.1.6**)

$d_u$  = according to **Fig 4.1.6**

$l$  = length of coupling (mm)

- (2) The cone shapes are to fit exactly. The coupling length  $l$  is to be, in generally, not to be less than 1.5 times the rudder stock diameter  $d_0$  at the top of the rudder.
- (3) For the couplings between stock and rudder, a key is to be provided. And the scantling of the key is to be accordance with as follows.
  - (A) The shear area of a key is not to be less than :

$$A_k = \frac{17.55 M_F}{d_k \sigma_{k1}} \quad (\text{cm}^2)$$

$M_F$  = design torsional moment of rudder stock (Nm)

$$M_F = 0.02664 \frac{d_u^3}{K_s}$$

$d_u$  = diameter of upper rudder stock as defined in 501. Where the actual diameter  $d_0$  is greater than the calculated diameter  $d_u$  is to be used. However the value need not be taken greater than  $1.145d_u$ .

$K_s$  = material factor for the rudder stock as given in 103.

$d_k$  = mean diameter (mm) of the conical part of the rudder stock at the key

$\sigma_{k1}$  = minimum yield stress of the key material (N/mm<sup>2</sup>)

- (4) The dimensions of the slugging nut as specified in the preceding (1) are to be as follows (See Fig 4.1.6) :

$$d_g \geq 0.65d_0 \quad (\text{mm})$$

$$h_n \geq 0.6d_g \quad (\text{mm})$$

$$d_n \geq 1.2d_u \text{ or } 1.5d_g \quad (\text{mm}), \text{ whichever is greater.}$$

where :

$d_g$  = actual external thread diameter(mm).

$h_n$  = length of nut(mm).

$d_n$  = outer diameter of nut(mm).

- (5) The nuts fixing the rudder stocks are to be provided with efficient locking devices such securing plate or flat bar etc.  
 (6) Couplings of rudder stocks are to be properly protected from corrosion.  
 (7) It is to be proved that 50% of the design yield moment is solely transmitted by friction in the cone couplings. This can be done by calculating the required push-up force and push-up length according to Par 2 (5) for a torsional moment of (3)  $M_F=0.5M_F$ .  
 (8) Notwithstanding the requirements in (7) where the entire rudder torque is transmitted by the key at the couplings, the scantlings of the key as well as the push-up force and push-up length are to be at the discretion of the Society.

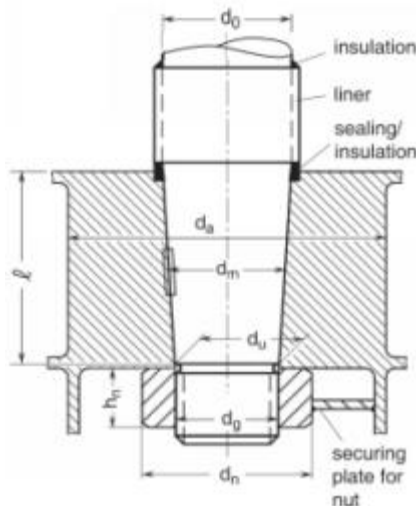


Fig 4.1.6 Cone coupling with key

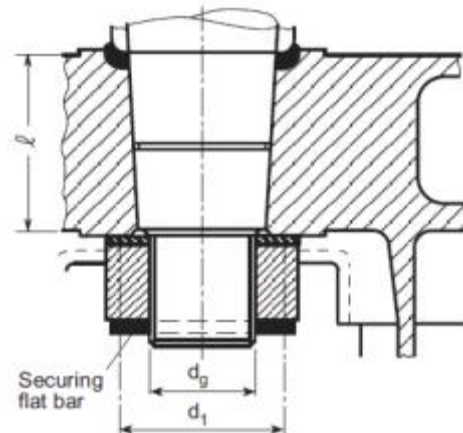


Fig 4.1.7 Cone coupling without key

2. Cone couplings with hydraulic arrangements (oil injection and hydraulic nut, etc.) for mounting and dismantling the coupling are to comply with the following requirements.
- (1) Where the stock diameter exceeds 200 mm, the press fit is recommended to be effected by a hydraulic pressure connection. In such cases the cone is to be more slender, c 1 : 12 ~ 1 : 20.
  - (2) The nuts fixing the rudder stocks are to be provided with efficient locking devices. However, a securing plate for securing nut against the rudder body is not to be provided.
  - (3) Couplings of rudder stocks are to be properly protected from corrosion.
  - (4) The dimensions of the securing nuts are to be as specified **Par 1** (4).
  - (5) For the safe transmission of the torsional moment by the coupling between rudder stock and rudder body the push-up force and the push-up length are to be determined according to (6) ~ (8).
  - (6) The push-up pressure is not to be less than the greater of the two following values: (2019)

$$P = \frac{2M_F}{d_m^2 \ell \pi \mu_0} 10^3 \quad (N/mm^2) \quad \text{or} \quad P = \frac{6M_b}{\ell^2 d_m} 10^3 \quad (N/mm^2)$$

$M_F$  = design torsional moment (Nm) of rudder stock, as defined in **Par 1** (3)

$d_m$  = mean cone diameter (mm) (See **Fig 4.1.6**)

$\ell$  = cone length (mm)

$\mu_0$  = frictional coefficient, equal to 0.15

$M_b$  = bending moment in the cone coupling (e.g. in case of Type *C*, *D* and *E* rudders) (mm)

It has to be proved by the designer that the push-up pressure does not exceed the permissible surface pressure in the cone. The permissible surface pressure  $P_{perm}$  (N/mm<sup>2</sup>), is to be determined by the following formula:

$$P_{perm} = \frac{0.95 R_{cH} (1 - \alpha^2)}{\sqrt{3 + \alpha^4}} - P_b \quad (N/mm^2)$$

$$P_b = \frac{3.5 M_b}{d_m l^2} 10^3$$

$R_{cH}$  = minimum yield stress of the material of the gudgeon (N/mm<sup>2</sup>)

$\alpha$  =  $d_m/d_a$

$d_a$  = outer diameter of the gudgeon (See **Fig 4.1.6**)

The outer diameter of the gudgeon in mm shall not be less than 1.25  $d_0$ , with  $d_0$  defined in **Fig 4.1.6**.

- (7) The push-up length  $l$  is to be accordance with as following. (2019)

$$l_1 \leq l \leq l_2 \quad (mm)$$

$$l_1 = \frac{P d_m}{E \left( \frac{1 - \alpha^2}{2} \right) c} + \frac{0.8 R_{tm}}{c} \quad (mm)$$

$$l_2 = \frac{P_{perm} d_m}{E \left( \frac{1 - \alpha^2}{2} \right) c} + \frac{0.8 R_{tm}}{c} \quad (mm)$$

$P$  = push-up pressure as defined in (6)

$P_{perm}$  = permissible surface pressure as defined in (6)

$d_m$  = mean cone diameter (mm) (See **Fig 4.1.6**)

- $R_{tm}$  = mean roughness taken equal to 0.01  
 $E$  =  $2.06 \times 10^5$  (N/mm<sup>2</sup>)  
 $c$  = taper on diameter (mm) according to (1)  
 $\alpha$  = according to (6)

(8) The push-up force for the cone to be obtained from the following formula.

$$F = Pd_m \pi \ell \left( \frac{c}{2} + \mu_0 \right) \quad (N)$$

- $P$ ,  $d_m$ ,  $\ell$  = according to (6)  
 $c$  = taper on diameter (mm) according to (1)  
 $\mu_0$  = friction coefficient using oil pressure, the value 0.02 is a reference. It varies and depends on the mechanical treatment and roughness of the details to be fixed.

## Section 8 Pintles

### 801. Diameters of pintles

The diameters of pintles  $d_p$  are not to be less than the dimension obtained from the following formula.

$$d_p = 0.35 \sqrt{BK_p} \quad (\text{mm})$$

where :

- $B$  = reaction force in bearing (N)  
 $K_p$  = material factor for pintles as given in **103**.

### 802. Construction of pintles [See Guidance]

1. Pintles constructed as taper bolts are to have a taper on the diameter not exceeding the following values, and capable of being fitted to the gudgeons. The nuts fixing the pintles are to be provided with efficient locking devices.
  - (1) For keyed pintles to be assembled and locked with slugging nuts : 1 : 8 ~ 1 : 12
  - (2) For pintles mounted with hydraulic arrangements (oil injection and hydraulic nut, etc.) : 1 : 12 ~ 1 : 20
2. The minimum dimensions of the threads and the nuts of pintles are to be determined by applying the requirements in **703. 1. (4)** correspondingly.
3. The length of the pintle housing in the gudgeon is not to be less than the pintle diameter  $d_p$ . The  $d_p$  is to be measured on the outside of liners. The thickness of the pintle housing is not to be less than  $0.25d_p$ .
4. Pintles are to be properly protected from corrosion.
5. The required push-up pressure for pintle (N/mm<sup>2</sup>), is to be determined by the following formula. The push up length is to be calculated similarly as in **703. 2 (7)**, using required push-up pressure and properties for the pintle. (2019)

$$P = 0.4 \frac{Bd_p}{d_m^2 \ell} \quad (N/mm^2)$$

$B$  = Supporting force in the pintle (N)

$d_m, \ell$  = according to 703. 2 (6)

### Section 9 Bearings of Rudder Stocks and Pintles

#### 901. Minimum bearing surface [See Guidance]

The bearing surface  $A_b$  (defined as the projected area : *Bearing length* × *outside diameter of sleeve*) is not to be less than the value obtained from the following formula.

$$A_b = \frac{B}{q_a} \quad (\text{mm}^2)$$

where :

$B$  = as specified in 801.

$q_a$  = allowable surface pressure(N/mm<sup>2</sup>). The allowable surface pressure for the various bearing combination is to be taken from **Table 4.1.9**. When verified by tests, however, different values from those in this Table may be taken.

**Table 4.1.9 Allowable surface pressure  $q_a$**

Bearing material	$q_a$ (N/mm <sup>2</sup> )
Lignum vitae	2.5
White metal (oil-lubricated)	4.5
Synthetic materials with hardness between 60 and 70, Shore D <sup>(1)(2)</sup>	5.5
Steel <sup>(3)</sup> , bronze and hotpressed bronze-graphite materials	7.0

NOTES :

<sup>(1)</sup> Indentation hardness test at the temperature of 23°C and humidity of 50 %, according to a recognized standard. Synthetic bearings are to be of approved type.

<sup>(2)</sup> Surface pressures exceeding 5.5 N/mm<sup>2</sup> may be accepted in accordance with bearing manufacturer's specification and tests, but in no case more than 10 N/mm<sup>2</sup>.

<sup>(3)</sup> Stainless and wear-resistant steel in an approved combination with a stock liner.

#### 902. Length of bearings

The length of the bearing is to be accordance with the following.

$$d_{sl} \leq h_b \leq 1.2d_{sl}$$

$d_{sl}$  = Actual pintle diameter measured on the outside of rudder stock or liners.

#### 903. Bearing clearances [See Guidance]

With metal bearings clearances are not to be less than  $d_{bs}/1000+1.0$  (mm) on the diameter.

where :

$d_{bs}$  = the internal diameter of bush (mm).

If non-metallic bearing material is applied, the bearing clearance is to be specially determined considering the material's swelling and thermal expansion properties. This clearance not is to be taken less than 1.5 mm on bearing diameter, unless a smaller clearance is supported by the manufacture's recommendation and there is documented evidence of satisfactory service history with a reduced clearance.

#### 904. Thickness of bush and sleeve

The thickness of any bush or sleeve  $t$  is not to be less than that obtained from the following formula.

$$t = 0.01 \sqrt{B} \quad (\text{mm})$$

where :

$B$  = as specified in **801**.

However,  $t$  is not to be less than  $t_{\min}$  as follows ;

$t_{\min}$  = 8 mm for metallic materials and synthetic materials

$t_{\min}$  = 22 mm for lignum vitae

### Section 10 Rudder Accessories

#### 1001. Rudder carriers [See Guidance]

Suitable rudder carriers are to be provided for supporting the weight of rudder according to the form and the weight of the rudder, and care is to be taken to provide efficient lubrication at the support.

#### 1002. Jumping stoppers [See Guidance]

Suitable arrangements are to be provided to prevent the rudder from jumping due to wave shocks.

### Section 11 Propeller Nozzles

#### 1101. Application

1. The following requirements are applicable to propeller nozzles having an inner diameter of up to 5 m. Nozzles with larger diameters will be specially considered. [See Guidance]
2. Special attention is to be given to the support of fixed nozzles at the hull structures.

#### 1102. Design pressure

1. The design pressure for propeller nozzles is to be determined by the following formula:

$$P_d = c P_{do} \quad (\text{kN/m}^2)$$

$$P_{do} = \epsilon \frac{N}{A_p} \quad (\text{kN/m}^2)$$

$N$  = maximum shaft power (kW)

$A_p$  = propeller disc area (m<sup>2</sup>)

$$A_p = D^2 \frac{\pi}{4}$$

$D$  = propeller diameter (m)

$\epsilon$  = factor according to the following formula:

$$\epsilon = 0.21 - 2 \times 10^{-4} \frac{N}{A_p}$$

$$\epsilon_{\min} = 0.1$$

- $c = 1.0$  in zone 2 (propeller zone)  
 $= 0.5$  in zone 1 & 3  
 $= 0.35$  in zone 4

### 1103. Plate thickness

- (1) The thickness of the nozzle shell plating is not to be less than the greater of the following values and 7.5 mm :

$$t = t_0 + t_k \quad (\text{mm})$$

$$t_0 = 5a \sqrt{P_d} \quad (\text{mm})$$

$a$  = spacing of ring stiffeners (m)

$t_k$  = corrosion allowance (mm)

$$t_k = 1.5, \text{ for } t_0 \leq 10$$

$$t_k = \min \left[ 0.1 \left( \frac{t_0}{\sqrt{K}} + 5 \right), 3.0 \right], \text{ for } t_0 > 10$$

- (2) The web thickness of the internal stiffening rings shall not be less than the nozzles plating for zone 3, however, in no case be less than 7.5 mm.

### 1104. Section modulus

- (1) The section modulus of the cross section shown in **Fig 4.1.6** around its neutral axis is not to be less than:

$$W = n \cdot d^2 \cdot b \cdot V^2 \quad (\text{cm}^3)$$

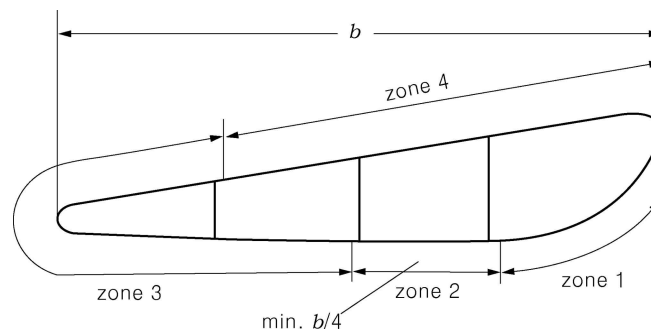
$d$  = inner diameter of nozzle in (m)

$b$  = length of nozzle in (m)

$n = 1.0$  for rudder nozzles

$= 0.7$  for fixed nozzles.

$V$  = speed of ship(Kt) as specified in **201**.



**Fig 4.1.6 Propeller zone**

### 1105. Welding

The inner and outer nozzle shell plating is to be welded to the internal stiffening rings as far as practicable by double continuous welds. Plug welding is only permissible for the outer nozzle plating. ↓

## CHAPTER 2 HATCHWAYS AND OTHER DECK OPENINGS

### Section 1 General

#### 101. Application

1. The requirements apply to all ships except bulk carriers, ore carriers and combination carriers and are for hatch covers and coaming in position 1 and 2 on weather decks. The requirements in **Ch 9** apply to steel hatch covers of small hatches fitted on the exposed fore deck.
2. The construction and means for securing the weathertightness of cargo and other hatchways in position 1 and 2 as defined **102**. shall be equivalent to the requirements of hatchways closed by weathertight covers of steel or other equivalent materials, unless approved by the Administration.  
[See Guidance]

#### 102. Position of exposed deck openings [See Guidance]

For the purpose of this Chapter, two positions of exposed deck openings are defined as follows:

- Position 1 = Upon exposed freeboard and raised quarter decks, and upon exposed superstructure decks situated forward of a point located  $0.25L_f$  from the forward end of  $L_f$ .
- Position 2 = Upon exposed superstructure decks situated abaft  $0.25L_f$  from the forward end of  $L_f$  and upon exposed superstructure decks situated forward of a point located  $0.25L_f$  from the forward end of  $L_f$  and located at least two standard heights of superstructure above the freeboard deck.

#### 103. Height of hatchway coamings

1. The height of coamings above the upper surface of deck is to be not less than followings.  
Position 1 : 600 mm  
Position 2 : 450 mm
2. The height of hatch cover and coamings in exposed portions of higher than the superstructure decks is to be to the satisfaction of the Society.
3. For hatchways closed by steel weathertight hatch covers fitted with gaskets and clamping devices, the height of coamings may be reduced from those prescribed in Par 1 or omitted entirely. In this case, the scantling of hatch cover, gasket, clamping device and drainage to be subject to the satisfaction of the Society.

#### 104. Hatch covers [See Guidance]

1. Hatch covers on exposed decks are to be weathertight.  
Hatch covers in closed superstructures need not be weathertight. However, hatch covers fitted in way of ballast tanks, fuel oil tanks or other tanks are to be watertight.
2. In the case of sand carriers and dredgers, hatchway covers may be omitted at the discretion of the Society.

#### 105. Material

Hatch covers and coamings are to be made of material in accordance with the definitions of **Pt 2 Ch 1** of the Rules. Material class I of **Pt 3 Ch 1 Table 3.1.10** is to be applied for top plate, bottom plate and primary supporting members. The use of materials other than steel is considered by checking that criteria adopted for scantlings are such as to ensure strength and stiffness equivalent to those of steel hatch covers.

#### 106. Net scantlings

1. Unless otherwise quoted, the scantling of this Chapter are net scantlings.

2. The net thicknesses are the member thicknesses necessary to obtain the minimum net scantlings required by **Sec 3** and **Sec 4**.
3. The required gross thicknesses are obtained by adding corrosion additions given in **Table 4.2.1**.
4. Strength calculations using grillage analysis or FEM are to be performed with net scantlings.

### 107. Corrosion additions

1. The corrosion addition for steel hatch covers, hatch coamings is equal to the value specified in **Table 4.2.1**. For structural members made of stainless steel and aluminium alloys, the corrosion addition  $t_c$  is to be taken equal to 0 mm.

#### 2. Renewal thickness

Structural drawings for hatch covers and hatch coamings complying with this Chapter are to indicate the renewal thickness ( $t_{renewal}$ ) for each structural elements, given by the following formula in addition to the as built thickness ( $t_{as-built}$ ). If the thickness for voluntary addition is included in the as built thickness, the value may be at the discretion of the Society.

$$t_{renewal} = t_{as-built} - t_c + 0.5 \quad (\text{mm})$$

where,

$t_c$  : Corrosion addition according to **Table 4.2.1**

In case that corrosion addition  $t_c$  is 1.0 mm, renewal thickness may be given by the following formula.

$$t_{renewal} = t_{as-built} - t_c \quad (\text{mm})$$

**Table 4.2.1 Corrosion additions  $t_c$  for hatch covers and hatch coamings**

Application	Structure	$t_c$ (mm)
Container ships, car carriers, paper carriers, passenger vessels	Hatch covers	1.0
	Hatch coamings	1.5
All other ship types	Single skin hatch covers	2.0
	Top plating and bottom plating of double skin hatch covers	1.5
	Internal structure of double skin hatch covers and closed box girders	1.0
	Hatch coaming parts including stays and stiffeners	1.5

### 3. Steel renewal

- (1) The treatment in relation to gauged thickness are to be obtained from **Table 4.2.2**.
- (2) Where applied protection coating, coating applied in accordance with the coating manufacturer's requirements. Coating is to be maintained in GOOD condition, as defined in **Pt 1, Ch 2, 101.16** of the Rules.
- (3) For the internal structure of double skin hatch covers, thickness gauging is required when hatch cover top or bottom plating renewal is to be carried out or when this is deemed necessary, at the discretion of the Society's surveyor, on the basis of the plating corrosion or deformation condition. In these cases, steel renewal for the internal structures is required where the gauged thickness is less than  $t_{net}$ . **[See Guidance]**

Table 4.2.2. Treatment in relation to gauged thickness

Treatment	Where $t_c \geq 1.5 \text{ mm}$	Where $t_c = 1.0 \text{ mm}$
Steel renewal	$t_g < t_{net} + 0.5 \text{ mm}$	$t_g \leq t_{net}$
Apply protection coating or annual gauging	$t_{net} + 0.5 < t_g < t_{net} + 1.0 \text{ mm}$	$t_{net} < t_g < t_{net} + 0.5 \text{ mm}$

## Section 2 Design Load

### 201. Hatch cover and coaming design load

1. Design load of hatch covers and hatch coamings is to be not less than the value obtained from 202. to 206.

#### 2. Definitions

- $x$  = longitudinal co-ordinate of mid point of assessed structural member measured from aft end of length  $L$  or  $L_f$ , as applicable
- $h_N$  = standard superstructure height(m)  
 $= 1.05 + 0.01L_{LL}$ ,  $1.8 \leq h_N \leq 2.3$
- $D_{min}$  = minimum depth found by drawing a line parallel to the keel line of the vessel(including skeg) tangent to the moulded sheer line of the freeboard deck

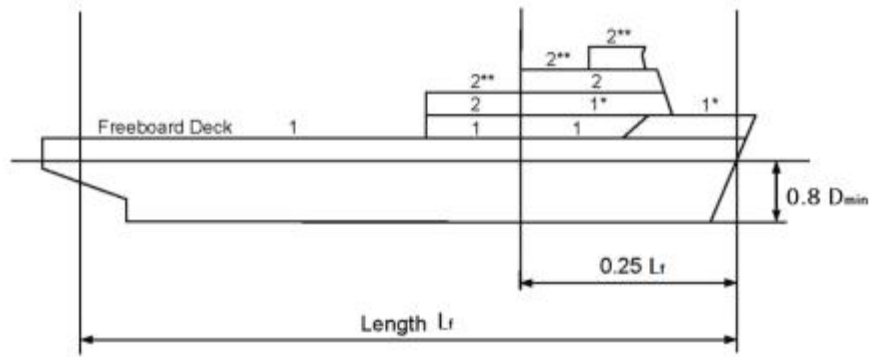
### 202. Vertical weather design load

1. The vertical weather load on the hatch cover panels is given by Table 4.2.3.
2. The vertical weather design load needs not to be combined with cargo loads according to 204. and 205.
3. Where an increased freeboard is assigned, the design load for hatch covers according to Table 4.2.3 on the actual freeboard deck may be as required for a superstructure deck, provided the summer freeboard is such that the resulting draught will not be greater than that corresponding to the minimum freeboard calculated from an assumed freeboard deck situated at a distance at least equal to the standard superstructure height  $h_N$  below the actual freeboard deck, see Fig 4.2.2.

Table 4.2.3 Vertical weather load  $p_H$  of weather deck hatches

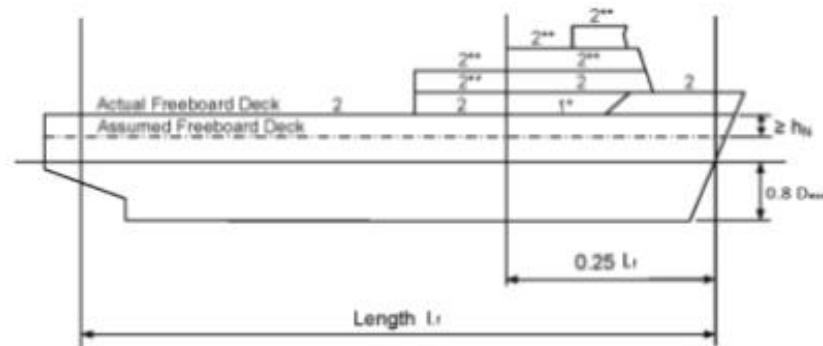
Position	$L_f$ (m)	Vertical weather load $P_V$ (kN/m <sup>2</sup> )	
		$\frac{x}{L_f} \leq 0.75$	$0.75 < \frac{x}{L_f} \leq 1.0$
1	$24 \text{ m} \leq L_f \leq 100 \text{ m}$	$\frac{9.81}{76}(1.5L_f + 116)$	on freeboard deck $\frac{9.81}{76} \left[ (4.28L_f + 28) \frac{x}{L_f} - 1.71L_f + 95 \right]$
			upon exposed superstructure decks located at least one superstructure standard height above the freeboard deck(*) $\frac{9.81}{76}(1.5L_f + 116)$
	$L_f > 100 \text{ m}$	34.3 (9.81 × 3.5)	on freeboard deck for type B ships $9.81 \left[ (0.0296L_1 + 3.04) \frac{x}{L_f} - 0.0222L_1 + 1.22 \right]$
			on freeboard deck for type B-60 or B-100 ships $9.81 \left[ (0.1452L_1 - 8.52) \frac{x}{L_f} - 0.1089L_1 + 9.89 \right]$ $L_1 = L_f$ but not more than 340 m
			upon exposed superstructure decks located at least one superstructure standard height above the freeboard deck(*) 34.3 (9.81 × 3.5)
2	$24 \text{ m} \leq L_f \leq 100 \text{ m}$		$\frac{9.81}{76}(1.1L_f + 87.6)$
	$L_f > 100 \text{ m}$		(9.81 × 2.6)
			upon exposed superstructure decks located at least one superstructure standard height above the lowest Position 2 deck(**) 20.6(9.81 × 2.1)

(Remark) (\*), (\*\*) means \*, \*\* of Fig 4.2.1 and Fig. 4.2.2



- \* reduced load upon exposed superstructure decks located at least one superstructure standard height above the freeboard deck
- \*\* reduced load upon exposed superstructure decks of vessels with  $L_f > 100\text{m}$  located at least one superstructure standard height above the lowest Position 2 deck

Fig 4.2.1 Positions 1 and 2



- \* reduced load upon exposed superstructure decks located at least one superstructure standard height above the freeboard deck
- \*\* reduced load upon exposed superstructure decks of vessels with  $L_f > 100\text{m}$  located at least one superstructure standard height above the lowest Position 2 deck

Fig 4.2.2 Positions 1 and 2 for an increased freeboard

### 203. Horizontal weather design load

The horizontal weather load is obtained from the following formulae and not to be less than the values given by **Table 4.2.4**. The horizontal weather design load need not be included in the direct strength calculation of the hatch cover, unless it is utilized for the design of substructures of horizontal support according to **505**.

$$P_H = ac(bc_L f - z)$$

$$f = \frac{L}{25} + 4.1 \quad \text{for } L < 90 \text{ m}$$

$$= 10.75 - \left( \frac{300 - L}{100} \right)^{1.5} \quad \text{for } 90 \text{ m} \leq L < 300 \text{ m}$$

$$= 10.75 \quad \text{for } 300 \text{ m} \leq L < 350 \text{ m}$$

$$= 10.75 - \left( \frac{L - 350}{150} \right)^{1.5} \quad \text{for } 350 \text{ m} \leq L \leq 500 \text{ m}$$

$$c_L = \sqrt{\frac{L}{90}} \quad \text{for } L < 90 \text{ m}$$

$$= 1 \quad \text{for } L \geq 90 \text{ m}$$

$$a = 20 + \frac{L_1}{12} \quad \text{for unprotected front coamings and hatch cover skirt plates}$$

$$a = 10 + \frac{L_1}{12} \quad \text{for unprotected front coamings and hatch cover skirt plates, where the distance from the actual freeboard deck to the summer load line exceeds the minimum non-corrected tabular freeboard according to ICLL by at least one standard superstructure height } h_N$$

$$a = 5 + \frac{L_1}{15} \quad \text{for side and protected front coamings and hatch cover skirt plates}$$

$$a = 7 + \frac{L_1}{100} - 8 \frac{x'}{L} \quad \text{for aft ends of coamings and aft hatch cover skirt plates abaft amidships}$$

$$a = 5 + \frac{L_1}{100} - 4 \frac{x'}{L} \quad \text{for aft ends of coamings and aft hatch cover skirt plates forward of amidships}$$

$L_1$  = length of ship, need not be taken greater than 300 m

$$b = 1.0 + \left( \frac{x'/L - 0.45}{C_{bl} + 0.2} \right)^2 \quad \text{for } \frac{x'}{L} < 0.45$$

$$= 1.0 + 1.5 \left( \frac{x'/L - 0.45}{C_{bl} + 0.2} \right)^2 \quad \text{for } \frac{x'}{L} \geq 0.45$$

$0.6 \leq C_{bl} \leq 0.8$ , when determining scantlings of aft ends of coamings and aft hatch cover skirt plates forward of amidships,  $C_{bl}$  need not be taken less than 0.8.

$x'$  = distance in m between the transverse coaming or hatch cover skirt plate considered and aft end of the length  $L$ . When determining side coamings or side hatch cover skirt plates, the side is to be subdivided into parts of approximately equal length, not exceeding  $0.15 L$  each, and  $x'$  is to be taken as the distance between aft end of the length  $L$  and the centre of each part considered.

$z$  = vertical distance in m from the summer load line to the midpoint of stiffener span, or to the middle of the plate field

$$c = 0.3 + 0.7b'/B'$$

$b'$  = breadth of coaming in m at the position considered

$B'$  = actual maximum breadth of ship in m on the exposed weather deck at the position considered.

$b'/B'$  is not to be taken less than 0.25.

**Table 4.2.4 Minimum horizontal weather design load  $P_{Hmin}$**

$L$	$P_{Hmin}$ (kN/m <sup>2</sup> )	
	unprotected fronts hatch coaming and hatch cover skirt plates	elsewhere
$\leq 50$	30	15
$50 < L < 250$	$25 + \frac{L}{10}$	$12.5 + \frac{L}{20}$
$\geq 250$	50	25

## 204. Cargo loads

The load due to cargo load on hatch covers is to be accordance with Par 1, 2 and partial cargo load to be considered with together.

### 1. Distributed loads

The load on hatch covers due to distributed cargo loads  $P_L$  resulting from heave and pitch is to be determined according to the following formula:

$$P_L = P_C(1 + a_V) \quad (\text{kN/m}^2)$$

$$P_C = \text{uniform static cargo load}(\text{kN/m}^2)$$

$a_V$  = acceleration addition as follows:

$$a_V = 0.11 \frac{m V_1}{\sqrt{L}}$$

$$m = m_0 - 5(m_0 - 1) \frac{x}{L} \quad \text{for } 0 \leq \frac{x}{L} \leq 0.2$$

$$= 1.0 \quad \text{for } 0.2 < \frac{x}{L} \leq 0.7$$

$$= 1 + \frac{m_0 + 1}{0.3} \left[ \frac{x}{L} - 0.7 \right] \quad \text{for } 0.7 < \frac{x}{L} \leq 1.0$$

$$m_0 = 1.5 + 0.11 V_1 / \sqrt{L}$$

$$V_1 = \text{max. speed of ship,}$$

$$V_1 \text{ is not to be taken less than } \sqrt{L} (\text{kN})$$

### 2. Point loads

The loads due to single forces  $P$  resulting from heave and pitch (i.e. ship in upright condition) are to be determined as follows:

$$P = P_S(1 + a_V) \quad (\text{kN})$$

$$P_S = \text{static point loads due to cargo loads}(\text{kN})$$

$a_V$  = acceleration addition given in **Par 1**

## 205. Container loads

The loads defined in the followings are to be applied where containers are stowed on the hatch cover.

1. The load applied at each corner of a container stack, and resulting from heave and pitch(i.e. ship in upright condition)is to be determined as follows:

$$P = 9.81 \times \frac{M}{4} (1 + a_V) \quad (\text{kN})$$

$a_V$  = acceleration addition given in **204. 1**

$M$  = maximum designed mass of container stack (t)

2. Where containers are stowed on hatch covers the following loads (kN) due to heave, pitch, and the ship's rolling motion(i.e. ship in heel condition) are to be considered, see also **Fig 4.2.3**.

$$A_z = 9.81 \frac{M}{2} \cdot (1 + a_V) \cdot \left( 0.45 - 0.42 \frac{h_m}{b} \right)$$

$$B_z = 9.81 \frac{M}{2} \cdot (1 + a_V) \cdot \left( 0.45 + 0.42 \frac{h_m}{b} \right)$$

$$B_y = 2.4 \cdot M$$

$a_V$  = acceleration addition according to **204. 1**

$M$  = maximum designed mass of container stack (t)

$$= \sum W_i$$

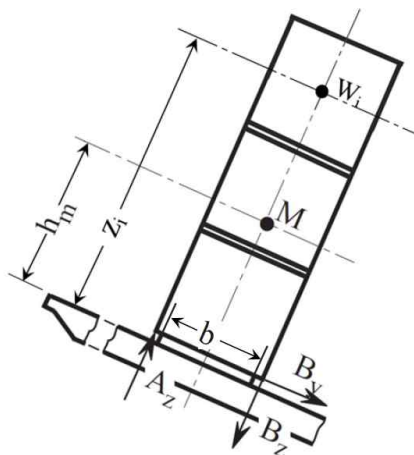
$h_m$  = designed height of centre of gravity of stack above hatch cover supports (m)

$$= \frac{\sum (z_i \times W_i)}{M}$$

$z_i$  = distance from hatch cover top to the centre of  $i$ th container (m)

$W_i$  = weight of  $i$ th container (t)

3. When strength of the hatch cover structure is assessed by grillage analysis according to **306.**,  $h_m$  and  $z_i$  need to be taken above the hatch cover supports. Forces  $B_y$  does not need to be considered in this case.
4. Values of  $A_z$  and  $B_z$  applied for the assessment of hatch cover strength are to be shown in the drawings of the hatch covers.



**Fig 4.2.3 Forces due to container loads**

5. It is recommended that container loads  $A_z$ ,  $B_z$  and  $B_y$  as calculated above are considered as limit

for foot point loads of container stacks in the calculations of cargo securing (container lashing).

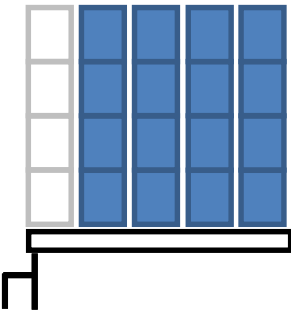
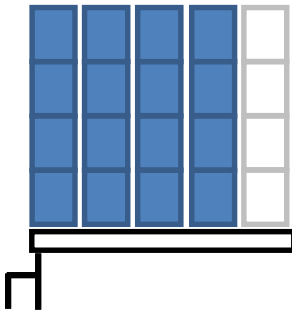
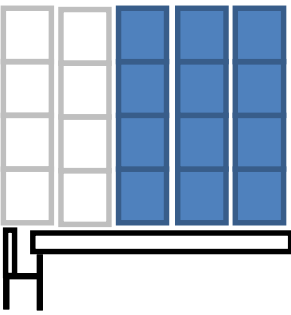
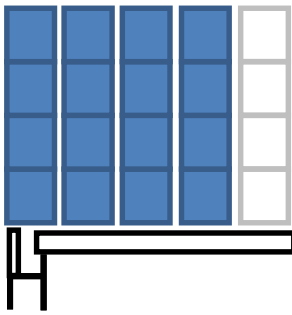
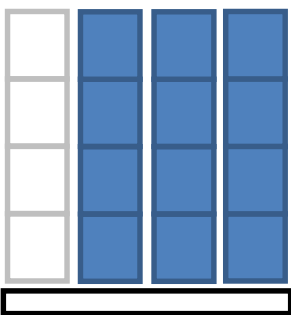
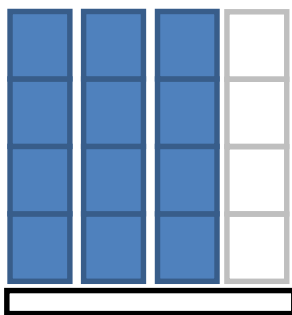
#### **6. Partial loading**

- (1) The load cases defined in **Par 1 to 5** are also to be considered for partial non homogeneous loading which may occur in practice, e.g. where specified container stack places are empty.
- (2) For each hatch cover, the heel directions, as shown in **Table 4.2.5**, are to be considered.
- (3) The load case partial loading of container hatch covers can be evaluated using a simplified approach, where the hatch cover is loaded without the outermost stacks that are located completely on the hatch cover.
- (4) If there are additional stacks that are supported partially by the hatch cover and partially by container stanchions then the loads from these stacks are also to be neglected, refer to **Table 4.2.5**.
- (5) In addition, the case where only the stack places supported partially by the hatch cover and partially by container stanchions are left empty is to be assessed in order to consider the maximum loads in the vertical hatch cover supports.
- (6) It may be necessary to also consider partial load cases where more or different container stack places are left empty. Therefore, the Society may require that additional partial load cases be considered.

#### **7. Mixed stowage of 20' and 40' containers on hatch cover**

In the case of mixed stowage (20'+40' container combined stack), the foot point forces at the fore and aft end of the hatch cover are not to be higher than resulting from the design stack weight for 40' containers, and the foot point forces at the middle of the cover are not to be higher than resulting from the design stack weight for 20' containers.

Table 4.2.5 Partial loading of container hatch covers

Heel direction	←	→
Hatch covers supported by the longitudinal hatch coaming with all container stacks located completely on the hatch cover		
Hatch covers supported by the longitudinal hatch coaming with the outermost container stack supported partially by the hatch cover and partially by container stanchions		
Hatch covers not supported by the longitudinal hatch coaming (center hatch covers)		

### 206. Loads due to elastic deformations of the ship's hull

Hatch covers, which in addition to the loads according to 202. to 205. are loaded in the ship's transverse direction by forces due to elastic deformations of the ship's hull, are to be designed such that the sum of stresses does not exceed the permissible values given in 302. 1.

## Section 3 Hatch cover strength criteria

### 301. General

1. The ordinary stiffeners and primary supporting members of the hatch covers are to be continuous over the breadth and length of the hatch covers, as far as practical. When this is impractical, snipped end connections are not to be used and appropriate arrangements are to be adopted to ensure sufficient load carrying capacity.
2. The spacing of primary supporting members parallel to the direction of ordinary stiffeners is to be not greater than 1/3 of the span of primary supporting members. When strength calculation is carried out by FE analysis using plane strain or shell elements, this requirement can be waived.

3. The breadth of the primary supporting member flange is to be not less than 40 % of their depth for laterally unsupported spans greater than 3 m. Tripping brackets attached to the flange may be considered as a lateral support for primary supporting members. The flange outstand is not to exceed 15 times the gross flange thickness.

### 302. Permissible stresses and deflections

#### 1. Permissible Stresses

The equivalent stress  $\sigma_E$  in steel hatch cover shall be accordance with the following requirements.

- (1) For grillage analysis

$$\sigma_E = \sqrt{\sigma^2 + 3\tau^2} \leq 0.8\sigma_Y \quad (\text{N/mm}^2)$$

$\sigma$  = normal stress (N/mm<sup>2</sup>)

$\tau$  = shear stress (N/mm<sup>2</sup>)

$\sigma_Y$  = minimum yield stress of the material (N/mm<sup>2</sup>)

- (2) For FEM calculations

- (A) For vertical weather load according to **202**.

$$\sigma_E = \sqrt{\sigma_x^2 - \sigma_x\sigma_y + \sigma_y^2 + 3\tau^2} \leq 0.8\sigma_Y \quad (\text{N/mm}^2)$$

- (B) For other than **202**.

$$\sigma_E = \sqrt{\sigma_x^2 - \sigma_x\sigma_y + \sigma_y^2 + 3\tau^2} \leq 0.9\sigma_Y \quad (\text{N/mm}^2)$$

$\sigma_x, \sigma_y$  = normal stress on each in x-direction, y-direction

$x, y$  = coordinates of a two-dimensional Cartesian system in the plane of the considered structural element.

- (3) In case of FEM calculations using shell or plane strain elements, the stresses are to be read from the centre of the individual element. Where shell elements are used, the stresses are to be evaluated at the mid plane of the element.
- (4) It is to be observed that, in particular, at flanges of unsymmetrical girders, the evaluation of stress from element centre may lead to non-conservative results. Thus, a sufficiently fine mesh is to be applied in these cases or, the stress at the element edges shall not exceed the allowable stress.
- (5) Stress concentrations are to be assessed to the satisfaction of the Society.

#### 2. Deflection

- (1) The vertical deflection of primary supporting members due to the vertical weather design load according to **202**. is to be not more than the following formulae.

$$\delta = 0.0056l_g \quad (\text{m})$$

$l_g$  = greatest span of primary supporting members

- (2) Where hatch covers are arranged for carrying containers and mixed stowage is allowed, i.e., a 40' container stowed on top of two 20' containers, particular attention should be paid to the deflections of hatch covers. Further the possible contact of deflected hatch covers with in hold cargo has to be observed.

### 303. Net plate thickness of hatch cover

1. The local net plate thickness  $t$ (mm) of the hatch cover top plating is not to be less than:

$$t = 15.8 F_p S \sqrt{\frac{P}{0.95 \sigma_y}} \quad (\text{mm})$$

and to be not less than 1 % of the spacing of the stiffener or 6 mm if that be greater.

$F_p$  = factor for combined membrane and bending response

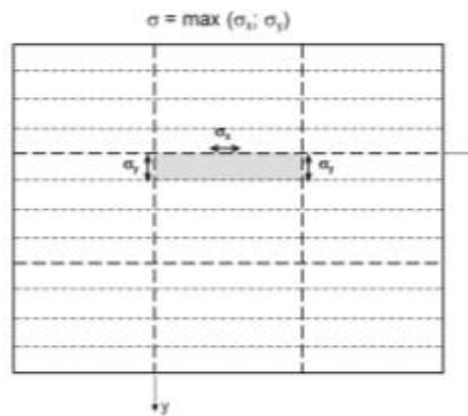
= 1.5 in general

=  $1.9\sigma / (0.8\sigma_y)$ , for  $\frac{\sigma}{\sigma_a} \geq 0.8$  for the attached plate flange of primary supporting members

$S$  = stiffener spacing (m)

$p$  = pressure  $P_V$  and  $P_L$  (kN/m<sup>2</sup>) as defined in **202.** and **204. 1.**

$\sigma$  = normal stress(N/mm<sup>2</sup>) of hatch cover top plating as determined by **Fig 4.2.4**



**Fig 4.2.4** Determination of normal stress of the hatch cover plating

2. For plates under compression buckling strength according to **307.** is to be demonstrated.

### 3. Lower plating of double skin hatch covers and box girders

- (1) The thickness to fulfill the strength requirements is to be obtained from the calculation according to **302. 1** under consideration of permissible stresses according to **306.**
- (2) The net thickness must not be less than 5 mm when the lower plating is taken into account as a strength member of the hatch cover.
- (3) When project cargo is intended to be carried on a hatch cover, the net thickness must not be less than the following formulae. Project cargo means especially large or bulky cargo lashed to the hatch cover. Examples are parts of cranes or wind power stations, turbines, etc. Cargoes that can be considered as uniformly distributed over the hatch cover, e.g., timber, pipes or steel coils need not to be considered as project cargo.

$$t = 6.5 S \quad (\text{mm})$$

$S$  = stiffener spacing (m)

- (4) When the lower plating is not considered as a strength member of the hatch cover, the thickness of the lower plating should be determined according to the Society. **[See Guidance]**

### 4. Local net plate thickness of hatch covers for wheel loading **[See Guidance]**

The local net plate thickness of hatch covers for wheel loading have to be derived from the Society.

**304. Net scantling of stiffeners**

1. The net section modulus  $Z$  and net shear area  $A$  of hatch cover stiffeners must not be less than. The net section modulus of the stiffeners is to be determined based on an attached plate width assumed equal to the stiffener spacing.

(1) For vertical weather load according to **202.**

$$Z = \frac{104}{\sigma_y} P S l^2 \quad (\text{cm}^3)$$

$$A = \frac{10.8 P S l}{\sigma_y} \quad (\text{cm}^2)$$

(2) For cargo load according to **204. 1**

$$Z = \frac{93}{\sigma_y} P S l^2 \quad (\text{cm}^3)$$

$$A = \frac{9.6 P S l}{\sigma_y} \quad (\text{cm}^2)$$

$l$  = stiffener span (m) to be taken as the spacing of primary supporting members

$S$  = stiffener spacing (m)

$P$  = pressure  $P_V$  and  $P_L$  (kN/m<sup>2</sup>) as defined in **202.**, **204. 1**.

2. For stiffeners of lower plating of double skin hatch covers, requirements mentioned above are not applied due to the absence of lateral loads. The requirements of **Par 5, 6** are not applied to stiffeners of lower plating of double skin hatch covers if the lower plating is not considered as strength member.
3. The net thickness of the stiffener (except u-beams/trapeze stiffeners) web is to be taken not less than 4 mm.
4. The flat bar stiffeners and buckling stiffeners shall be accordance with following formulae.

$$h/t_w < 15 \sqrt{(235/\sigma_y)}$$

$h$  = height of the stiffener (mm)

$t_w$  = net thickness of the stiffener (mm)

5. Stiffeners parallel to primary supporting members and arranged within the effective breadth according to **305. 1** must be continuous at crossing primary supporting member and may be regarded for calculating the cross sectional properties of primary supporting members.
6. Where apply to **Par 5**, It is to be verified that the combined stress of those stiffeners induced by the bending of primary supporting members and lateral pressures does not exceed the permissible stresses according to **302. 1**.
7. For hatch cover stiffeners under compression sufficient safety against lateral and torsional buckling according **307. 5** (3), (4) is to be verified.
8. For hatch covers subject to wheel loading or point loading stiffener scantlings are to be determined by direct calculations under consideration of the permissible stresses according to **302. 1** or are to be determined according to the Society.

### 305. Net scantling of primary supporting members

#### 1. Primary supporting members

- (1) Scantlings of primary supporting members are obtained from calculations according to **306.** under consideration of permissible stresses according to **302. 1.**
- (2) For all components of primary supporting members sufficient safety against buckling must be verified according to **307.** For biaxial compressed attach plates this is to be verified within the effective widths according to **307. 5. (2).**
- (3) The net thickness (mm) of webs of primary supporting members shall not be less than:

$$t = 6.5 \times s \text{ (mm)}$$

$$t_{\min} = 5 \text{ mm}$$

$$s = \text{stiffener spacing (m)}$$

#### 2. Skirt plates fo hatch cover

- (1) Scantlings of edge girders are obtained from the calculations according to **306.** under consideration of permissible stresses according to **302. 1.**
- (2) The net thickness, in mm, of the outer edge girders exposed to wash of sea shall not be less than the largest of the following values:

$$t = 15.8S \sqrt{\frac{P_H}{0.95\sigma_Y}} \text{ (mm)}$$

$$t = 8.5S \text{ (mm)}$$

$$t_{\min} = 5 \text{ mm}$$

$$P_H = \text{horizontal weather load as defined in } \mathbf{203.}$$

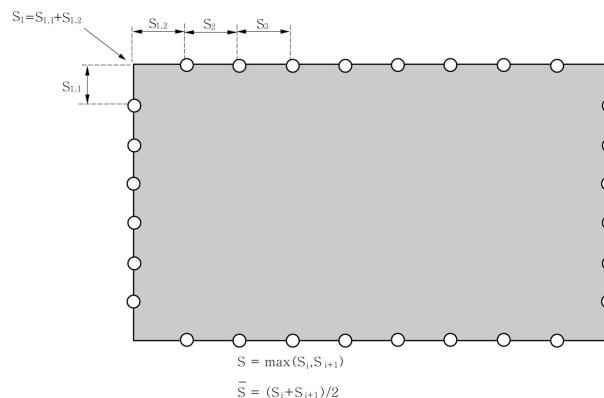
$$S = \text{stiffener spacing (m)}$$

- (3) The stiffness of edge girders is to be sufficient to maintain adequate sealing pressure between clamping devices. The moment of inertia of skirt plates is not to be less than:

$$I = 6qS_{SD}^4 \text{ (cm}^4\text{)}$$

$q$  = line pressure on gasket (N/mm), minimum 5 N/mm

$S_{SD}$  = spacing(m) of clamping devices, but  $S_{SD}$  is not to be less than  $2.5a_c$ (see **Fig 4.2.5**)



**Fig 4.2.5 Spacing of clamping device**

#### 3. Primary supporting members and skirt plates of variable cross-section

The net section modulus of primary supporting members with a variable cross-section is to be not less than the greater of the value obtained from the following formulae and the use of these formulae is limited to the determination of the strength of primary supporting members in which abrupt changes in the

cross-section.

(1) Net section modulus

$$Z = Z_{CS} \quad (\text{cm}^3)$$

$$Z = \left(1 + \frac{3.2\alpha - \psi - 0.8}{7\psi + 0.4}\right) Z_{CS} \quad (\text{cm}^3)$$

(2) Net moment of inertia

$$I = I_{CS} \quad (\text{cm}^4)$$

$$I = \left(1 + 8 \alpha^3 \left(\frac{1 - \phi}{0.2 + 3\sqrt{\phi}}\right)\right) I_{CS} \quad (\text{cm}^4)$$

$Z_{CS}$  : Net section modulus( $\text{cm}^3$ ) of primary supporting stiffener complying with the checking criteria in **Par 1. (1) or Par 2. (1)**

$$\alpha = \frac{l_1}{l_0}$$

$$\psi = \frac{Z_1}{Z_0}$$

$l_1$  : Length of the variable section part(m) (see **Fig 4.2.6**)

$l_0$  : Span measured(m) between end supports (see **Fig 4.2.6**)

$Z_1$  : Net section modulus at end( $\text{cm}^3$ ) (see **Fig 4.2.6**)

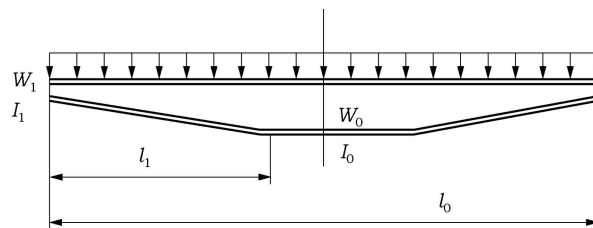
$Z_0$  : Net section modulus calculated with considering the net thickness at mid-span( $\text{cm}^3$ ) (see **Fig 4.2.6**)

$I_{CS}$  : Net moment of inertia of primary supporting stiffener complying with the checking criteria in **Par 1. (1) or Par 2. (1)**

$$\phi = \frac{I_1}{I_0}$$

$I_1$  : Net moment of inertia at end ( $\text{cm}^4$ ) (see **Fig 4.2.6**)

$I_0$  : Net moment of inertia at mid-span between supports ( $\text{cm}^4$ ) (see **Fig 4.2.6**)



**Fig 4.2.6 Variable cross-section stiffener**

### 306. Strength calculations

Strength calculation for hatch covers may be carried out by either, using grillage analysis or FEM. Double skin hatch covers or hatch covers with box girders are to be assessed using FEM, refer to **Par 2.**

#### 1. Effective cross-sectional properties for calculation by grillage analysis

(1) Cross-sectional properties are to be determined considering the effective breadth. Cross sectional areas of secondary stiffeners parallel to the primary supporting member under consideration within the effective breadth can be included, refer **Fig 4.2.8.**

- (2) The effective breadth of plating  $e_m$  of primary supporting members is to be determined according to **Table 4.2.6**, considering the type of loading. The intermediate value of  $l/e$  may be obtained by direct interpolation. The effective breadth of one-sided flanges is to be taken equal to the lesser of the following values.
  - (A) 0.165 times of span between considered primary supporting member
  - (B) Half the distance between the adjacent primary member
- (3) The effective cross sectional area of plates is not to be less than the cross sectional area of the face plate.
- (4) For flange plates under compression with secondary stiffeners perpendicular to the web of the primary supporting member, the effective width is to be determined according to **307. 5. (2)**.

**2. General requirements for FEM calculations**

- (1) For strength calculations of hatch covers by means of finite elements, the cover geometry shall be idealized as realistically as possible.
- (2) Element size must be appropriate to account for effective breadth. In no case element width shall be larger than stiffener spacing. The ratio of element length to width shall not exceed 4.
- (3) In way of force transfer points and cutouts the mesh has to be refined where applicable.
- (4) The element height of webs of primary supporting member must not exceed one-third of the web height.
- (5) Stiffeners, supporting plates against pressure loads, have to be modelled. Stiffeners may be modelled by using shell elements, plane stress elements or beam elements.
- (6) Buckling stiffeners may be disregarded for the stress calculation.

**Table 4.2.6 Effective breadth  $e_m$  of plating of primary supporting members**

$l/e$	0	1	2	3	4	5	6	7	$\geq 8$
$e_{m1}/e$	0	0.36	0.64	0.82	0.91	0.96	0.98	1.00	1.00
$e_{m2}/e$	0	0.20	0.37	0.52	0.65	0.75	0.84	0.89	0.90

$e_{m1}$  is to be applied where primary supporting members are loaded by uniformly distributed loads or else by not less than 6 equally spaced single loads

$e_{m2}$  is to be applied where primary supporting members are loaded by 3 or less single loads Intermediate values may be obtained by direct interpolation.

$l$  effective span of primary supporting member  
 $l = l_0$  for simply supported primary supporting members  
 $l = 0.6 \cdot l_0$  for primary supporting members with both ends constraint,  
 where  $l_0$  is the distance between supporting points of the primary supporting member

$e$  width of plating supported, measured from centre to centre of the adjacent unsupported fields

**307. Buckling strength of hatch cover**

1. For hatch cover structures sufficient buckling strength is to be demonstrated.

**2. Definitions(refer Fig 4.2.7)**

- $a$  = length of the longer side of a single plate field (mm) (x-direction)
- $b$  = breadth of the shorter side of a single plate field (mm) (y-direction)
- $\alpha$  = aspect ratio of single plate field  
 $= a/b$
- $n$  = number of single plate field breadths within the partial or total plate field
- $t$  = net plate thickness in mm
- $\sigma_x, \sigma_y, \tau$  = membrane stress(N/mm<sup>2</sup>) in x-direction, y-direction and shear stress(N/mm<sup>2</sup>) in the x-y plane. Compressive and shear stresses are to be taken positive, tension stresses are to be taken negative. If stresses in the x- and y-direction already contain the Poisson-effect (calculated using FEM), the following modified stress values may be used. Both stresses

$\sigma_x^*$  and  $\sigma_y^*$  are to be compressive stresses, in order to apply the stress reduction according to the following formulae:

$$\sigma_x = (\sigma_x^* - 0.3 \cdot \sigma_y^*) / 0.91$$

$$\sigma_y = (\sigma_y^* - 0.3 \cdot \sigma_x^*) / 0.91$$

$\sigma_x^*$ ,  $\sigma_y^*$  = stresses containing the Poisson-effect

Where  $\sigma_y^* < 0.3 \sigma_x^*$ , then  $\sigma_y = 0$  and  $\sigma_x = \sigma_x^*$

Where  $\sigma_x^* < 0.3 \sigma_y^*$ , then  $\sigma_x = 0$  and  $\sigma_y = \sigma_y^*$

$E$  = modulus of elasticity(N/mm<sup>2</sup>) of the material

= 2.06 · 10<sup>5</sup> N/mm<sup>2</sup> for steel

$\sigma_Y$  = minimum yield stress(N/mm<sup>2</sup>) of the material

$F_1$  = correction factor for boundary condition at the longitudinal stiffeners according to **Table 4.2.7.**

Compressive and shear stresses are to be taken positive, tension stresses are to be taken negative.

$\sigma_e$  = reference stress(N/mm<sup>2</sup>) taken equal to

$$= 0.9 \cdot E \left( \frac{t}{b} \right)^2$$

$\Psi$  = each edge stress ratio taken equal to

$$= \sigma_2 / \sigma_1$$

where

$\sigma_1$  = maximum compressive stress

$\sigma_2$  = minimum compressive stress or tension stress

$S$  = safety factor (based on net scantling approach), taken equal to

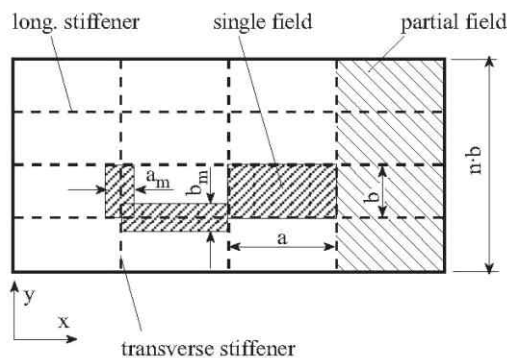
= 1.25 for hatch covers when subjected to the vertical weather design load according to **202.**

= 1.10 for hatch covers when subjected to loads according to **204.** to **206.**

$\lambda$  = reference degree of slenderness, taken equal to:

$$= \sqrt{\frac{\sigma_F}{K \cdot \sigma_e}}$$

$K$  = buckling factor according to **Table 4.2.9.**



longitudinal : stiffener in the direction of the length a  
 transverse : stiffener in the direction of the breadth b

**Fig 4.2.7 General arrangement of panel**

**Table 4.2.7 Correction factor  $F_1$**

Stiffeners sniped at both ends	1.00
Guidance values <sup>1</sup> where both ends are effectively connected to adjacent structures	1.05 for flat bars 1.10 for bulb sections 1.20 for angle and tee-sections 1.30 for u-type sections <sup>2</sup> and girders of high rigidity
<sup>1</sup> Exact values may be determined by direct calculations <sup>2</sup> Higher value may be taken if it is verified by a buckling strength check of the partial plate field using non-linear FEA and deemed appropriate by the Society but not greater than 2.0 <sup>3</sup> An average value of $F_1$ is to be used for plate panels having different edge stiffeners	

**3. Proof of top and lower hatch cover plating**

Proof is to be provided that the following condition is complied with for the single plate field :

$$\left(\frac{|\sigma_x|S}{k_x\sigma_Y}\right)^{e_1} + \left(\frac{|\sigma_y|S}{k_y\sigma_Y}\right)^{e_2} - B\left(\frac{\sigma_x\sigma_y S^2}{\sigma_Y^2}\right) + \left(\frac{|\tau|S\sqrt{3}}{\kappa_\tau\sigma_Y}\right)^{e_3} \leq 1.0$$

$$\left(\frac{|\sigma_x|S}{k_x\sigma_Y}\right)^{e_1} \leq 1.0$$

$$\left(\frac{|\sigma_y|S}{k_y\sigma_Y}\right)^{e_2} \leq 1.0$$

$$\left(\frac{|\tau|S\sqrt{3}}{\kappa_\tau\sigma_Y}\right)^{e_3} \leq 1.0$$

$\kappa_x$ ,  $\kappa_y$  and  $\kappa_\tau$  = reduction factors are given in **Table 4.2.9**

Where  $\sigma_x \leq 0$  (tension stress),  $\kappa_x = 1.0$ .

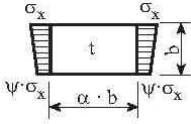
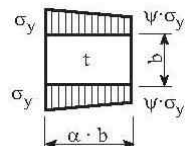
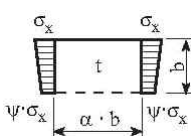
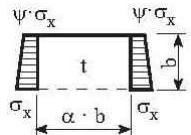
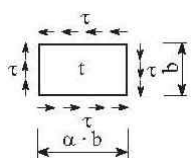
Where  $\sigma_y \leq 0$  (tension stress),  $\kappa_y = 1.0$ .

$e_1$ ,  $e_2$ ,  $e_3$  and  $B$  = according to **Table 4.2.8**

**Table 4.2.8 Coefficients  $e_1$ ,  $e_2$ ,  $e_3$  and factor  $B$**

Exponents $e_1 - e_3$ and factor $B$	Plate panel
$e_1$	$1 + \kappa_x^4$
$e_2$	$1 + \kappa_y^4$
$e_3$	$1 + \kappa_x \cdot \kappa_y \cdot \kappa_\tau^2$
$B$ $\sigma_x$ and $\sigma_y$ positive (compression stress)	$(\kappa_x \cdot \kappa_y)^5$
$B$ $\sigma_x$ or $\sigma_y$ negative (tension stress)	1

Table 4.2.9 Buckling and reduction factors for plane elementary plate panels

Buckling-Load Case	Edge stress ratio $\Psi$	Asp. ratio $\alpha = a/b$	Buckling factor $K$	Reduction factor $\kappa$
	$1 \geq \Psi \geq 0$	$\alpha \geq 1$	$K = \frac{8.4}{\Psi + 1.1}$	$\kappa_x = 1$ for $\lambda \leq \lambda_c$ $\kappa_x = c \left( \frac{1}{\lambda} - \frac{0.22}{\lambda^2} \right)$ for $\lambda > \lambda_c$ $c = (1.25 - 0.12\Psi) \leq 1.25$ $\lambda_c = \frac{c}{2} \left( 1 + \sqrt{1 - \frac{0.88}{c}} \right)$
	$0 > \Psi > -1$		$K = 7.63 - \Psi(6.26 - 10\Psi)$	
	$\Psi \leq -1$		$K = (1 - \Psi)^2 \cdot 5.975$	
	$1 \geq \Psi \geq 0$	$\alpha \geq 1$	$K = F_1 \left( 1 + \frac{1}{\alpha^2} \right)^2 \cdot \frac{2.1}{(\Psi + 1.1)}$	$\kappa_y = c \left( \frac{1}{\lambda} - \frac{R + F^2(H - R)}{\lambda^2} \right)$ $c = (1.25 - 0.12\Psi) \leq 1.25$ $R = \lambda \left( 1 - \frac{\lambda}{c} \right)$ for $\lambda < \lambda_c$ $R = 0.22$ for $\lambda \geq \lambda_c$ $\lambda_c = \frac{c}{2} \left( 1 + \sqrt{1 - \frac{0.88}{c}} \right)$ $F = \left( 1 - \frac{\frac{K}{0.91} - 1}{\lambda_p^2} \right) \cdot c_1 \geq 0$ $\lambda_p^2 = \lambda^2 - 0.5$ for $1 \leq \lambda_p^2 \leq 3$ $c_1 = \left( 1 - \frac{F_1}{\alpha} \right) \geq 0$ $H = \lambda - \frac{2\lambda}{c(T + \sqrt{T^2 - 4})} \geq R$ $T = \lambda + \frac{14}{15\lambda} + \frac{1}{3}$
	$0 > \Psi > -1$	$1 \leq \alpha \leq 1.5$	$K = F_1 \left[ \left( 1 + \frac{1}{\alpha^2} \right)^2 \cdot \frac{2.1(1 + \Psi)}{1.1} - \frac{\Psi}{\alpha^2} (13.9 - 10\Psi) \right]$	
		$\alpha < 1.5$	$K = F_1 \left[ \left( 1 + \frac{1}{\alpha^2} \right)^2 \cdot \frac{2.1(1 + \Psi)}{1.1} - \frac{\Psi}{\alpha^2} (5.87 + 1.87\alpha^2 + \frac{8.6}{\alpha^2} - 10\Psi) \right]$	
	$\Psi \leq -1$	$1 \leq \alpha \leq \frac{3(1 - \Psi)}{4}$	$K = F_1 \left( \frac{1 - \Psi}{\alpha} \right)^2 \cdot 5.975$	
		$\alpha > \frac{3(1 - \Psi)}{4}$	$K = F_1 \left[ \left( \frac{1 - \Psi}{\alpha} \right)^2 \cdot 3.9675 + 0.5375 \left( \frac{1 - \Psi}{\alpha} \right)^4 + 1.87 \right]$	
		$1 \geq \Psi \geq 0$	$\alpha > 0$	
$0 > \Psi \geq -1$		$K = 4 \left( 0.425 + \frac{1}{\alpha^2} \right) (1 + \Psi) - 5\Psi(1 - 3.42\Psi)$		
	$1 \geq \Psi \geq -1$	$\alpha > 0$	$K = \left( 0.425 + \frac{1}{\alpha^2} \right) \frac{3 - \Psi}{2}$	
	==	$\alpha \geq 1$	$K = K_\tau \cdot \sqrt{3}$	$\kappa_\tau = 1$ for $\lambda \leq 0.84$ $\kappa_\tau = \frac{0.84}{\lambda}$ for $\lambda > 0.84$
		$0 < \alpha < 1$	$K_\tau = \left[ 5.34 + \frac{4}{\alpha^2} \right]$	
		$0 < \alpha < 1$	$K_\tau = \left[ 4 + \frac{5.34}{\alpha^2} \right]$	
Explanations for boundary conditions: ----- plate edge free      ————— plate edge simply supported				

#### 4. Webs and face plate of primary supporting members

For non-stiffened webs and face plate of primary supporting members sufficient buckling strength as for the hatch cover top and lower plating is to be demonstrated according to **Par 3**.

#### 5. Proof of partial and total fields of hatch covers

(1) Transverse stiffeners of partial and total plate fields comply with the conditions set out in (3) through (4). For u-type stiffeners, the proof of torsional buckling strength according to (4) can be omitted. Single-side welding is not permitted to use for secondary stiffeners except for u-stiffeners.

(2) Effective width of top and lower hatch cover plating

(A) For demonstration of buckling strength according to (3) through (4) the effective width of plating may be determined by the following formulae.

(a) The effective width of plating  $a_m$  or  $b_m$  may be determined by following formulae(see also **Fig 4.2.7**). But it is not to be taken greater than the value obtained from **306**.

$$b_m = \kappa_x \cdot b \text{ for longitudinal stiffeners}$$

$$a_m = \kappa_y \cdot a \text{ for transverse stiffeners}$$

$$\kappa_x, \kappa_y = \text{reduction factor given in Table 4.2.9}$$

$$a, b = \text{according to Par 2.}$$

(b) The effective width  $e'_m$  of stiffened plates of primary supporting members may be determined as follows. The  $a_m$  and  $b_m$  are to be determined for  $\psi=1$ .

(i) For stiffening parallel to web of primary supporting member(refer **Fig 4.2.8**). But  $b$  equal to  $a$  in case of  $b \geq e_m$

$$b < e_m$$

$$e'_m = nb_m$$

$n$  = integer number of stiffener spacings  $b$  inside the effective breadth  $e_m$  according to **306**.

$$= \text{int} \left( \frac{e_m}{b} \right)$$

(ii) For stiffening perpendicular to web of primary supporting member(refer **Fig 4.2.9**). But  $a$  equal to  $b$  in case of  $a < e_m$

$$a \geq e_m$$

$$e'_m = na_m < e_m$$

$$n = 2.7 \frac{e_m}{a} \leq 1$$

$e$  = width of plating supported according to **Table 4.2.6**

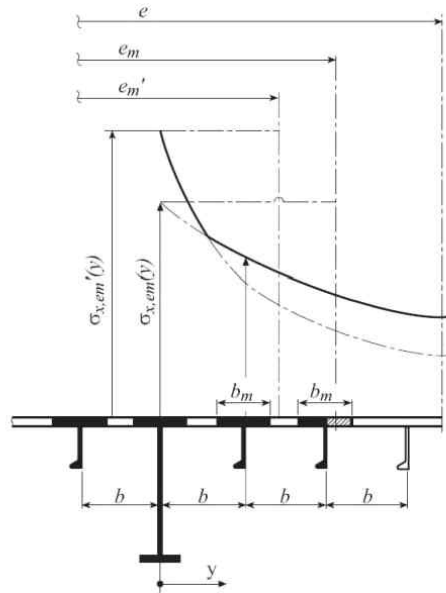


Fig 4.2.8 Stiffening parallel to web of primary supporting member

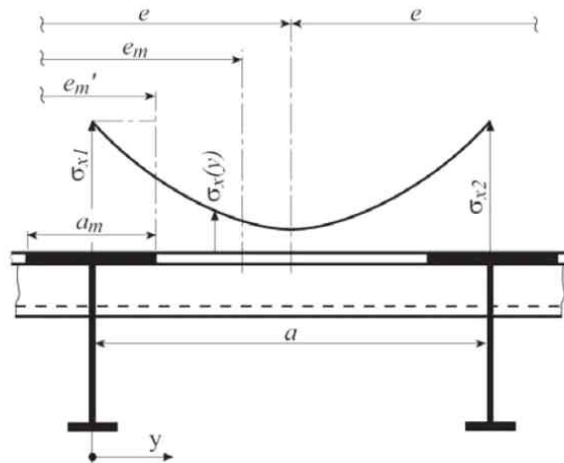


Fig 4.2.9 Stiffening perpendicular to web of primary supporting mem

- (B) Scantling of top plates and stiffeners are to be determined as follows.
- Scantling are in general to be determined according to the maximum stresses  $\sigma_x(y)$  at webs of primary supporting member and stiffeners, respectively.
  - For stiffeners with spacing  $b$  under compression arranged parallel to primary supporting members no value less than  $0.25\sigma_y$  shall be inserted for  $\sigma_x(y=b)$ .
  - The stress distribution between two primary supporting members can be obtained by the following formula:

$$\sigma_x(y) = \sigma_{x1} \cdot \left\{ 1 - \frac{y}{e} \left[ 3 + c_1 - 4 \cdot c_2 - 2 \frac{y}{e} (1 + c_1 - 2c_2) \right] \right\}$$

$$c_1 = \frac{\sigma_{x2}}{\sigma_{x1}} \quad 0 \leq c_1 \leq 1$$

$$c_2 = \frac{1.5}{e} \cdot (e''_{m1} + e''_{m2}) - 0.5$$

$e''_{m1}$  = proportionate effective breadth  $e_{m1}$  or proportionate effective width  $e'_{m1}$  of primary supporting member 1 within the distance  $e$ , as considered condition

$e''_{m2}$  = proportionate effective breadth  $e_{m2}$  or proportionate effective width  $e'_{m2}$  of primary supporting member 2 within the distance  $e$ , as considered condition

$\sigma_{x1}, \sigma_{x2}$  = normal stresses in plates of adjacent primary supporting member 1 and 2 with spacing  $e$ , based on cross-sectional properties considering the effective breadth

$y$  = distance of considered location from primary supporting member 1

(d) Shear stress distribution in the plates may be assumed linearly.

(3) Lateral buckling of stiffeners

(A) The stiffeners under lateral buckling shall be accordance with following requirements.

$$\frac{\sigma_a + \sigma_b}{\sigma_F} S \leq 1$$

$\sigma_a$  = uniformly distributed compressive stress(N/mm<sup>2</sup>) in the direction of the stiffener axis.

$\sigma_a = \sigma_x$  for longitudinal stiffeners

$\sigma_a = \sigma_y$  for transverse stiffeners

$\sigma_b$  = bending stress(N/mm<sup>2</sup>) in the stiffener with  $\sigma_x = \sigma_n, \tau = \tau_{SF}$

$$\sigma_b = \frac{M_0 + M_1}{Z_{st} 10^3}$$

$M_0$  = bending moment(Nmm) due to the deformation  $w$  of stiffener, taken equal to:

$$M_0 = F_{Ki} \frac{p_z \cdot w}{c_f - p_z} \quad \text{with } (c_f - p_z) > 0$$

$M_1$  = bending moment(Nmm) due to the lateral load  $p$  equal to follows.  $n$  is to be taken equal to 1 for transverse stiffeners.

$$M_1 = \frac{P b a^2}{24 \times 10^3} \quad \text{for longitudinal stiffeners}$$

$$M_1 = \frac{P a (nb)^2}{8 c_s \times 10^3} \quad \text{for transverse stiffeners}$$

$P$  = lateral load(kN/m<sup>2</sup>)

$F_{Ki}$  = ideal buckling force(N) of the stiffener

$$F_{Ki x} = \frac{\pi^2}{a^2} E I_x 10^4 \quad (\text{N}) \quad \text{for longitudinal stiffeners}$$

$$F_{Ki y} = \frac{\pi^2}{(nb)^2} E I_y 10^4 \quad (\text{N}) \quad \text{for transverse stiffeners}$$

$I_x, I_y$  = net moments of inertia(cm<sup>4</sup>) of the longitudinal or transverse stiffener including effective width of attached plating according to 307. 5. (2).  $I_x$  and  $I_y$  are to comply with the following criteria:

$$I_x \geq \frac{b t^3}{12 \times 10^4}$$

$$I_y \geq \frac{a t^3}{12 \times 10^4}$$

$P_z$  = nominal lateral load(N/mm<sup>2</sup>) of the stiffener due to  $\sigma_x$ ,  $\sigma_y$  and  $\tau$

$$p_{zx} = \frac{t}{b} \left( \sigma_{xl} \left( \frac{\pi b}{a} \right)^2 + 2c_y \sigma_y + \sqrt{2} \tau_1 \right) \text{ for longitudinal stiffeners}$$

$$p_{zy} = \frac{t}{a} \left( 2c_x \sigma_{xl} + \sigma_y \left( \frac{\pi a}{nb} \right)^2 \left( 1 + \frac{A_y}{at} \right) + \sqrt{2} \tau_1 \right) \text{ for transverse stiffeners}$$

$$\sigma_{xl} = \sigma_x \left( 1 + \frac{A_x}{bt} \right)$$

$c_x, c_y$  = factor taking into account the stresses perpendicular to the stiffener's axis and distributed variable along the stiffener's length

$$= 0.5(1 + \Psi) \text{ for } 0 \leq \Psi \leq 1$$

$$= \frac{0.5}{1 - \Psi} \text{ for } \Psi < 0$$

$A_x, A_y$  = net sectional area(mm<sup>2</sup>) of the longitudinal or transverse stiffener, respectively, without attached plating

$$\tau_1 = \left[ \tau - t \sqrt{\sigma_F \cdot E \left( \frac{m_1}{a^2} + \frac{m_2}{b^2} \right)} \right] \geq 0 \text{ for longitudinal stiffeners:}$$

$$\frac{a}{b} \geq 2.0 \quad : \quad m_1 = 1.47 \quad m_2 = 0.49$$

$$\frac{a}{b} < 2.0 \quad : \quad m_1 = 1.96 \quad m_2 = 0.37 \text{ for transverse stiffeners:}$$

$$\frac{a}{n \cdot b} \geq 0.5 \quad : \quad m_1 = 0.37 \quad m_2 = \frac{1.96}{n^2}$$

$$\frac{a}{n \cdot b} < 0.5 \quad : \quad m_1 = 0.49 \quad m_2 = \frac{1.47}{n^2}$$

$$w = w_0 + w_1$$

$w_0$  = assumed imperfection(mm). For stiffeners sniped at both ends  $w_0$  must not be taken less than the distance from the midpoint of plating to the neutral axis of the profile including effective width of plating.

$$w_0 \leq \min \left( \frac{a}{250}, \frac{b}{250}, 10 \right) \text{ for longitudinal stiffeners}$$

$$w_0 \leq \min \left( \frac{a}{250}, \frac{nb}{250}, 10 \right) \text{ for transverse stiffeners}$$

$w_1$  = Deformation of stiffener(mm) at midpoint of stiffener span due to lateral load  $P$ .

In case of uniformly distributed load the following values for  $w_1$  may be used:

$$w_1 = \frac{Pb^4}{384 \times 10^7 \times EI_x} \text{ for longitudinal stiffeners}$$

$$w_1 = \frac{5Pa(nb)^4}{384 \times 10^7 \times EI_y c_s^2} \text{ for transverse stiffeners}$$

$c_f$  = elastic support provided by the stiffener(N/mm<sup>2</sup>)

- For longitudinal stiffeners:

$$c_{fx} = F_{Kix} \cdot \frac{\pi^2}{a^2} \cdot (1 + c_{px})$$

$$c_{px} = \frac{1}{1 + \frac{0.91 \cdot \left( \frac{12 \cdot 10^4 \cdot I_x}{t^3 \cdot b} - 1 \right)}{c_{xa}}}$$

$$c_{xa} = \left[ \frac{a}{2b} + \frac{2b}{a} \right]^2 \text{ for } a \geq 2b$$

$$c_{xa} = \left[ 1 + \left( \frac{a}{2b} \right)^2 \right]^2 \text{ for } a < 2b$$

- For transverse stiffeners:

$$c_{fy} = c_s \cdot F_{Ky} \cdot \frac{\pi^2}{(n \cdot b)^2} \cdot (1 + c_{py})$$

$$c_{py} = \frac{1}{1 + \frac{0.91 \cdot \left( \frac{12 \cdot 10^4 \cdot I_y}{t^3 \cdot a} - 1 \right)}{c_{ya}}}$$

$$c_{ya} = \left[ \frac{n \cdot b}{2a} + \frac{2a}{n \cdot b} \right]^2 \text{ for } n \cdot b \geq 2a$$

$$c_{ya} = \left[ 1 + \left( \frac{n \cdot b}{2a} \right)^2 \right]^2 \text{ for } n \cdot b < 2a$$

$c_s$  = factor accounting for the boundary conditions of the transverse stiffener

= 1,0 for simply supported stiffeners

= 2,0 for partially constraint stiffeners

$Z_{st}$  = net section modulus of stiffener (long. or transverse) (cm<sup>3</sup>) including effective width of plating according to (2)

(B) If no lateral load  $p$  is acting the bending stress  $\sigma_b$  is to be calculated at the midpoint of the stiffener span for that fibre which results in the largest stress value.

(C) If a lateral load  $p$  is acting, the stress calculation is to be carried out for both fibres of the stiffener's cross sectional area (if necessary for the biaxial stress field at the plating side).

(4) Torsional buckling of stiffeners

(A) Longitudinal stiffeners

The longitudinal stiffeners are to comply with the following criteria:

$$\frac{\sigma_x \cdot S}{\kappa_T \cdot \sigma_F} \leq 1.0$$

$\kappa_T$  = coefficient taken equal to:

$$\kappa_T = 1.0 \text{ for } \lambda_T \leq 0.2$$

$$\kappa_T = \frac{1}{\Phi + \sqrt{\Phi^2 - \lambda_T^2}} \text{ for } \lambda_T > 0.2$$

$$\Phi = 0.5(1 + 0.21(\lambda_T - 0.2) + \lambda_T^2)$$

$\lambda_T$  = reference degree of slenderness taken equal to:

$$\lambda_T = \sqrt{\frac{\sigma_F}{\sigma_{\kappa T}}}$$

$$\sigma_{\kappa T} = \frac{E}{I_p} \left( \frac{\pi^2 \cdot I_w \cdot 10^2}{a^2} \varepsilon + 0.385 \cdot I_T \right) \text{ (N/mm}^2\text{)}$$

$I_p$  = net polar moment of inertia of the stiffener(cm<sup>4</sup>) related to the point C of **Fig 4.2.10.** (see **Table 4.2.10**)

$I_T$  = net St. Venant's moment of inertia of the stiffener( $\text{cm}^4$ ) (see Table 4.2.10)

$I_w$  = net sectorial moment of inertia of the stiffener( $\text{cm}^6$ ) related to the point C of Fig 4.2.10. (see Table 4.2.10)

$\varepsilon$  = degree of fixation taken equal to:

$$\varepsilon = 1 + 10^{-3} \sqrt{\frac{a^4}{\frac{3}{4}\pi^4 \cdot I_w (b/t^3 + 4h_w/3t_w^3)}}$$

$h_w$  = web height

$t_w$  = net web thickness( $\text{cm}^4$ )

$b_f$  = flange breadth( $\text{cm}^4$ )

$t_f$  = net flange thickness( $\text{cm}^4$ )

$A_w$  = net web area equal to:  $A_w = h_w \cdot t_w$

$A_f$  = net flange area equal to:  $A_f = b_f \cdot t_f$

$e_f = h_w + \frac{t_f}{2}$  (mm)

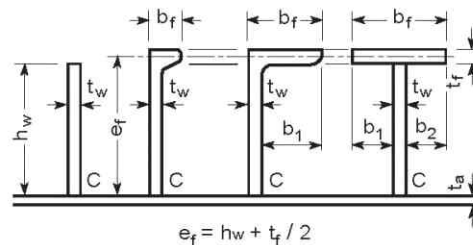


Fig 4.2.10 Dimensions of stiffener

Table 4.2.10 Moments of inertia

Section	$I_p$	$I_T$	$I_w$
Flat bar	$\frac{h_w^3 \cdot t_w}{3 \cdot 10^4}$	$\frac{h_w \cdot t_w^3}{3 \cdot 10^4} \left(1 - 0.63 \frac{t_w}{h_w}\right)$	$\frac{h_w^3 \cdot t_w^3}{36 \cdot 10^6}$
Sections with bulb or flange	$\left(\frac{A_w \cdot h_w^2}{3} + A_f \cdot e_f^2\right) 10^{-4}$	$\frac{h_w \cdot t_w^3}{3 \cdot 10^4} \left(1 - 0.63 \frac{t_w}{h_w}\right) + \frac{b_f \cdot t_f^3}{3 \cdot 10^4} \left(1 - 0.63 \frac{t_f}{b_f}\right)$	for bulb and angle sections: $\frac{A_f \cdot e_f^2 \cdot b_f^2}{12 \cdot 10^6} \left(\frac{A_f + 2.6 A_w}{A_f + A_w}\right)$ for tee-sections: $\frac{b_f^3 \cdot t_f \cdot e_f^2}{12 \cdot 10^6}$

(B) Transverse stiffeners

For transverse stiffeners loaded by compressive stresses and which are not supported by longitudinal stiffeners, sufficient torsional buckling strength is to be demonstrated analogously in accordance with (A).

## Section 4 Hatch Coamings strength criteria

### 401. General

1. The stiffeners of the hatch coamings are to be continuous over the breadth and length of the hatch coamings.
2. Coamings are to be stiffened on their upper edges with a stiffener suitably shaped to fit the hatch cover closing appliances. Moreover, when covers are fitted with tarpaulins, an angle or a bulb section is to be fitted all around coamings of more than 3 m in length or 600 mm in height; this stiffener is to be fitted at approximately 250 mm below the upper edge. The width of the horizontal flange of the angle is not to be less than 180 mm.
3. Where hatch covers are fitted with tarpaulins, coamings are to be strengthened by brackets or stays with a spacing not greater than 3 m. Where the height of the coaming exceeds 900 mm, additional strengthening may be required. However, reductions may be granted for protected transverse coamings.
4. When two hatches are close to each other, underdeck stiffeners are to be fitted to connect the longitudinal coamings with a view to maintaining the continuity of their strength. Similar stiffening is to be provided over 2 frame spacings at ends of hatches exceeding 9 frame spacings in length.
5. Where watertight metallic hatch covers are fitted, other arrangements of equivalent strength may be adopted.
6. Construction and scantling of hatchway coaming for deep tanks are also to comply with the requirements of **Pt 3, Ch 15** of the Rules.

### 402. Net plate thickness of coamings

1. The net thickness of weather deck hatch coamings shall not be less than the larger of the following values and longitudinal strength aspects are to be observed.

$$t = 14.2S \sqrt{\frac{P_H}{0.95\sigma_y}} \quad (\text{mm})$$

$$t = 6 + \frac{L}{100} \quad (\text{mm})$$

$S$  = stiffener spacing (m)

$L$  = length of ship (m), need not be taken greater than 300 m

$P_H$  = horizontal weather load according to **203**.

$\sigma_y$  = minimum yield stress(N/mm<sup>2</sup>) of the material

2. The gross thickness of the coaming plate at the sniped stiffener end shall not be less than

$$t = 19.6 \sqrt{\frac{P_H S (l - 0.5S)}{\sigma_y}} \quad (\text{mm})$$

$l$  = secondary stiffener span, in m, to be taken as the spacing of coaming stays

$S, P_H, \sigma_y$  = according to **Par 1**

### 403. Net scantling of stiffeners of coamings

1. For stiffeners with both ends constraint the net section modulus  $Z$  and net shear area  $A$  calculated on the basis of net thickness, must not be less than:

$$Z = \frac{83}{\sigma_y} P_H S l^2 \quad (\text{cm}^3)$$

$$A = \frac{10 P_H S l}{\sigma_y} \quad (\text{cm}^2)$$

$P_H, l, S, \sigma_y =$  according to **402**.

2. For sniped stiffeners at coaming corners section modulus and shear area have to be 1.35 times of the value determined by **Par 1**.
3. Horizontal stiffeners on hatch coamings, which are part of the longitudinal hull structure are to be have net thickness deducted by corrosion additions specified in **Table 4.2.1** and to be accordance with buckling strength specified in **Pt 3, Ch 3, 403. 2** of the Rules.

#### **404. Coaming stays**

##### **1. Coaming stay section modulus**

- (1) The net section modulus  $Z$  of coaming stays at the connection with deck shall not be less than:

$$Z = \frac{526}{\sigma_y} e h_s^2 p_A \quad (\text{cm}^3)$$

$h_s, e =$  height and spacing of coaming stays (m)

$P_H, \sigma_y =$  according to **202**.

- (2) For other designs of coaming stays, such as those shown in **Fig. 4.2.11** (c), (d), the stresses are to be determined through a grillage analysis or FEM. The calculated stresses are to be less than the permissible stresses according to **302. 1**.
- (3) Coaming stays are to be supported by appropriate substructures. Face plates may only be included in the calculation if an appropriate substructure is provided and welding provides an adequate joint.

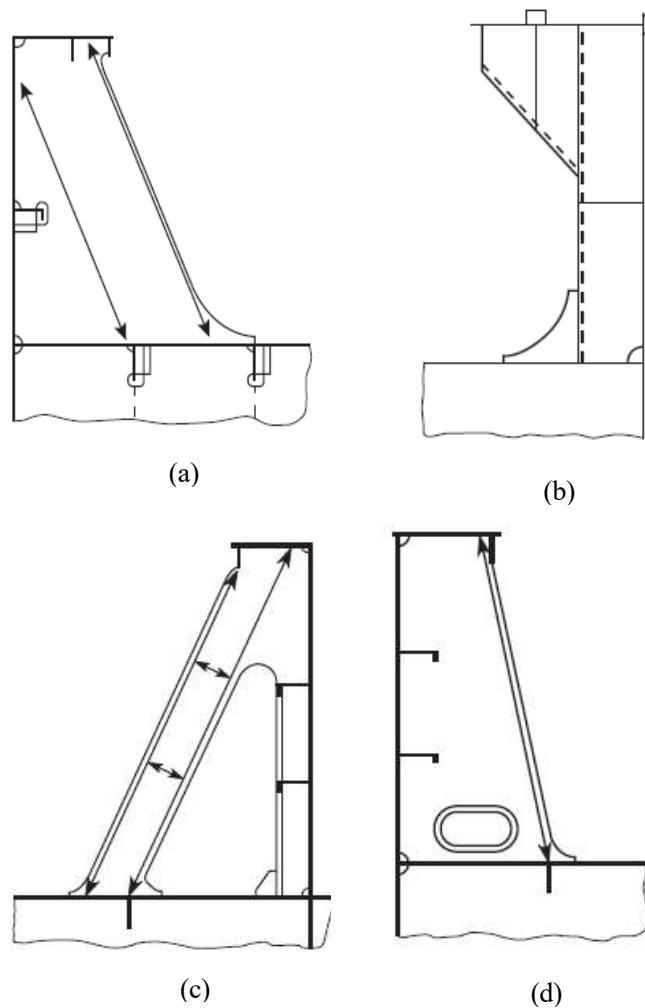


Fig 4.2.11 Examples of coaming stays

## 2. Web thickness of coaming stays

Web gross thickness at the connection with deck shall not be less than:

$$t_W = \frac{2 e h_S P_H}{\sigma_y h_W}$$

$h_W$  = web height of coaming stay at its lower end (m)

$h_S, e, P_H, \sigma_y$  = corrosion addition (mm) according to **Par 1**.

## 3. Coaming stays under friction load

For coaming stays, which transfer friction forces at hatch cover supports, sufficient fatigue strength is to be considered according to Society, refer to **507. 2**.

## 405. Further requirements for hatch coamings

### 1. Longitudinal strength

(1) Hatch coamings which are part of the longitudinal hull structure are to be designed according to the requirements for longitudinal strength of **Pt 3, Ch 3** of the Rules.

- (2) For structural members welded to coamings and for cutouts in the top of coamings sufficient fatigue strength is to be verified.
- (3) Longitudinal hatch coamings with a length exceeding  $0.1 \cdot L$  m are to be provided with tapered brackets or equivalent transitions and a corresponding substructure at both ends. At the end of the brackets they are to be connected to the deck by full penetration welds of minimum 300 mm in length.

## 2. Local details

- (1) The design of local details is to comply with the requirements in this section for the purpose of transferring the pressures on the hatch covers to the hatch coamings and, through them, to the deck structures below.
- (2) Hatch coamings and supporting structures are to be adequately stiffened to accommodate the loading from hatch covers, in longitudinal, transverse and vertical directions.
- (3) The normal stress  $\sigma$  and the shear stress  $\tau$  ( $\text{N}/\text{mm}^2$ ) induced in the underdeck structures by the loads transmitted by stays are to comply with the following formulae :

$$\sigma \leq 0.95\sigma_y$$

$$\tau \leq 0.5\sigma_y$$

- (4) Unless otherwise stated, weld connections and materials are to be dimensioned and selected in accordance with **Pt 2** and **Pt 3, Ch 1, Sec 4, 5**.
- (5) Double continuous fillet welding is to be adopted for the connections of stay webs with deck plating and the weld throat thickness is to be not less than  $0.44 t_W$ , where  $t_W$  is the gross thickness of the stay web.

## 3. Stays

On ships carrying cargo on hatch cover, such as timber, coal or coke, the stays are to be spaced not more than 1.5 m apart.

## 4. Extend of coaming plates

Coaming plates are to extend to the lower edge of the deck beams or hatch side girders are to be fitted that extend to the lower edge of the deck beams. Extended coaming plates and hatch side girders are to be flanged or fitted with face bars or half-round bars. **Fig.4.2.12** gives an example.

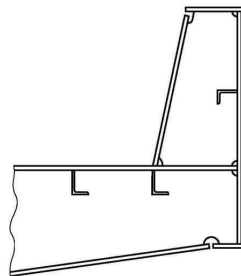


Fig 4.2.12 Example for the extend of coaming plates

## 5. Coamings of small hatchways

The coaming plate thickness is to be accordance with the following and small hatchways means having opening area less than  $1.5\text{m}^2$ .

$$L < 100 \text{ m} \quad : \quad 4 + 0.05L \text{ (mm)}$$

$$L \geq 100 \text{ m} \quad : \quad 9.0 \text{ (mm)}$$

Coamings are to be suitably strengthened where their height exceeds 0.8 m or their greatest horizontal dimension exceeds 1.2 m, unless their shape ensures an adequate rigidity.

## Section 5 Hatch cover details - Closing Arrangement, Securing Devices and Stoppers

### 501. Weathertightness

1. Where the hatchway is exposed, the weathertightness is to be ensured by gaskets and clamping devices sufficient in number and quality.
2. Weathertightness may also be ensured means of tarpaulins is granted by the Administration.

### 502. General

1. Panel hatch covers are to be secured by appropriate devices (bolts, wedges or similar) suitably spaced alongside the coamings and between cover elements. The securing and stop arrangements are to be fitted using appropriate means which cannot be easily removed.
2. In addition to the requirements above, all hatch covers, and in particular those carrying deck cargo, are to be effectively secured against horizontal shifting due to the horizontal forces resulting from ship motions.
3. Towards the ends of the ship, vertical acceleration forces may exceed the gravity force. The resulting lifting forces are to be considered when dimensioning the securing devices according to **504**.
4. Hatch coamings and supporting structure are to be adequately stiffened to accommodate the loading from hatch covers.
5. Hatch covers provided with special sealing devices, insulated hatch covers, flush hatch covers and those having coamings of a reduced height (see **103**.) are considered by the Society on a case by case basis. **[See Guidance]**
6. In the case of hatch covers carrying containers, the scantlings of the closing devices are to take into account the possible upward vertical forces transmitted by the containers.

### 503. Gaskets

1. The weight of hatch covers and any cargo stowed thereon, together with inertia forces generated by ship motions, are to be transmitted to the ship's structure through steel to steel contact. This may be achieved by continuous steel to steel contact of the hatch cover skirt plate with the ship's structure or by means of defined bearing pads.
2. The sealing is to be obtained by a continuous gasket of relatively soft elastic material compressed to achieve the necessary weathertightness. Similar sealing is to be arranged between cross-joint elements.
3. Where fitted, compression flat bars or angles are to be well rounded where in contact with the gasket and to be made of a corrosion-resistant material.
4. The gasket and the securing arrangements are to maintain their efficiency when subjected to large relative movements between the hatch cover and the ship's structure or between hatch cover elements. If necessary, suitable devices are to be fitted to limit such movements.
5. The gasket material is to be of a quality suitable for all environmental conditions likely to be encountered by the ship, and is to be compatible with the cargoes transported.
6. The material and form of gasket selected are to be considered in conjunction with the type of hatch cover, the securing arrangement and the expected relative movement between the hatch cover and the ship's structure.
7. The gasket is to be effectively secured to the hatch cover.
8. Coamings and steel parts of hatch covers in contact with gaskets are to have no sharp edges.
9. Metallic contact is required for an earthing connection between the hatch cover and the hull structures.

### 10. Exemption of gaskets

In case of container ship accordance with the following requirements, gaskets may be omitted and clamping devices for steel hatchway covers may be suitably dispensed.

- (1) The hatchway coamings should be not less than 600 mm in height.
- (2) The exposed deck on which the hatch covers are located is situated above a depth  $H(x)$ .  $H(x)$  is to be shown to comply with the following criteria:

$$H(x) \geq T_{fp} + f_b + h'_{N} \quad (\text{m})$$

$T_{fp}$  = draught, in m, corresponding to the assigned summer load line

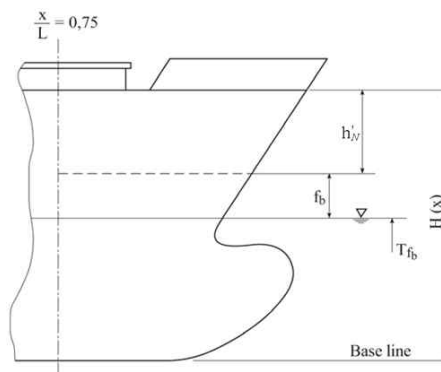
$f_b$  = minimum required freeboard, in m, determined in accordance with **ICLL**

**Reg. 28** as modified by further regulations as applicable

$$h'_{N} = 4.6 \text{ m for } \frac{x}{L_{LL}} \leq 0,75$$

$$= 6.9 \text{ m for } \frac{x}{L_{LL}} > 0,75$$

- (3) The non-weathertight gaps between hatch cover panels should be considered as unprotected openings with respect to the requirements of intact and damage stability calculations. They should be as small as possible commensurate with the capacity of the bilge system and expected water ingress, and the capacity and operational effectiveness of the fire-fighting system and, generally, should not exceed 50 mm.
- (4) Labyrinths, gutter bars, or equivalents should be fitted proximate to the edges panel in way of the gaps to minimize the amount of water that can enter the container hold from the top surface of each panel. In general, the height of such means is not to be less than 65mm from the top of the coaming and gutter bars or from the top of the panel, and the gaps between hatch cover and the top of the coaming are not to exceed 10mm(See **Fig 4.2.14**)
- (5) The gaps between pannels are to be less than 50mm where the hatch cover has several pannels.
- (6) Bilge alarms should be provided in each hold fitted with non-weathertight cover.
- (7) The requirements of MSC/Circ.1087 was applied when carry dangerous goods. **Fig 4.2.13 Definition of  $H(x)$**



**Fig 4.2.13 Definition of  $H(x)$**

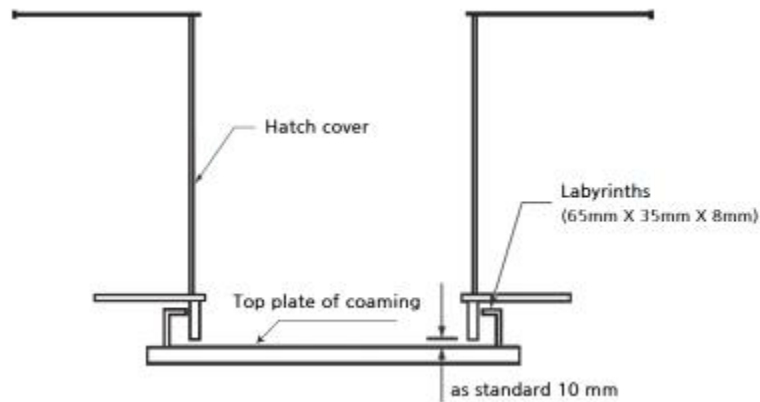


Fig 4.2.14 Example of Labyrinths

## 504. Clamping devices

### 1. Arrangements

- (1) The clamping and stopping devices are to be arranged so as to ensure sufficient compression on gaskets between hatch covers and coamings and between adjacent hatch covers.
- (2) Arrangement and spacing are to be determined with due attention to the effectiveness for weathertightness, depending on the type and the size of the hatch cover, as well as on the stiffness of the hatch cover edges between the clamping devices.
- (3) At cross-joints of multipanel covers, (male/female) vertical guides are to be fitted to prevent excessive relative vertical deflections between loaded/unloaded panels.
- (4) The location of stoppers is to be compatible with the relative movements between hatch covers and the ship's structure in order to prevent damage to them. The number of stoppers is to be as small as possible.

### 2. Spacing

The spacing of the clamping devices is to be generally not greater than 6 m.

### 3. Construction

- (1) Clamping devices with reduced scantlings may be accepted provided it can be demonstrated that the possibility of water reaching the deck is negligible.
- (2) Clamping devices are to be of reliable construction and securely attached to the hatchway coamings, decks or hatch covers.
- (3) Individual clamping devices on same hatch cover are to have approximately the same stiffness characteristics.
- (4) Where rod cleats are fitted, resilient washers or cushions are to be incorporated.
- (5) Where hydraulic cleating is adopted, a positive means is to be provided so that it remains mechanically locked in the closed position in the event of failure of the hydraulic system.

### 4. Area of securing devices

- (1) The gross cross-sectional area of the clamping devices is not to be less than. Rods or bolts are to have a gross diameter not less than 19 mm for hatchways exceeding 5 m<sup>2</sup> in area.

$$A = 0.28 q S_{SD} k_i \quad (\text{cm}^2)$$

$q$  = packing line pressure (N/mm), minimum 5 N/mm

$S_{SD}$  = spacing between securing devices (m), not to be taken less than 2 m

$k_i$  =  $(235/\sigma_y)^e$

$\sigma_y$  = minimum yield strength of the material (N/mm<sup>2</sup>) but is not to be taken greater than  $0.7\sigma_T$ , where  $\sigma_T$  is the tensile strength of the material (N/mm<sup>2</sup>).

$$e = 0.75 \text{ for } \sigma_Y > 235 \text{ N/mm}^2$$

$$= 1.00 \text{ for } \sigma_Y \leq 235 \text{ N/mm}^2$$

- (2) Clamping devices of special design in which significant bending or shear stresses occur may be designed as anti-lifting devices according to 506. and the load shall be obtained from the following formulae.

$$P = q \times S_{SD} \quad (kN)$$

$q, S_{SD} = \text{according to (1)}$

### 505. Stoppers

1. For the design of the stopper against shifting the horizontal mass forces  $F=ma$  are to be calculated with the following accelerations. The accelerations in longitudinal direction and in transverse direction do not need to be considered as acting simultaneously.

$$a_x = 0.2g \text{ in longitudinal direction}$$

$$a_y = 0.5g \text{ in transverse direction}$$

$$m = \text{Sum of mass of cargo lashed on the hatch cover and mass of hatch cover}$$

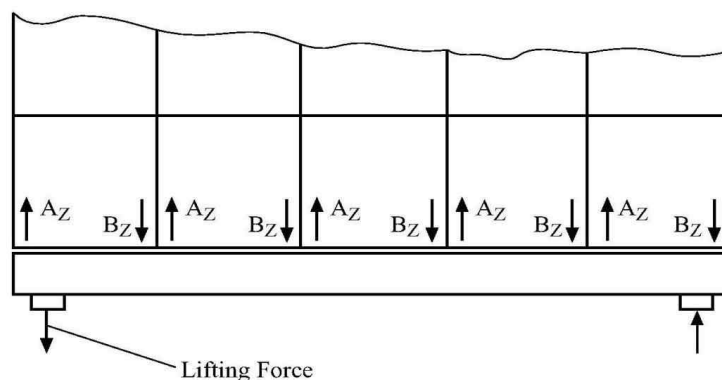
2. The greater of the design loads resulting from **203.** and **Par 1** is to be applied for the dimensioning of the stoppers and their substructures. But the permissible stress in stoppers and their substructures, in the cover, and of the coamings is to be determined according to **302. 1**
3. Arrangement of stoppers are accordance with the provisions in **704. 2** are to be observed and are to be considered the requirements in **507.**

### 506. Anti lifting devices

1. When cargo is loaded on hatch covers, the securing devices are to be provided for anti lifting by the lifting forces resulting from loads according to **205.**, refer **Fig 4.2.15.**
2. Under these loadings of **Par 1** the equivalent stress in the anti lifting devices is not to exceed:

$$\sigma_E = 150/k_l \quad (\text{N/mm}^2)$$

$$k_l = \text{according to } \mathbf{504. 4 (1)}$$



**Fig 4.2.15 Lifting forces at a hatch cover**

3. Anti lifting devices are to be omitted in the case in which the height  $h_E$ (mm) of the transverse cover guides is not less than that obtained from the following formula but shall be not less than the height of skirt plate + 150mm.(See **Fig 4.2.16**)

$$h_E = 1.75 \sqrt{(2se + d^2)} - 0.75d$$

- $e$  = Largest distance(mm) from the inner edges of the transverse cover guides to the ends of the cover edge plate
- $s$  = Total clearance(mm),  $10 \leq s \leq 40$
- $d$  = Distance between the upper edge of transverse stopper and the hatch cover supports

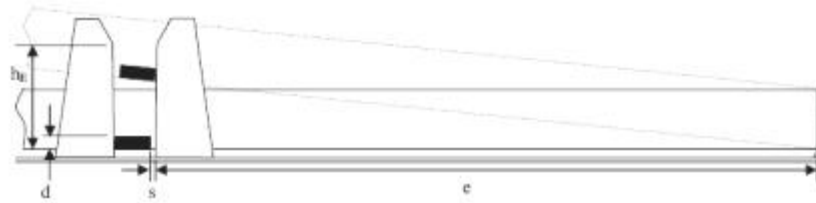


Fig 4.2.16 Height of transverse cover guides

**507. Hatch cover supports**

1. For the transmission of the support forces resulting from the load cases specified in **Sec. 2** and of the horizontal mass forces specified in **505. 1**, supports are to be provided which are to be designed such that the nominal surface pressures in general do not exceed the following values:

$p_{nmax} = dp_n$  (N/mm<sup>2</sup>), But for metallic supporting surfaces not subjected to relative displacements the nominal surface pressure applies  $p_{nmax} = 3p_n$  (N/mm<sup>2</sup>)

$d = 3.75 - 0.015L$

$d_{max} = 3.0$

$d_{min} = 1.0$  in general

$= 2.0$  for partial loading conditions

$p_n$  = see **Table 4.2.11**

2. Where large relative displacements of the supporting surfaces are to be expected, the use of material having low wear and frictional properties is recommended.
3. Drawings of the supports must be submitted. In the drawings of supports the permitted maximum pressure given by the material manufacturer must be specified.

**Table 4.2.11 Permissible nominal surface pressure  $p_n$  (2019)**

Support material	$p_n$ (N/mm <sup>2</sup> ) when loaded by	
	Vertical force	Horizontal force (on stoppers)
Hull structural steel	25	40
Hardened steel	35	50
Lower friction materials	50	-

4. The substructures of the supports must be of such a design, that a uniform pressure distribution is achieved.
5. Irrespective of the arrangement of anti lifting devices, the supports must be able to transmit the following force  $F$  in the longitudinal and transverse direction:

$$F = \mu \frac{P_V}{\sqrt{d}}$$

$P_V$  = vertical supporting force on related supports

$\mu$  = frictional coefficient, the value equal to 0.5 in general, For non-metallic, low-friction support materials on steel, the friction coefficient may be reduced but not to be less than 0.35 and to the satisfaction of the Society.

$d$  = according to **Par 1**

6. Supports as well as the adjacent structures and substructures are to be designed such that the permissible stresses according to **302. 1** are not exceeded.
7. For substructures and adjacent structures of supports subjected to horizontal forces  $P_h$ , a fatigue strength analysis is to be considered.

### **508. Container foundations on hatch covers**

The substructures of container foundations are to be designed for cargo and container loads according to **Sec 2**, applying the permissible stresses according to **302. 1**.

### **509. Drainage**

1. Drain channels are provided inside the line of gasket by means of a gutter bar or vertical extension of the hatch side and end coaming, drain openings are to be provided at appropriate positions of the drain channels.
2. Drain openings in hatch coamings are to be arranged with sufficient distance to areas of stress concentration (e.g. hatch corners, transitions to crane posts).
3. Drain openings are to be arranged at the ends of drain channels and are to be provided with efficient means for preventing ingress of water from outside, such as non-return valves or equivalent. It is unacceptable to connect fire hoses to the drain openings for this purpose.
4. Cross-joints of multi-panel covers are to be provided with drainage of water from the space above the gasket and a drainage channel below the gasket.
5. If a continuous outer steel contact is arranged between the cover and the ship's structure, drainage from the space between the steel contact and the gasket is also to be provided.

## **Section 6 Hatch ways closed by Portable Hatch Cover and weathertightened by Tarpaulins and Battens**

### **601. Application**

The requirements of this section apply to hatch covers of **ICLL Annex B Reg 15** was provided on exposed deck with approval of Administration according to **ICLL Annex B Reg 14**.

### **602. Hatch Covers**

1. The width of each supporting surface for hatch covers shall be at least 65 mm and shall be inclined as necessary to complete close.
2. For steel portable beam of **604.** and steel pontoon cover of **605.** according to the requirement of this section shall be designed with consider the design loads and allowable stress as following and shall be accordance with (3).
  - (1) The design loads  $P$  are defined in **Table 4.2.12**

Table 4.2.12 Design loads  $P$

$L_f$	Position 1	Position 2
$L_f = 24.0 \text{ m}$	19.6 kN/m <sup>2</sup>	14.7 kN/m <sup>2</sup>
$L_f \geq 100.0 \text{ m}$	34.3 kN/m <sup>2</sup>	25.5 kN/m <sup>2</sup>
In cases, $L_f$ at intermediate lengths shall be obtained by liner interpolation.		

(2) The allowable stress are to be accordance with following formulae.

$$\sigma_a = 0.68\sigma_y \text{ (N/mm}^2\text{)}$$

$$\sigma_y = \text{minimum yield strength of the material (N/mm}^2\text{)}$$

(3) The deflection  $\delta$  of portable beams and pontoon covers shall be less than the value obtained from following formulae.

$$\delta = 0.0044l_g \text{ (m)}$$

$$l_g = \text{longest span of spans between supporting point of primary stiffener.}$$

### 603. Hatch Covers

1. Where covers are made of wood, the thickness shall be at least 60 mm in association with a span of not more than 1.5 m.
2. The proper hand grip for hatch covers are to be provided according to weight, size of hatch covers except if structural unnecessary.
3. Hatch covers are to be clearly marked to indicate the deck, hatchway and position to which they belong.
4. The wood for hatchway covers is to be of good quality, straight grained and reasonably free from knots, sap and shakes.
5. The ends of all wood covers are to be protected by encircling steel band.

### 604. Portable beams

1. Carriers and sockets for portable beams for support to hatch covers are to be of substantial construction, having a minimum beaming surface of 75 mm, and are to be provided with means for efficient fitting and securing of the beams.
2. Coamings are to be stiffened in way of carriers and sockets by providing stiffeners from these fittings to the deck or equivalent strengthening.
3. Where sliding type of beams is used, the arrangement is to ensure that the beams remain properly in position where the hatchway is closed.
4. The depth of portable beams and the width of their face plates are to be suitable to ensure lateral stability of the beams. The depth of beams at their ends is not to be less than 0.4 times the depth at mid-span or 150 mm, whichever is greater.
5. Carriers or sockets for portable beams shall be of substantial construction, and shall provide means for the efficient fitting and securing of the beams. Where rolling types of beams are used, the arrangements shall ensure that the beams remain properly in position when the hatchway is closed.
6. The upper face plates of portable beams are to extend to the extreme ends of the beams. The web plates, for at least 180 mm at each ends, are to be increased in thickness to at least twice that at mid-span or to be reinforced with doubling plates.
7. Portable beams are to be provided with suitable gear for lifting on and off without getting upon them.
8. Portable beams are to be clearly marked to indicate the deck, hatchway and position to which they belong.

### **605. Steel pontoon cover**

1. The depth of steel pontoon covers at supports is not to be less than one-third the depth at mid-span or 150 mm, whichever is greater.
2. The width of bearing surface for steel pontoon covers is not to be less than 75 mm.
3. Steel pontoon covers are to be clearly marked to indicate the deck, hatchway and position to which they belong.

### **606. Tarpaulins and securing arrangements for hatchway closed by portable covers**

#### **1. Tarpaulins**

At least two layers of tarpaulins complying with the requirements in **Ch 8, Sec 7** are to be provided for each exposed hatchway on the freeboard or superstructure decks and at least one layer of such tarpaulin is to be provided for each exposed hatchway elsewhere.

#### **2. Wedges**

Wedges are to be of tough wood, generally not more than 200 mm in length and 50 mm in width. They are generally to be tapered not more than 1 : 6 and their thickness of fore end is to be not less than 13 mm.

#### **3. Battens**

Battens are to be efficient for securing the tarpaulins and not to be less than 65 mm in width and 9 mm in thickness.

#### **4. Cleats**

Cleats are to be set to fit the taper of the wedges. They are to be at least 65 mm wide and to be spaced not more than 600 mm from centre to centre. The cleats along each side are to be arranged not more than 150 mm apart from the hatch corners.

#### **5. Securing of hatch covers**

- (1) For all hatches in exposed decks and superstructures steel bars or equivalent means shall be provided in order efficiently and independently to secure each section of hatch covers after tarpaulins are battened down. Hatch covers of more than 1.5 m in length shall be secured by at least two securing appliances.
- (2) At all other hatchways in exposed on weather decks, ring bolts or other suitable fittings for lashing are to be provided.

## **Section 7 Miscellaneous Openings**

### **701. Protection of machinery space openings**

1. Machinery space openings are to be efficiently enclosed by steel casings.
2. Access openings in the machinery spaces are to be provided with steel doors and to be located in enclosed positions as far as possible. Access openings above freeboard deck not within an enclosed superstructure are to be provided with doors capable of being closed and secured from both sides. Access openings in such casings on exposed freeboard decks shall be fitted with doors complying with **Pt 3, Ch 16, 301.** of the Rules.
3. The sills of which shall be at least 600 mm above the deck if in position 1, and at least 380 mm above the deck if in position 2.
4. For ships assigned deducted freeboards, access openings of casting of machinery spaces on freeboard decks or sunken poop decks are to be guided to spaces or passages with equivalent strength of such casting and are to be segregated by double doors with inner sill height shall be not less than 230 mm.

## 702. Companionways and Miscellaneous Openings [See Guidance]

### 1. Manhole and flush scuttles

Manholes and flush scuttles in position 1 or 2 or within superstructures other than enclosed superstructures shall be closed by substantial covers capable of being made watertight. Unless secured by closely spaced bolts, the covers shall be permanently attached.

### 2. Companionways

- (1) Openings in freeboard decks other than hatchways, machinery space openings, manholes and flush scuttles shall be protected by an enclosed superstructure, or by a deckhouse or companionway of equivalent strength and weathertightness.
- (2) Any such opening in an exposed superstructure deck, in the top of a deckhouse on the freeboard deck which gives access to a space below the freeboard deck or a space within an enclosed superstructure shall be protected by an efficient deckhouse or companionway.
- (3) Doorways in such companionways or deckhouses of (1), (2) shall be fitted with doors in accordance with **Pt 3, Ch 16, 301**.
- (4) In position 1 the height of sills to the doorways in companionways of (1) to (3) shall be at least 600 mm. In position 2 it shall be at least 380 mm.
- (5) Where access is provided from the deck above as an alternative to access from the freeboard deck, then the height of sills into a bridge or poop shall be 380 mm. The same shall apply to deckhouses on the freeboard deck. Where access is not provided from above, the height of the sills to doorways in deckhouses on the freeboard deck shall be 600 mm.
- (6) Where the closing appliances of access openings in superstructures and deckhouses are not in accordance with regulation **Pt 3, Ch 16, 301**., interior deck openings shall be considered exposed (i.e. situated in the open deck).
- (7) Openings in the top of a deckhouse on a raised quarterdeck or superstructure of less than standard height, having a height equal to or greater than the standard quarterdeck height, shall be provided with an acceptable means of closing but need not be protected by an efficient deckhouse or companionway as defined in the regulation, provided that the height of the deckhouse is at least the standard height of a superstructure.  
Openings in the top of the deck house on a deck house of less than a standard superstructure height may be treated in a similar manner. ↓

## CHAPTER 3 BOW DOORS, SIDE AND STERN DOORS

### Section 1 Bow Doors and Inner Doors

#### 101. General

##### 1. Application

- (1) These requirements apply to the arrangement, strength and securing of bow doors and inner doors leading to a complete or long forward enclosed superstructure or to a long non-enclosed superstructure, where fitted to attain minimum bow height equivalence.
- (2) The requirements apply to all ro-ro passenger ships and ro-ro cargo ships engaged on international voyages and also to ro-ro passenger ships and ro-ro cargo ships engaged only in domestic (non-international) voyages, except where specifically indicated otherwise herein. Where differently deliberated by the competent Flag Administrations, shall be in accordance with the relevant requirements of Flag Administrations. (2018)
- (3) The requirements are not applicable to high speed, light displacement craft as defined in the IMO Code of Safety for High Speed Craft.
- (4) The bow door and inner door of all existing ro-ro passenger ships constructed before or on 30 June 1996 are to be deemed appropriate by the Society. **[See Guidance]**

##### 2. Kinds of bow doors

The kinds of bow doors which are applied by this Chapter are generally two types as follows. However, other types of bow doors will be specially considered in association with the applicable requirements of these rules by the Society, except for following (1) and (2).

- (1) Visor door  
Visor doors opened by rotating upwards and outwards about a horizontal axis through two or more hinges located near the top of the door and connected to the primary structure of the door by longitudinally arranged lifting arms.
- (2) Side-opening door  
Side-opening doors opened either by rotating outwards about a vertical axis through two or more hinges located near the outboard edges or by horizontal translation by means of linking arms arranged with pivoted attachments to the door and the ship. It is anticipated the side-opening bow doors are arranged in pairs.

##### 3. Arrangement

Arrangements for the bow door and inner door are to comply with the following (1) to (5)

- (1) Bow doors are to be situated above the freeboard deck except that where a watertight recess fitted for arrangement of ramps or other related mechanical devices is located forward of the collision bulkhead and above the deepest waterline, the bow doors may be situated above the recess.
- (2) An inner door which is to be part of the collision bulkhead is to be fitted. The inner door does not need to be fitted directly above the bulkhead. Where the vehicle ramp is arranged as a part of collision bulkhead, and its position complies with requirements of **Pt 3, Ch 14, 201.** of the Rules, the vehicle ramp may be regarded as an inner door. If this is not possible, a separate inner weather door is to be installed.
- (3) Bow doors and inner doors are to be arranged so as to preclude the possibility of the bow door causing structural damage to the inner door or to the collision bulkhead in the case of damage to or detachment of the bow door. If this is not possible, a separate inner weathertight door is to be installed, as indicated in **Pt 3, Ch 14, 201.** of the Rules
- (4) Bow doors are to be so fitted as to ensure tightness consistent with operational conditions and to give effective protection to inner doors. Inner doors forming part of the collision bulkhead are to be weathertight over the full height of the cargo space and arranged with fixed sealing supports on the aft side of the doors.
- (5) The requirements for inner doors are based on the assumption that vehicle are effectively lashed and secured against movement in stowed position.

#### 4. Definitions

The definitions which are used in this Chapter are as follows.

(1) Securing device

A device used to keep the door closed by preventing it from rotating about its hinges or its pivoted attachments to the ship.

(2) Supporting device

A device used to transmit external or internal loads from the door to a securing device and from the securing device to the ship's structure, or a device other than a securing device, such as a hinge, stopper or other fixed devices, that transmits loads from the door to the ship's structure.

(3) Locking device

A device that locks a securing device in the closed position.

(4) Ro-ro passenger ship

Passenger ship with ro-ro spaces or special category spaces.

(5) Ro-ro spaces

Ro-ro spaces are spaces not normally sub-divided in any way and normally extending to either a substantial length or the entire length of the ship, in which motor vehicles with fuel in their tanks for their own propulsion and/or goods (packaged or in bulk, in or on rail or road cars, vehicles (including road or rail tankers), trailers, containers, pallets, demountable tanks or in or on similar stowage units or, other receptacles) can be loaded and unloaded normally in a horizontal direction.

(6) Special category spaces

Special category spaces are those enclosed vehicle spaces above or below the bulkhead deck, into and from which vehicles can be driven and to which passengers have access. Special category spaces may be accommodated on more than one deck provided that the total overall clear height for vehicles does not exceed 10 m.

### 102. Strength criteria

#### 1. Primary structure and securing and supporting devices

Scantlings of the primary members, securing and supporting devices of bow doors and inner doors are to be determined to withstand the design loads defined in **103.**, using the following permissible stresses of **Table 4.3.1.**

**Table 4.3.1 Permissible stress for primary members, securing and supporting devices**

Stress	Permissible stress (N/mm <sup>2</sup> )
Shear stress ( $\tau$ )	$\tau = 80/K$
Bending stress ( $\sigma$ )	$\sigma = 120/K$
Equivalent stress ( $\sigma_e = \sqrt{\sigma^2 + 3\tau^2}$ )	$\sigma_e = 150/K$
$K =$ material factor as specified in <b>Table 4.3.2</b>	

2. The buckling strength of primary members is to be verified as being adequate.

#### 3. Stress of steel bearings in securing and supporting devices

For steel to steel bearings in securing and supporting devices, the nominal bearing pressure calculated by dividing the design force by the projected bearing area is not to exceed  $0.8\sigma_y$ .

$\sigma_y$  = the yield stress of the bearing material

#### 4. Tensile stress on threaded bolts

The arrangement of securing and supporting devices is to be such that threaded bolts do not carry support forces. The maximum tension in way of bolts not carrying support forces is not to exceed  $125/K$  (N/mm<sup>2</sup>).

$K =$  material factor as specified in **Table 4.3.2.**

### 103. Design loads

#### 1. Bow doors

##### (1) External pressure

Design external pressure  $P_e$ , to be considered for the scantlings of primary members, securing and supporting devices of bow doors is to be taken as indicated by the following formula.

$$P_e = 2.75\lambda C_H(0.22 + 0.15\tan\alpha) (0.4 V\sin\beta + 0.6\sqrt{L})^2 \quad (\text{kN/m}^2)$$

where :

$V$  = contractual ship's speed, in knots

$L$  = ship's length, in m, as specified in **Pt 3, Ch 1, 102.** of the Rules, but need not be taken greater than 200 m.

$\lambda$  = coefficient depending on the area where the ship is intended to be operated :

for sea going ships  $\lambda = 1.0$

for ships operated in coastal waters  $\lambda = 0.8$

for ships operated in sheltered waters  $\lambda = 0.5$

$C_H$  = coefficient that obtained from ship length as specified in **Table 4.3.3.**

$\alpha$  = flare angle at the point to be considered, defined as the angle between a vertical line and the tangent to the side shell plating measured in a vertical plane normal to the horizontal tangent to the shell plating (See **Fig 4.3.1**).

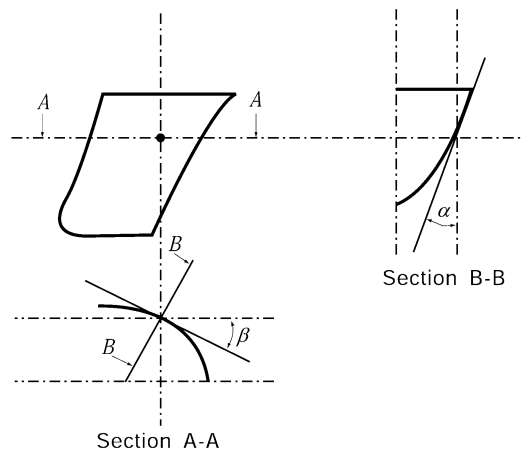
$\beta$  = entry angle at the point to be considered, defined as the angle between a longitudinal line parallel to the centerline and the tangent to the shell plating in a horizontal plane (See **Fig 4.3.1**).

**Table 4.3.2** Material factor  $K$

Material	$K$
A, B, D or E	1.0
AH 32, DH 32 or EH 32	0.78
AH 36, DH 36 or EH 36	0.72

**Table 4.3.3** Coefficient  $C_H$

$L$	$C_H$
$L < 80m$	$L/80$
$L \geq 80m$	1.0



**Fig 4.3.1** Entry and flare angle

(2) External forces

The design external forces considered in determining scantlings of securing and supporting devices of bow doors are not to be taken less than those given by the following formulae.

$$F_x = P_{em} A_x$$

$$F_y = P_{em} A_y$$

$$F_z = P_{em} A_z$$

$F_x$  = the design external force (kN) in the longitudinal direction.

$F_y$  = the design external force (kN) in the horizontal direction.

$F_z$  = the design external force (kN) in the vertical direction.

$A_x$  = area, in m<sup>2</sup>, of the transverse vertical projection of the door between the levels of the bottom of the door and the top of the upper deck bulwark, or between the bottom of the door and the top of the door, including the bulwark, where it is part of the door, whichever is the lesser. (see **Fig 4.3.2**)

Where the flare angle of the bulwark is at least 15 degrees less than the flare angle of the adjacent shell plating, the height from the bottom of the door may be measured to the upper deck or to the top of the door, whichever is lesser. In determining the height from the bottom of the door to the upper deck or to the top of the door, the bulwark is to be excluded.

$A_y$  = area, in m<sup>2</sup>, of the longitudinal vertical projection of the door between the levels of the bottom of the door and the top of the upper deck bulwark, or between the bottom of the door and the top of the door, including the bulwark, where it is part of the door, whichever is the lesser. (see **Fig 4.3.2**)

Where the flare angle of the bulwark is at least 15 degrees less than the flare angle of the adjacent shell plating, the height from the bottom of the door may be measured to the upper deck or to the top of the door, whichever is lesser.

$A_z$  = area, in m<sup>2</sup>, of the horizontal projection of the door between the levels of the bottom of the door and the top of the upper deck bulwark, or between the bottom of the door and the top of the door, including the bulwark, where it is part of the door, whichever is the lesser. (see **Fig 4.3.2**)

Where the flare angle of the bulwark is at least 15 degrees less than the flare angle of the adjacent shell plating, the height from the bottom of the door may be measured to the upper deck or to the top of the door, whichever is lesser.

$h$  = height(m) of the door between the levels of the bottom of the door and the upper deck, or between the bottom of the door and the top of the door, whichever is lesser.

$l$  = fore and aft length(m<sup>2</sup>) of the door at a height  $h/2$  above the bottom of the door.

$P_{em}$  = external pressure, in kN/m<sup>2</sup>, as given in **103.1** (1) with angles  $\alpha_m$  and  $\beta_m$  defined as follows :

$\alpha_m$  = flare angle measured at a point on the bow door  $l/2$  aft of the stem line on a plane  $h/2$  above the bottom of the door (See **Fig 4.3.3**).

$\beta_m$  = entry angle measured at a point on the bow door  $l/2$  aft of the stem line on a plane  $h/2$  above the bottom of the door (See **Fig 4.3.3**).

For doors, including bulwark, of unusual form or proportions, e.g. ships with a rounded nose and large stem angles, the area and angles used for determination of the design values of external forces may require to be specially considered.

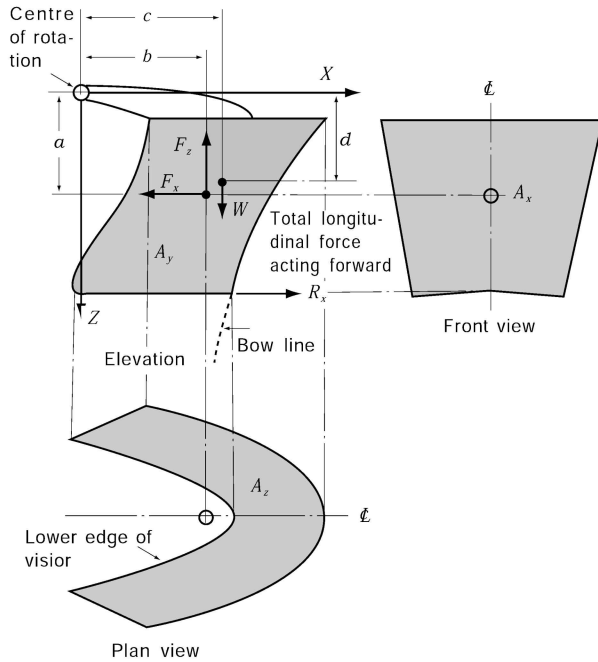


Fig 4.3.2 Visor type bow door

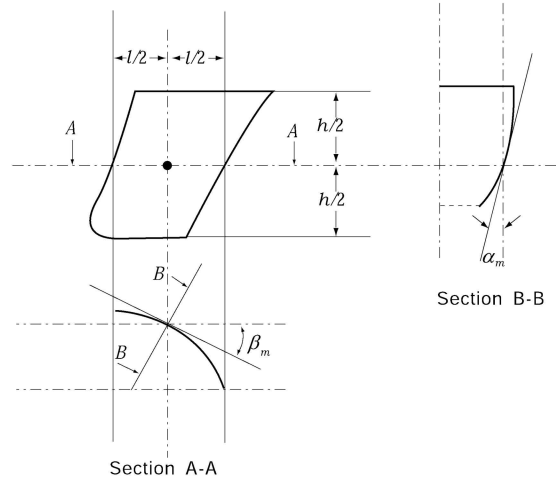


Fig 4.3.3  $\alpha_m$  and  $\beta_m$

- (3) For visor doors the closing moment  $M_y$  under external loads, in kN-m, is to be taken as the following formula.

$$M_y = F_x a + 10 Wc - F_z b \quad (\text{kN-m})$$

$F_x$  and  $F_z$  = as specified in above (2).

$W$  = mass of the visor door (ton)

$a$  = vertical distance from visor pivot to the centroid of the transverse vertical projected area of the visor door (m)

$b$  = horizontal distance from visor pivot to the centroid of the horizontal projected area of the visor door (m)

$c$  = horizontal distance from the visor pivot to the center of gravity of the visor mass (m)

- (4) Moreover, the lifting arms of a visor door and its supports are to be dimensioned for the static and dynamic forces applied during the lifting and lowering operations, and a minimum wind pressure of  $1.5 \text{ kN/m}^2$  is to be taken into account.

## 2. Inner door

- (1) External pressure

The design external pressure, in  $\text{kN/m}^2$ , considered for the scantlings of primary members, securing and supporting devices and surrounding structure of inner doors is to be taken as the greater of  $P_{e1}$  or  $P_{e2}$  as given by the following formulae.

$$P_{e1} = 0.45 L \quad (\text{kN/m}^2), \quad P_{e2} = 10 h \quad (\text{kN/m}^2)$$

$h$  = the distance from the load point to the top of the cargo space (m).

$L$  = ship's length(m), as defined in Pt 3, Ch 1, 102. of the Rules. But need not be taken greater than 200 m.

(2) Internal pressure

The design internal pressure,  $P_i$ , considered for the scantlings of securing devices of inner doors is not to be less than 25 kN/m<sup>2</sup>.

## 104. Scantlings of bow doors

### 1. General

- (1) The strength of bow doors is to be commensurate with that of the surrounding structure.
- (2) Bow doors are to be adequately stiffened and means are to be provided to prevent lateral or vertical movement of the doors when closed. For visor doors adequate strength for the opening and closing operations is to be provided in the connections of the lifting arms to the door structure and to the ship structure.

### 2. Primary structure

Scantlings of the primary members are generally to be supported by direct strength calculations in association with the external pressure given in **103. 1. (1)** and permissible stresses given in **Table 4.3.1**. Normally, formulae for simple beam theory may be applied to determine the bending stress. Members are to be considered to have simply supported end connections.

### 3. Secondary stiffeners

Secondary stiffeners are to be supported by primary members constituting the main stiffening of the door. The section modulus of secondary stiffeners is not to be less than that required for end framing. Consideration is to be given, where necessary, to differences in fixity between ship's frames and bow doors stiffeners. In addition, stiffener webs are to have a net sectional area,  $A$ , not less than that obtained from the following formula.

$$A = \frac{QK}{10} \quad (\text{cm}^2)$$

$Q$  = shear force (kN) in the stiffener calculated by using uniformly distributed external pressure  $P_e$

$P_e$  = as specified in **103. 1. (1)**

$K$  = material factor as specified in **Table 4.3.2**

### 4. Plating

The thickness of bow door plating is to be not less than that required for the side shell plating, using bow door stiffener spacing, but in no case less than the minimum required thickness of fore end shell plating.

## 105. Scantlings of inner doors

### 1. General

- (1) Scantlings of the primary members are generally to be supported by direct strength calculations in association with the external pressure given in **103. 2. (1)** and permissible stresses given in **Table 4.3.1**. Normally, formulae for simple beam theory may be applied.
- (2) Where inner doors also serve as a vehicle ramps, the scantlings are not to be less than those required for vehicle decks.

## 106. Securing and supporting of bow doors

### 1. General

- (1) Bow doors are to be fitted with adequate means of securing and supporting so as to be commensurate with the strength and stiffness of the surrounding structure.
- (2) The hull supporting structure in way of the bow doors is to be suitable for the same design loads and design stresses as the securing and supporting devices.
- (3) Where packing is required, the packing material is to be of a comparatively soft type, and the

supporting forces are to be carried by the steel structure only. Other types of packing may be considered.

- (4) Maximum design clearance between securing and supporting devices is not generally to exceed 3 mm.
- (5) A means is to be provided for mechanically fixing the door in the open position.
- (6) Only the active supporting and securing devices having an effective stiffness in the relevant direction are to be included and considered to calculate the reaction forces acting on the devices.
- (7) Small and/or flexible devices such as cleats intended to provide load compression of the packing material are not generally to be included in the calculations.
- (8) The number of securing and supporting devices are generally to be the minimum practical whilst taking into account the requirements for redundant provision given in **Par 2** (6), (7) and the available space for adequate support in the hull structure.
- (9) For opening outwards visor doors, the pivot arrangement is generally to be such that the visor is self closing under external loads, that  $M_y > 0$ . Moreover, the closing moment  $M_y$  as given in **103. 1**, (3) (A) is to be not less than:

$$M_{y0} = 10 Wc + 0.1 \sqrt{a^2 + b^2} \times \sqrt{F_x^2 + F_z^2} \quad (\text{kN-m})$$

$W$ ,  $a$ ,  $b$ ,  $c$ ,  $F_x$  and  $F_z$  = as specified in **103**.

## 2. Scantlings

- (1) Securing and supporting devices are to be adequately designed so that they can withstand the reaction forces within the permissible stresses given in **Table 4.3.1**.
- (2) For visor doors the reaction forces applied on the effective securing and supporting devices assuming the door as a rigid body are determined for the following combination of external loads acting simultaneously together with the self weight of the door :
  - (A) Case 1  $F_x$  and  $F_z$
  - (B) Case 2  $0.7 F_y$  acting on each side separately together with  $0.7 F_x$  and  $0.7 F_z$  where  $F_x$ ,  $F_y$  and  $F_z$  are determined as indicated in **103. 1**. (2) and applied at the centroid of projected areas.
- (3) For side-opening doors the reaction forces applied on the effective securing and supporting devices assuming the door as a rigid body are determined for the following combination of external loads acting simultaneously together with the self weight of the door:
  - (A) Case 1  $F_x$ ,  $F_y$  and  $F_z$
  - (B) Case 2  $0.7 F_x$  and  $0.7 F_z$  acting on both doors and  $0.7 F_y$  acting on each door separately. where  $F_x$ ,  $F_y$  and  $F_z$  are determined as indicated in **103. 1**. (2) and applied at the centroid of projected areas.
- (4) The support forces as determined according to above (2) (A) and (3) (A) shall generally give rise to a zero moment about the transverse axis through the centroid of the area  $A_x$ . For visor doors, longitudinal reaction forces of pin and/or wedge supports at the door base contributing to this moment are not to be of the forward direction.
- (5) The distribution of the reaction forces acting on the securing and supporting devices may require to be supported by direct calculations taking into account the flexibility of the hull structure and the actual position and stiffness of the supports.
- (6) The arrangement of securing and supporting devices in way of these securing devices is to be designed with redundancy so that in the event of failure of any single securing or supporting device the remaining devices are capable to withstand the reaction forces without exceeding by more than 20 percent the permissible stresses as given in **Table 4.3.1**.
- (7) For visor doors, two securing devices are to be provided at the lower part of the door, each capable of providing the full reaction force required to prevent opening of the door within the permissible stresses given in **Table 4.3.1**. The opening moment  $M_0$ , in kN-m, to be balanced by this reaction force, is not to be taken less than:

$$M_0 = 10 Wd + 5A_x a \quad (\text{kN-m})$$

where :

$A_x$  = as specified in 103. 1. (2)

$a$  = as specified in 103. 1. (3)

$d$  = vertical distance from the hinge axis to centre of gravity of the door (m)

$W$  = as specified in 103. 1. (3)

- (8) For visor doors, the securing and supporting devices excluding the hinges should be capable of resisting the vertical design force ( $F_z - 10W$ ), in kN, within the permissible stresses given in **Table 4.3.1**.
- (9) All load transmitting elements in the design load path, from door through securing and supporting devices into the ship structure, including welded connections, are to be to the same strength standard as required for the securing and supporting devices. These elements include pins, supporting brackets and back-up brackets.
- (10) For side-opening doors, thrust bearing has to be provided in way of girder ends at the closing of the two leaves to prevent on leaf to shift towards the other one under effect of unsymmetrical pressure (See **Fig 4.3.4**). Each part of the thrust bearing has to be kept secured on the other part by means of securing devices.

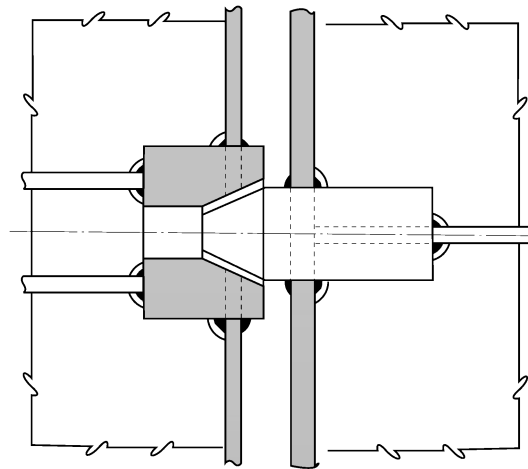


Fig 4.3.4 Example of thrust bearing

## 107. Securing and locking arrangement

Securing devices are to be equipped with mechanical locking arrangement (self locking or separate arrangement), or to be of the gravity type. Those devices are to comply with the requirements of the following **Par 1.** and **2.**

### 1. Operation

Securing devices are to be simple to operate and easily accessible. The opening and closing systems as well as securing and locking devices are to be interlocked in such a way that they can only operate in the proper sequence.

#### (1) Hydraulic securing devices

Where hydraulic securing devices are applied, the system is to be mechanically lockable in closed position. This means that, in the event of loss of the hydraulic fluid, the securing devices remain locked. The hydraulic system for securing and locking devices is to be isolated from other hydraulic circuits, when in closed position.

#### (2) Bow doors and inner doors giving access to vehicle decks are to be provided with an arrangement for remote control, from a position above the freeboard deck, of

(A) the closing and opening of the doors, and

(B) associate securing and locking devices for every door.

#### (3) Remote control

Indication of the open/closed position of every door and every securing and locking device is to be provided at the remote control stations. The operating panels for operation of doors are to

be inaccessible to unauthorized persons. A notice plate, giving instructions to the effect that all securing devices are to be closed and locked before leaving harbour, is to be placed at each operating panel and is to be supplemented by warning indicator lights.

## **2. Indication and monitoring**

- (1) Separate indicator lights and audible alarms are to be provided on the navigation bridge and on the operating panel to show that the bow door and inner door are closed and that their securing and locking devices are properly positioned. The indication panel is to be provided with a lamp test function. It shall not be possible to turn off the indicator light.
- (2) The indicator system is to be designed on the fail safe principle and is to show by visual alarms if the door is not fully closed and not fully locked and by audible alarms if securing devices become open or locking devices become unsecured. The power supply for the indicator system for operating and closing doors is to be independent of the power supply for operating and closing the doors and is to be provided with a back-up power supply from the emergency source of power or other secure power supply e.g. UPS. The sensors of the indicator system are to be protected from water, ice formation and mechanical damage.
- (3) The indication panel on the navigation bridge is to be equipped with a mode selection function "harbour/sea voyage", so arranged that audible alarm is given on the navigation bridge if the vessel leaves harbour with the bow door or inner door not closed or with any of the securing devices not in the correct position.
- (4) A water leakage detection system with audible alarm and television surveillance is to be arranged to provide an indication to the navigation bridge and to the engine control room of leakage through the inner door.
- (5) Between the bow door and the inner door a television surveillance system is to be fitted with a monitor on the navigation bridge and in the engine control room. The system is to monitor the position of the doors and a sufficient number of their securing devices. Special consideration is to be given for the lighting and contrasting colour of objects under surveillance.
- (6) A drainage system is to be arranged in the area between bow door and ramp or where no ramp is fitted between the bow door and inner door. The system is to be equipped with an audible alarm function to the navigation bridge being set off when the water levels in these areas exceed 0.5m or the high water level alarm, whichever is lesser.
- (7) The indicator system is considered designed on the fail - safe principal in above (2) to (6) when:
  - (A) The indication panel is provided with:
    - a power failure alarm
    - an earth failure alarm
    - a lamp test
    - separate indication for door closed, door locked, door not closed and door not locked.
  - (B) Limit switches electrically closed when the door is closed (when more limit switches are provided they may be connected in series).
  - (C) Limit switches electrically closed when securing arrangements are in place (when more limit switches are provided they may be connected in series).
  - (D) Two electrical circuits (also in one multicore cable), one for the indication of door closed / not closed and the other for door locked / not locked.
  - (E) In case of dislocation of limit switches, indication to show : not closed / not locked / securing arrangement not in place - as appropriate.
- (8) For ro-ro passenger ships on international voyages, the special category spaces and ro-ro spaces are to be continuously patrolled or monitored by effective means, such as television surveillance, so that any movement of vehicles in adverse weather conditions or unauthorized access by passengers thereto, can be detected whilst the ship is underway.

## **108. Operating and maintenance manual**

1. An Operating and Maintenance Manual for the bow door and inner door is to be provided on board and is to contain necessary information after approval of this Society.
  - (1) main particulars and design drawings
    - (A) special safety precautions
    - (B) details of vessel
    - (C) equipment and design loading (for ramps)

- (D) key plan of equipment (doors and ramps)
- (E) manufacturer's recommended testing for equipment
- (F) description of equipment for
  - (a) bow doors
  - (b) inner bow doors
  - (c) bow ramp/doors
  - (d) side doors
  - (e) stern doors
  - (f) central power pack
  - (g) bridge panel
  - (h) engine control room panel
- (2) service conditions
  - (A) limiting heel and trim of ship for loading/unloading
  - (B) limiting heel and trim for door operations
  - (C) doors/ramps operating instructions
  - (D) doors/ramps emergency operating instructions
- (3) maintenance
  - (A) schedule and extent of maintenance
  - (B) trouble shooting and acceptable clearances
  - (C) manufacturer's maintenance procedures
- (4) register of inspections, including inspection of locking, securing and supporting devices, repairs and renewals.

This Manual has to be submitted for approval that the above mentioned items are contained in the OMM and that the maintenance part includes the necessary information with regard to inspections, trouble-shooting and acceptance / rejection criteria.

2. Documented operating procedures for closing and securing the bow door and inner door are to be kept on board and posted in appropriate place.

## Section 2 Side and Stern Doors

### 201. General

#### 1. Application

- (1) These rules give requirements for the arrangement, strength and securing of side shell doors, abaft the collision bulkhead, and stern doors leading into enclosed spaces.
- (2) The side shell door and stern door of all existing ro-ro passenger ships constructed before or on 30 June 1997 are to be as deemed appropriate by the Society. **[See Guidance]**

#### 2. Arrangement

- (1) Stern doors for passenger vessels are to be situated above the freeboard deck. Stern doors for ro-ro cargo ships and side shell doors may be either below or above the freeboard deck.
- (2) The side and stern doors are to be so fitted as to ensure tightness and structural integrity commensurate with their location and the surrounding structure.
- (3) In general, the lower edge of door openings is not to be below a line drawn parallel to the freeboard deck at side, which has at its lowest point the upper edge of the uppermost load line.
- (4) Where side door and stern door are unavoidably provided below the line as stipulated in above (3), the following conditions are to be satisfied.
  - (A) Compartment being equivalent to watertight-bulkhead in strength and watertightness is to be provided and the second door is to be fitted for the compartment.
  - (B) Detecting device for sea water leakage is to be provided in the compartment and drainage means of the compartment with a screw-down stop valve capable of being controlled from easily accessible position is to be provided.
- (5) Doors are generally to be arranged to open outwards.

#### 3. Definitions

The definitions specified in this Section are to be in accordance with 101. 4.

## 202. Strength criteria

### 1. Primary structure and securing and supporting devices

Scantlings of the primary members, securing and supporting devices of doors are to be determined to withstand the design loads defined in **203.**, using the following permissible stresses of **Table 4.3.1.**

2. The bucking strength of primary members is to be verified as being adequate.

### 3. Steel of steel bearings in securing and supporting devices

For steel to steel bearings in securing and supporting devices, the nominal bearing pressure calculated by dividing the design force by the projected bearing area is not to exceed  $0.8\sigma_y$ .

$\sigma_y$  = the yield stress of the bearing material.

### 4. Tensile stress on threaded bolts

The arrangements of securing and supporting devices is to be such that threaded bolts do not carry support forces. The maximum tension in way of threads bolts not carrying support forces is not to exceed  $125/K$  (N/mm<sup>2</sup>).

$K$  = material factor as specified in **Table 4.3.2.**

## 203. Design Loads

The design forces considered for the scantlings of primary members, securing and supporting devices are not to be less than the following **Par 1** to **3.**

1. Design forces for securing or supporting devices of doors opening inwards :

$$\text{External force : } F_e = AP_e + F_p \quad (\text{kN})$$

$$\text{Internal force : } F_i = F_0 + 10 W \quad (\text{kN})$$

2. Design forces for securing or supporting devices of doors opening outwards :

$$\text{External force : } F_e = AP_e \quad (\text{kN})$$

$$\text{Internal force : } F_i = F_0 + 10 W + F_p \quad (\text{kN})$$

3. Design forces for primary members is to be taken as the greater of the following two formulae :

$$\text{External force : } F_e = AP_e \quad (\text{kN})$$

$$\text{Internal force : } F_i = F_0 + 10 W \quad (\text{kN})$$

where :

$A$  = area, in  $m^2$ , of the door opening

$W$  = mass of the door (ton)

$F_p$  = total paking force in kN, packing line pressure is normally not to be taken less than 5 N/mm.

$F_0$  = the greater of  $F_c$  and  $5A$  (kN)

$F_c$  = accidental force, in kN, due to loose of cargo etc., to be uniformly distributed over the area  $A$  and not to be taken less than 300 kN. For small doors such as bunker doors and pilot doors, the value of  $F_c$  may be appropriately reduced. However, the value of  $F_c$  may be taken as zero, provided an additional structure such as an inner ramp is fitted, which is capable of protecting the door from accidental forces due to loose cargoes.

$P_e$  = external design pressure, in kN/m<sup>2</sup>, determined at the centre of gravity of the door opening and not taken less than the value obtained from the following formulae.

$$\text{for } Z_G < T, \quad 10(T - Z_G) + 25$$

for  $Z_G \geq T$ , 25

However, for stern doors of ships fitted with bow doors,  $P_e$  is not to be taken less than:

$$P_e = 0.6\lambda C_H(0.8 + 0.6\sqrt{L})^2 \quad (\text{kN/m}^2)$$

where :

$C_H$  = coefficient that obtained from ship's length as specified in **Table 4.3.3**.

$L$  = ship's length, in m, as specified in **Pt 3, Ch 1, 102**. of the Rules, but need not be taken greater than 200 m

$Z_G$  = height of the center of area of the door, in m, above the baseline

$\lambda$  = coefficient depending on the area where the ship is intended to be operated :

for sea going ships  $\lambda = 1$

for ships operated in coastal waters  $\lambda = 0.8$

for ships operated in sheltered waters  $\lambda = 0.5$

$T$  = draught, in m, at the highest subdivision load line

## 204. Scantlings

### 1. General

- (1) In general the strength of side and stern doors is to be equivalent to the strength of the surrounding structure.
- (2) Side and stern door openings in the side shell are to have well rounded corners and adequate compensation is to be arranged with web frames at sides and stringers or equivalent above and below.
- (3) Side and stern doors are to be adequately stiffened, and means are to be provided to prevent movement of the doors when closed. Adequate strength is to be provided in the connections of the lifting/maneuvering arms and hinges to the door structure and to the ship structure.
- (4) Where side and stern doors also serve as vehicle ramps, the design of the hinges should take into account the ship angle of trim which may result in uneven loading on the hinges.

### 2. Plating

- (1) The thickness of the side and stern door plating is not to be less than the side shell plating calculated with the door stiffener spacing, and in no case to be less than the minimum shell plate thickness.
- (2) Where side and stern doors also serve as vehicle ramps, the plating is not to be less than required for vehicle decks.

### 3. Stiffeners

- (1) The section modulus of horizontal or vertical stiffeners is not to be less than required for side framing. Consideration is to be given, where necessary, to differences in fixity between ship's frame and door stiffeners.
- (2) Where side and stern doors also serve as vehicle ramps, the stiffener scantlings are not to be less than required for vehicle decks.
- (3) Where necessary, side and stern door stiffeners are to be supported by girders or stringers.

### 4. Primary members

- (1) Scantlings of primary members are generally to be supported by direct calculations in association with the design forces given in **203. 3** and permissible stresses given in **Table 4.3.1**. Normally, formulae for simple beam theory may be applied to determine the bending stress. Members are to be considered to have simply supported end connections.
- (2) The webs of girders and stringers are to be adequately stiffened, preferably in a direction perpendicular to the shell plating.
- (3) The girder system is to be given sufficient stiffness to ensure integrity of the boundary support

of the door.

- (4) Edge stiffeners/girders should be adequately stiffened against rotation and are to have a moment of inertia,  $I$ , not less than that obtained from following formula.

$$I = 8P_I d^4 \quad (\text{cm}^4)$$

$d$  = distance (m) between closing devices.

$P_I$  = packing line pressure along edges, not to be taken less than 5 N/mm.

- (5) For edge girders supporting main door girders between securing devices, the moment of inertia is to be increased in relation to the additional force.

## 205. Securing and supporting

### 1. General

- (1) Side shell doors and stern doors are to be fitted with adequate means of securing and supporting so as to be commensurate with the strength and stiffness of the surrounding structure.
- (2) A means is to be provided for mechanically fixing the door in the open position.
- (3) The hull supporting structure in way of the doors is to be suitable for the same design loads and design stresses as the securing and supporting devices.
- (4) Where packing is required, the packing material is to be of a comparatively soft type, and the supporting forces are to be carried by the steel structure only. Other types of packing may be considered.
- (5) Maximum design clearance between securing and supporting devices is not generally to exceed 3 mm.
- (6) Only the active supporting and securing devices having an effective stiffness in the relevant direction are to be included and considered to calculate the reaction forces acting on the devices.
- (7) Small and/or flexible devices such as cleats intended to provide local compression of the packing material are not generally to be included in the calculations.
- (8) The number of securing and supporting devices are generally to be the minimum practical whilst taking into account the requirement for redundant provision given in **Par 2**, (3) and the available space for adequate support in the hull structure.

### 2. Scantlings

- (1) Securing and supporting devices are to be adequately designed so that they can withstand the reaction forces within the permissible stresses given in **Table 4.3.1**.
- (2) The distribution of the reaction forces action on the securing devices and supporting devices may require to be supported by direct calculations taking into account the flexibility of the hull structure and the actual position of the supports.
- (3) The arrangement of securing devices and supporting devices in way of these securing devices is to be designed with redundancy so that in the event of failure of any single securing or supporting device the remaining devices are capable to withstand the reaction forces without exceeding by more than 20 percent the permissible stresses as given in **Table 4.3.1**.
- (4) All load transmitting elements in the design load path, from the door through securing and supporting devices into the ship's structure, including welded connections, are to be to the same strength standard as required for the securing and supporting devices. These elements include pins, supporting brackets and back-up brackets.

## 206. Securing and locking arrangement

Securing devices are to be equipped with mechanical locking arrangement (self locking or separate arrangement), or to be of the gravity type. Those devices are to comply with the requirements of the following **Par 1** and **2**.

### 1. Operation

Securing devices are to be simple to operate and easily accessible. The opening and closing systems as well as securing and locking devices are to be interlocked in such a way that they can only operate in the proper sequence.

- (1) Doors which are located partly or totally below the free board deck with a clear opening area greater than  $6 \text{ m}^2$  are to be provided with an arrangement for remote control, from a position above the freeboard deck, of
  - (A) the closing and opening of the doors,
  - (B) associated securing and locking devices.
- (2) Remote control  
For doors which are required to be equipped with a remote control arrangement, indication of the open/closed position of the door and the securing and locking device is to be provided at the remote control stations. The operating panels for operation of doors are to be inaccessible to unauthorized persons. A notice plate, giving instructions to the effect that all securing devices are to be closed and locked before leaving harbour, is to be placed at each operating panel and is to be supplemented by warning indicator lights.
- (3) Hydraulic securing devices  
Where hydraulic securing devices are applied, the system is to be mechanically lockable in closed position. This means that, in the event of loss of the hydraulic fluid, the securing devices remain locked. The hydraulic system for securing and locking devices is to be isolated from other hydraulic circuits, when closed position.

## **2. Systems for indication/monitoring**

The following requirements apply to doors in the boundary of special category spaces or ro-ro spaces. For cargo ships, where no part of the door is below the uppermost waterline and the area of the door opening is not greater than  $6 \text{ m}^2$ , then the requirements of this section need not be applied.

- (1) Indicators  
The indicator system is to be designed on the fail safe principle and in accordance with the following (A) to (D).
  - (A) Location and type  
Separate indicator lights and audible alarms are to be provided on the navigation bridge and on each operating panel to indicate that the doors are closed and that their securing and locking devices are properly positioned. The indication panel on the navigation bridge is to be equipped with mode a section function "harbour/sea voyage", so arranged that audible alarm is given if vessel leaves harbor with side shell or stern doors not closed or with any of the securing devices not in the correct position.
  - (B) Indicator lights  
Indicator lights are to be designed so that they cannot be manually turned off. The indication panel is to be provided with a lamp test-function
  - (C) Power supply  
The power supply for the indicator system is to be independent of the power supply for operating and closing the doors and is to be provided with a backup power supply.
  - (D) Protection of sensors  
The sensors of the indicator system are to be protected from water, ice formation and mechanical damage.
- (2) Water leakage protection
  - (A) For passenger ships, a water leakage detection system with audible alarm and television surveillance is to be arranged to provide an indication to the navigation bridge and to the engine control room of leakage through the side shell and stern doors.
  - (B) For cargo ships, a water leakage detection system with audible alarm is to be arranged to provide an indication to the navigation bridge of leakage through the side shell and stern doors.

## **207. Operating and maintenance manual**

1. An Operating and Maintenance Manual for the bow door and inner door is to be provided on board and is to contain necessary information after approval of this society.
  - (1) main particulars and design drawings
    - (A) special safety precautions
    - (B) details of vessel
    - (C) equipment and design loading (for ramps)
    - (D) key plan of equipment (doors and ramps)

- (E) manufacturer's recommended testing for equipment
- (F) description of equipment for
  - (a) bow doors
  - (b) inner bow doors
  - (c) bow ramp/doors
  - (d) side doors
  - (e) stern doors
  - (f) central power pack
  - (g) bridge panel
  - (h) engine control room panel
- (2) service conditions
  - (A) limiting heel and trim of ship for loading/unloading
  - (B) limiting heel and trim for door operations
  - (C) doors/ramps operating instructions
  - (D) doors/ramps emergency operating instructions
- (3) maintenance
  - (A) schedule and extent of maintenance
  - (B) trouble shooting and acceptable clearances
  - (C) manufacturer's maintenance procedures
- (4) register of inspections, including inspection of locking, securing and supporting devices, repairs and renewals.

This Manual has to be submitted for approval that the above mentioned items are contained in the OMM and that the maintenance part includes the necessary information with regard to inspections, trouble-shooting and acceptance / rejection criteria.

2. Documented operating procedures for closing and securing side shell and stern doors are to be kept on board and posted at the appropriate places. ⚓

# CHAPTER 4 BULWARKS, FREEING PORTS, SIDE SCUTTLES, RECTANGULAR WINDOWS, SKYLIGHTS VENTILATORS AND PERMANENT GANGWAYS

## Section 1 Bulwarks and Guardrails

### 101. Arrangements [See Guidance]

Bulwarks or guardrails are to be provided on all exposed parts of the freeboard and superstructure decks and on top of all other exposed deck houses. The height of bulwarks and guardrails is to be at least 1 *metre* from the top of deck. Where this height is considered to interfere with the normal operation of the ship and where deemed necessary by the Society, a lesser height may be permitted subject to the Society's approval.

### 102. Strength of bulwarks

1. The bulwarks are to be strongly constructed and effectively stiffened on their upper edge.
2. The thickness of bulwarks on the freeboard decks is not to be less than 6 *mm*.
3. Bulwarks are to be supported by strong stays attached to deck in way of the beams and spaced not more than 1.8 m apart on freeboard deck.
4. Stays are to be made of bulb plates or flanged plates and effectively attached to deck and bulwark.

### 103. Bulwarks of timber carriers

Decks which are designed to carry timber deck cargoes are to be provided with bulwarks more than 1 m in height or with specially strong guardrails. The upper edges of the bulwarks are to be well stiffened and supported by specially strong stays spaced not more than 1.5 m and attached to deck in way of the beams. Necessary freeing ports are to be provided in the bulwarks.

### 104. Reinforcement of bulwarks

1. Gangways and other openings in bulwarks are to be well clear of the breaks of superstructures.
2. Where bulwarks are cut to form gangways or other openings, stays of increased strength are to be provided at the ends of the openings.
3. The plating of bulwarks in way of mooring pipes or eye plates for cargo handling is to be doubled or increased in thickness.
4. At the ends of superstructures, the bulwark rails are to be bracketed either to the superstructure end bulkheads or to the stringer plates of the superstructure decks, or other equivalent arrangements are to be made so that the abrupt change of strength is avoided.

### 105. Expansion joint

Long bulwarks are to be so arranged that they are not affected as far as possible by the stress of the main hull structures and expansion joints are to be provided all suitable locations.

### 106. Guardrails [See Guidance]

1. Guard rails fitted on superstructure and freeboard decks shall have at least three courses. The opening below the lowest course of the guard rails shall not exceed 230 mm. The other courses shall be not more than 380 mm apart. In the case of ships with rounded gunwales the guard rail supports shall be placed on the flat of the deck. In other locations, guardrails with at least two courses shall be fitted.
2. Fixed, removable or hinged stanchions shall be fitted about 1.5 m apart. Removable or hinged stanchions shall be capable of being locked in the upright position. At least every third stanchion shall be supported by a bracket or stay.

3. Where necessary for the normal operation of the ship, steel wire ropes may be accepted in lieu of guard rails. Wires shall be made taut by means of turnbuckles. And chains fitted between two fixed stanchions and/or bulwarks are acceptable in lieu of guard rails.

## Section 2 Freeing Ports

### 201. General [See Guidance]

1. Where bulwarks on the weather portions of freeboard or superstructure decks form wells, ample provision is to be made for rapidly freeing the decks of water and for draining them.
2. Ample freeing ports are to be provided for clearing any space other than wells, where water is liable to be shipped and to remain.
3. In ships having superstructures which are open at either or both ends, adequate provision for freeing the space within superstructures is to be provided.
4. In ships having a reduced freeboard, guardrails are to be provided for at least a half of the length of the exposed parts of weather deck or other effective freeing arrangements are to be considered, as required by the Society.

### 202. Freeing port area [See Guidance]

1. The freeing port area on each side of the ship for each well on the freeboard and raised quarter decks is not to be less than that obtained from **Table 4.4.1**.

**Table 4.4.1 Total area of freeing port**

Length of bulwarks	Total area of freeing ports (m <sup>2</sup> )									
	Freeboard and raised quarter decks	Superstructure decks								
$l \leq 20$ m	$A = 0.035l + 0.7 + a$	$A = \frac{0.035l + 0.7 + a}{2}$								
$l > 20$ m	$A = 0.07l + a$	$A = \frac{0.07l + a}{2}$								
<p><math>l</math> = length of bulwark (m), but need not be taken as greater than <math>0.7L_f</math>  <math>a</math> = as obtained from the following table</p> <table border="1" style="margin-left: auto; margin-right: auto;"> <thead> <tr> <th>Height of bulwarks (m)</th> <th>Correction value (m<sup>2</sup>)</th> </tr> </thead> <tbody> <tr> <td><math>h &lt; 0.9</math></td> <td><math>a = -0.04l(0.9 - h)</math></td> </tr> <tr> <td><math>0.9 \leq h \leq 1.2</math></td> <td><math>a = 0</math></td> </tr> <tr> <td><math>1.2 &lt; h</math></td> <td><math>a = 0.04l(h - 1.2)</math></td> </tr> </tbody> </table> <p><math>h</math> = average height of bulwarks above the deck (m)</p>			Height of bulwarks (m)	Correction value (m <sup>2</sup> )	$h < 0.9$	$a = -0.04l(0.9 - h)$	$0.9 \leq h \leq 1.2$	$a = 0$	$1.2 < h$	$a = 0.04l(h - 1.2)$
Height of bulwarks (m)	Correction value (m <sup>2</sup> )									
$h < 0.9$	$a = -0.04l(0.9 - h)$									
$0.9 \leq h \leq 1.2$	$a = 0$									
$1.2 < h$	$a = 0.04l(h - 1.2)$									

2. In ships either without sheer or with less sheer than the standard, the minimum freeing port area obtained from the formulae in **Par 1** is to be increased by multiplying the factor obtained from the following formula :

$$a_0 = 1.5 - \frac{S}{2S_0}$$

where:

$S$  = average height of actual sheer (mm)

$S_0$  = average height of the standard sheer given by the International Convention on Load Lines, 1966 (mm)

- Where a ship is provided with a trunk or a hatch side coaming which is continuous or substantially continuous between detached superstructures, the area of freeing port opening is not to be less than that given by **Table 4.4.2**.

**Table 4.4.2 Area of freeing ports**

Breadth of hatchway of trunk	Area of freeing ports in relation to the total area of bulwark
$0.4 B_f$ or less	0.2
$0.75 B_f$ or more	0.1
NOTE : The area of freeing ports at intermediate breadth is to be obtained by interpolation.	

- Notwithstanding the requirements in **Par 1 to 3**, where deemed necessary by the Society in ships having trunks on the freeboard deck, guardrails are to be provided instead of bulwarks on the freeboard deck in way of trunks for more than half of the length of trunk.

#### 203. Arrangement of freeing ports [See Guidance]

The lower edges of the freeing ports are to be as near the deck as possible and two-thirds of the freeing ports area required by **202**, is to be provided in the half of the well near the lowest point of the sheer curve.

#### 204. Construction of freeing ports [See Guidance]

- Where both the length and the height of freeing ports exceed 230 mm respectively, freeing ports are to be protected by rails spaced approximately 230 mm apart.
- Where shutters are provided to freeing ports, ample clearance is to be provided to prevent jamming. Hinge pins or bearings of the shutters are to be of non-corrodible metal. Shutters are not to be provided with securing appliances.

### Section 3 Side Scuttles, Rectangular Windows and Skylights

#### 301. General [See Guidance]

- The requirements in this chapter apply to side scuttles and rectangular windows on the side shell, superstructure and deckhouse up to the third tier above the freeboard deck. The requirements for the side shell, superstructure and deckhouse above the third tier are to be as deemed appropriate by the Society.
- Notwithstanding the above **Par 1**, windows on the deckhouse up to the third tier above the freeboard deck may be as deemed appropriate by the Society subject that such windows do not interfere with watertightness of a ship and are deemed as necessary for the ship's operation such as those on a navigation bridge.

#### 302. Position of side scuttles

- No side scuttle is to be provided in such a position as its sill is below a line drawn parallel to the freeboard deck at side and having its lowest point  $0.025 B_f$  or 500 mm, above the summer load line (or timber load line), whichever is the greater. All side scuttles sill of which is below the freeboard deck and which are of hinged type are to be provided with locking arrangements.

2. Despite the requirements of **Par 1**, no side scuttle is to be provided to any space below the bulkhead deck of passenger ships and the freeboard deck of cargo ships solely engaged in carriage of cargoes.

### 303. Application of side scuttles [See Guidance]

1. Side scuttle inboard are to be type A, type B, type C side scuttles complying with the requirements in **Ch 8, Sec 8**. Unless otherwise noted, dead light shall be fitted in type A, type B of side scuttle.
2. Type A, type B and type C side scuttles are to be so arranged that their design pressure is less than the maximum allowable pressure determined to their grades and nominal diameters.
3. Side scuttle to spaces below the freeboard deck and those provided to sunken poop are to be type A side scuttle or equivalent thereto.
4. Side scuttles to spaces below freeboard deck, within the first tier of superstructure, those fitted up to the first tier of the deckhouse on the freeboard deck which have unprotected deck openings leading to spaces below the freeboard deck inside, deckhouses considered buoyant in stability calculations and those exposed to direct blow of seas are to be type A, type B side scuttle or equivalent thereto.
5. Side scuttles fitted in spaces which give direct access to an open stairway and provided in deckhouse and companion which protect the openings specified in below, are to be type A, type B side scuttle with dead light or equivalent thereto. Where cabin bulkhead or doors separate side scuttles from a direct access leading below the freeboard deck, the dead light could be omitted.
6. Side scuttles to the spaces in the second tier on the freeboard deck, protecting direct access below or considered buoyant in stability calculations, are to be type A, type B side scuttles or equivalent thereto.
7. In ships with specially reduced freeboard, side scuttles located below the waterline after flooding into compartments are to be of fixed type.

### 304. Protection of side scuttles

All side scuttles in way of the anchor housing and other similar places where they are liable to be damaged are to be protected by strong gratings.

### 305. Design pressure and maximum allowable pressure of side scuttles.

1. The design pressure of side scuttle is to be less than the maximum allowable pressure determined to their nominal diameters and classes. The design pressure  $P$  is to be determined using the following equation. [See Guidance]

$$P = 10ac(bf - y) \quad (kPa)$$

$a$ ,  $b$ ,  $c$  and  $f$ : As specified **Pt 3, Ch 17, 201.** of the Rules.

$y$  : Vertical distance from summer load line to sill of side scuttle(m). Where timber load line is given, vertical distance from timber load line to sill of side scuttle.

2. Notwithstanding the provision of **Par 1.** above, the design pressure is not to be less than minimum design pressure as given in **Table 4.4.4.**

Table 4.4.3 Maximum allowable pressure of side scuttles

Type	Nominal diameter(mm)	Glass thickness(mm)	Max. allowable pressure(kPa)
A	200	10	328
	250	12	302
	300	15	328
	350	15	241
	400	19	297
B	200	8	210
	250	8	134
	300	10	146
	350	12	154
	400	12	118
	450	15	146
C	200	6	118
	250	6	75
	300	8	93
	350	8	68
	400	10	82
	450	10	65

Table 4.4.4 Minimum design pressure

Ship's length	$L \leq 250$ m	$L > 250$ m
Exposed front bulkhead of the first tier superstructure(kPa)	$25 + L/10$	50
Othe places(kPa)	$12.5 + L/20$	25

### 306. Position of rectangular windows

No rectangular window is to be provided to spaces below the freeboard deck, the first tier of superstructure and the first tier of the deckhouse considered buoyant in stability calculations or which protect deck openings leading to spaces below the freeboard deck.

### 307. Application of rectangular windows

1. Rectangular windows inboard are to be type F, type E rectangular windows complying with the requirements in **Ch 8, Sec 9** or equivalent thereto.
2. Type E and type F rectangular windows are to be so arranged that those design pressure is less than the maximum allowable pressure determined to their nominal sizes and classes.
3. Rectangular windows to the spaces in the second tier on the freeboard deck which gives direct access to a space within the first tier of enclosed superstructure or below the freeboard deck, are to be provided with hinged deadlight or fixed shutter. Where cabin bulkhead or door separate the space within the second tier from spaces below the freeboard deck or spaces within the first tier of enclosed superstructure, application of rectangular windows to the spaces within the second tier is to be as deemed appropriate by the Society. **[See Guidance]**
4. Rectangular windows to the space in the second tier on the freeboard deck considered buoyant in stability calculations are to be provided with hinged deadlight or fixed shutter.

**308. Design pressure and maximum allowable pressure of rectangular windows.**

1. The design pressure of rectangular window is to be less than the maximum allowable pressure determined to their nominal diameters and classes. The design pressure  $P$  is to be determined using the following equation.

$$P = 10ac(bf - y) \quad (\text{kPa})$$

$a, b, c$  and  $f$  : As specified **Pt 3, Ch 17, 201.** of the Rules.

$y$  : Vertical distance from summer load line to sill of rectangular window(m).  
Where timber load line is given, vertical distance from timber load line to sill of rectangular window.

2. Notwithstanding the provision of **Par 1.** above, the design pressure is not to be less than minimum design pressure as given in **Table 4.4.4.**

**Table 4.4.5 Maximum allowable pressure of rectangular window**

Type	Nominal size Width(mm) × Height(mm)	Glass thickness (mm)	Maximum allowable pressure(kPa)
E	300 × 425	10	99
	355 × 500	10	71
	400 × 560	12	80
	450 × 630	12	63
	500 × 710	15	80
	560 × 800	15	64
	900 × 630	19	81
	1000 × 710	19	64
F	300 × 425	8	63
	355 × 500	8	45
	400 × 560	8	36
	450 × 630	8	28
	500 × 710	10	36
	560 × 800	10	28
	900 × 630	12	32
	1000 × 710	12	25
	1100 × 800	15	31

**309. Skylights**

Fixed or opening skylights shall have glass thickness appropriate to their size and position as required for side scuttles and windows. Skylight glasses in any position shall be protected from mechanical damage and where fitted in position 1 or 2, shall be provided with robust deadlights or storm covers permanently attached.

## Section 4 Ventilators

### 401. Construction of coamings

1. Ventilators placed in Position I or II, for spaces below the freeboard deck or decks of enclosed superstructures are to have coamings of steel or other equivalent material and be efficiently connected to the deck. All ventilator coamings exceeding 900 mm in height are to be specially strengthened at the support.
2. Ventilators passing through superstructures other than enclosed superstructure are to have substantially constructed coamings of steel or equivalent at the freeboard deck.
3. Small hatches, fittings and equipment on the fore deck are to be comply with the provisions of **Ch 9**.

### 402. Height of coamings [See Guidance]

The height of ventilator coamings above the upper surface of the deck is to be at least 900 mm in Position I, and 760 mm in Position II. Where the ship has an unusually large freeboard or where the ventilator serves spaces within unenclosed superstructures, the height of ventilator coamings may be suitably reduced.

### 403. Thickness of coamings

1. The thickness of ventilator coamings in Position I and II leading to spaces below the freeboard deck or within enclosed superstructures is not to be less than given by Line 1 in **Table 4.4.6**. Where the height of the coamings is reduced by the provisions in **402**, the thickness may be suitably reduced.
2. Where ventilators pass through superstructures other than enclosed superstructures, the thickness of ventilator coamings in the superstructures is not to be less than that given by Line 2 in **Table 4.4.6**. [See Guidance]

**Table 4.4.6 Thickness of ventilator coamings**

Outside diameter of ventilator (mm)		80 and under	160	230 and over but less than 330
Thickness of coaming plate (mm)	Line 1	6	8.5	8.5
	Line 2	4.5	4.5	6

NOTES:

1. For intermediate values of outside diameter of ventilator, the thickness of coaming plate is to be obtained by linear interpolation.
2. Where the outside diameter of ventilator is over 330 mm, the thickness of coaming plate is to be in accordance with the discretion of the Society.

### 404. Connection

Where no steel deck exists, a steel plate is to be fitted in way of the coaming and efficiently stiffened between the beams as may be required

### 405. Length of cowl head housing

Ventilator cowls are to be fitted up closely to the outer surface of the coamings and are to have housing not less than 380 mm in length, except that a less housing may be permitted for ventilators not greater than 200 mm in diameter.

### 406. Closing appliances

1. Ventilators to machinery and cargo spaces are to be provided with means for closing openings capable of being operated from outside the spaces in case of a fire.

2. All ventilator openings in exposed positions on the freeboard and superstructure decks are to be provided with efficient weathertight closing appliances. Where the height of coaming of any ventilator exceeds 4.5 *metres* in Position I or 2.3 *metres* in Position II, such closing appliances may be omitted unless required in **Par 1**.
3. In ships not more than 100 *metres* in length for freeboard, the closing appliances mentioned in **Par 2** are to be permanently provided; where not so provided in other ships, they are to be conveniently stowed near the ventilators to which they are to be fitted up.

#### **407. Ventilators for deckhouses**

The ventilators for the deckhouses which protect the companionways leading to spaces below the freeboard deck are to be equivalent to those for the enclosed superstructures.

### **Section 5 Permanent Gangways**

#### **501. General [See Guidance]**

Satisfactory means (in the form of guardrails, life lines, gangways or under deck passages, etc.) are to be provided for the protection of the crew in getting to and from their quarters, the machinery space and all other parts used in the necessary work of the ship.

#### **502. Ships having reduced freeboard**

In ships having a reduced freeboard, a fore and after permanent gangway is to be provided at the level of the Superstructure deck between the poop or after deckhouse and the midship bridge or deckhouse, or equivalent means of access is to be provided to carry out the purpose of gangway, such as a passage below deck. Safe and satisfactory access from the gangway level is to be available between separate crew accommodations and the machinery space.

#### **503. Construction of gangways**

The gangway specified in **502**. is to be efficiently constructed and situated as near the centre line of ship as practicable. The gangways are to be in general at least 600 mm wide and to be provided on their both sides with guardrails which are at least 1 *meter* high and comply with the requirements in **106. 1**. ↓

**CHAPTER 5 [Empty]**

**CHAPTER 6 [Empty]**

**CHAPTER 7 [Empty]**

## CHAPTER 8 EQUIPMENT NUMBER AND EQUIPMENT

### Section 1 General

#### 101. General and application [See Guidance]

1. All ships, according to their equipment number of provisions in **Sec 2**, are to be provided with anchors, chain cables, ropes, etc. which are not less than given in **Table 4.8.1**.
2. The anchors, chain cables and ropes (hereinafter referred to as "equipment") which are required to be tested and inspected to be used for ships classed with the Society are to comply with the requirements of this Chapter.
3. The equipment other than those prescribed in this Chapter may be used where specially approved in connection with the design and use. In such case, the detailed data relating to the process of manufacture of the equipment are to be submitted for approval.
4. All ships are to be provided with suitable appliances for handling of anchors as follows.
  - (1) General
    - (A) All ships are to be provided with suitable appliances for handling of anchors.
    - (B) The bower anchors given in **Table 4.8.1** are to be connected to their cables and stored on board ready for use. Anchor and chain cable are should be accordance with **Sec 3, 4**.
  - (2) Chain locker
    - (A) Chain locker is to have adequate capacity and be of a suitable form to provide for the proper stowage of the chain cable, allowing an easy direct lead for the cable into the chain pipes when the cable is fully stowed. Port and starboard cables are to have separate spaces.
    - (B) Chain locker boundaries and access opening are to be watertight.
    - (C) Spurling pipes for chain cable leading to chain locker are to be of suitable size and provided with chafing lips.
    - (D) Securing of the inboard ends of chain cables.
      - (a) The inboard ends of the chain cables are to be secured to the structures by fastening able to withstand a force not less than 15% BL nor more than 30% BL (BL = breaking load of the chain cable).
      - (b) The fastening is to be provided with a mean suitable to permit, in case of emergency, an easy slipping of the chain cable to sea, operable from an accessible position outside the chain locker.
  - (3) Chain stopper
    - (A) Chain stopper are to be provided to secure each chain cable once it is paid out.
    - (B) Securing arrangements of chain stopper are to be capable of withstanding a load equal to 80% of the breaking load of the chain cable as required by **Table 4.8.8** of **411.**, without undergoing permanent deformation.
  - (4) Windlass

Windlass of sufficient power and suitable for the size of chain is to be fitted to the ship. Where an owner requires equipment significantly in excess of Rule requirements, it is the owner's responsibility to specify increased windlass power.
  - (5) Hawse pipes
    - (A) Hawse pipes are to be of a suitable size and configuration to ensure adequate clearance and an easy lead of the chain cable from the chain stopper through the ship's side. Hawse pipes are to be of sufficient strength.
    - (B) Their position and slope are to be so arranged as to create an easy lead for the chain cables and efficient housing for the anchors, where the latter are of the retractable type, avoiding damage to the hull during these operations. For this purpose, chafing lips of suitable form with ample lay-up and radius adequate to the size of the chain cable are to be provided at the shell and deck. The shell plating in way of the hawse pipes is to be reinforced as necessary.
    - (C) Where hawse pipes are not fitted, alternative arrangements will be specially considered.
    - (D) Hawse pipes are to be securely attached to thick, doubling or insert plates, by continuous welds.
    - (E) Hawse pipes and anchor pockets are to have full rounded flanges or rubbing bars in order

to minimize the nip on the cable and to minimize the probability of cable links being subjected to high bending stresses. The radius of curvature is to be such that at least three links of chain will bear simultaneously on the rounded parts of the upper and lower ends of the hawse pipes in those areas where the chain cable is supported during paying out and hoisting and when the ship is at anchor.

- (F) On ships provided with a bulbous bow, where it is not possible to obtain a suitable clearance between shell plating and the anchors during anchor handling, local reinforcements of the bulbous bow are to be provided in the form of increased shell plate thickness.

(6) Hull supporting structure of anchor windlass and chain stopper (2018)

The hull supporting structure of anchor windlass and chain stopper is to be sufficient to accommodate the operating and sea loads.

(A) Operating loads

The operating loads are to be taken not less than:

- for chain stoppers, 80% of the chain cable breaking load
- for windlasses, where no chain stopper is fitted or the chain stopper is attached to the windlass, 80% of the chain cable breaking load
- for windlasses, where chain stoppers are fitted but not attached to the windlass, 45% of the chain cable breaking load

The operating loads are to be applied in the direction of the chain cable.

(B) Sea loads

The sea loads are to be taken according to **Ch 9, Sec 3**.

(C) Permissible stress

The permissible stresses, based on gross thickness, for hull supporting structures of windlass and chain stopper are not to be greater than the following permissible values:

- Normal stress:  $1.00 \times$  the specified minimum yield stress of the material
- Shear stress:  $0.60 \times$  the specified minimum yield stress of the material

## 102. Materials

1. The materials for equipment specified in this Chapter are to comply with the requirements in each Section and **Pt 2, Ch 1** of the Rules.
2. The test pieces and testing procedures for materials of equipment are to comply with the requirements in each Section and **Pt 2, Ch 1** of the Rules.

## 103. Process of manufacture

The process of manufactures for equipment specified in this Chapter is to comply with the requirements in each Section.

## 104. Tests and inspections

1. All equipment prescribed in this Chapter are to be tested and inspected in the presence of the Society's Surveyor in accordance with the requirements of this Chapter and are to comply with the requirements for the tests and inspections.
2. Where equipment having characteristics differing from those prescribed in this Chapter are to be tested and inspected according to the approved specification for the testing.
3. The tests and inspections for equipment may be dispensed with, where these equipment have appropriate certificates accepted by the Society. **[See Guidance]**

## 105. Execution of tests and inspections

1. The manufacturers shall afford the Surveyor all necessary facilities and access to all relevant parts of the works to enable him to verify that the approved process is adhered to.
2. All tests and inspections of equipment are to be carried out at the place of manufacturer prior to delivery.

## 106. Marking for accepted equipments

Equipment which have satisfactory complied with the required in this Chapter are to be stamped in accordance with the provisions in each Section.

## Section 2 Equipment Number

### 201. Equipment number [See Guidance]

Equipment number is the value obtained from the following formula:

$$E = \Delta^{\frac{2}{3}} + 2.0Bh + 0.1A$$

where:

$\Delta$  = molded displacement in *tonnes* to the summer load waterline.

$h$ ,  $A$  = values specified in the following (1), (2) and (3).

(1)  $h$  is the value obtained from the following formula:

$$h = f + h' \quad (\text{m})$$

where:

$f$  = vertical distance, at the midship, from the load line to the top of uppermost continuous deck beam at side (m).

$h'$  = height from the uppermost continuous deck to the top of uppermost superstructures or deckhouses having a breadth greater than  $B/4$  (m). In the calculation of  $h'$ , sheer and trim may be ignored. Where a deckhouse having a breadth greater than  $B/4$  is located above a deckhouse with a breadth of  $B/4$  or less, the narrow deckhouse may be ignored.

(2)  $A$ (side projected area) is the value obtained from the following formula: (2018)

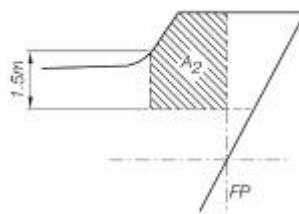
$$A = fL + \sum h'' l \quad (\text{m}^2)$$

$f$  = value specified in (1)

$\sum h'' l$  = summing up of the products of the height  $h''$  (m) and length  $l$  (m) of superstructures, deckhouses or trunks which are located above the uppermost continuous deck within the length of ship and also have a breadth greater than  $B/4$  and a height greater than 1.5 m.

(3) In the application of (1) and (2), screens and bulwarks more than 1.5 m in height are to be regarded as parts of superstructure or deckhouses. The height of the hatch coamings and that of any deck cargo, such as containers, may be disregarded when determining  $h$  and  $A$ .

With regard to determining  $A$ , when a bulwark is more than 1.5 m high, the area shown below as  $A_2$  is to be included in  $A$ . (2018)



## 202. Mass of anchors

1. The mass of individual bower anchors may vary by  $\pm 7\%$  of the mass given in **Table 4.8.1** provided that the total mass of stipulated number of bower anchors is not less than obtained from multiplying the mass per anchor by the number given in **Table 4.8.1**. Where, however, an approval by the Society is obtained, the anchors which are increased in mass by more than 7% may be used.
2. Where stock anchors are used, the mass excluding the stock, is not to be less than 0.80 times the mass specified in **Table 4.8.1** for ordinary stockless bower anchors.
3. Where high holding power anchors are used, the mass of each anchor may be 0.75 times the mass specified in **Table 4.8.1**.
4. Where super high holding power anchors are used, the mass of each anchor may be 0.5 times the mass specified in **Table 4.8.1**. However, the mass of super high holding anchor is generally not to exceed 1500 kg.

## 203. Chain cables and stream lines

1. Chain cables for bower anchors are to be stud link chains of Grade 1, 2 or 3 specified in **Sec 4**. However, Grade 1 chains made of Class 1 chain bars (*RSBC 31*) are not to be used in association with high holding power anchors.
2. As for chain cables or wire ropes for stream lines, the breaking test load specified in **Sec 4** or **5** is not to be less than the breaking load given in **Table 4.8.1** respectively.
3. Steel wire rope instead of stud link chain cable are to be in accordance with the Guidance relating to the Rules specified by the Society for vessels of special design or operation such as crane barges. **[See Guidance]**
4. The total length of chain given in **Table 4.8.1** is to be divided in approximately equal parts between the two bower anchors. (2018)

## 204. Tow lines and mooring lines

1. As for wire ropes and hemp ropes used as tow lines and mooring lines, the breaking test load specified in **Sec 5** or **6** is not to be less than the breaking load given **Table 4.8.1** respectively.
2. For ships having the ratio  $A/E$  above 0.9, the following number of ropes should be added to the number required by **Table 4.8.1** for mooring lines. However, this is to be applied only when the equipment number is not more than 2000. (2018)

$\frac{A}{E}$	Number of mooring line
$0.9 < \frac{A}{E} \leq 1.1$	1
$1.1 < \frac{A}{E} \leq 1.2$	2
$\frac{A}{E} > 1.2$	3

NOTES:

$A$  = value specified in **201**. (2)

$E$  = equipment number.

3. The requirements for synthetic fibre ropes used as tow lines or mooring lines are to be as stipulated elsewhere.
4. The length of individual mooring lines may be reduced up to 7% of the length given in **Table**

4.8.1 provided that total length of the stipulated number of mooring lines is not less than obtained from multiplying the length by the number given in Table 4.8.1.

Table 4.8.1 Bower anchors, chain cables and ropes (2018)

Equipment letter	Equipment number		Stockless bower anchors		Stud link chain cables for bower anchors			Tow line			Mooring line				
			Number	Mass per anchor (kg)	Total length (m)	Diameter (mm)			Length per line (m)	Breaking load		Number	Length per line (m)	Breaking load	
	Exceeding	Not exceeding				Grade 1	Grade 2	Grade 3		(kN)	(kg)			(kN)	(kg)
A1	-	70	2	180	220	14	12.5		180	98	10000	3	80	37	3750
A2	70	90	2	240	220	16	14		180	98	10000	3	100	40	4100
A3	90	110	2	300	247.5	17.5	16		180	98	10000	3	110	42	4300
A4	110	130	2	360	247.5	19	17.5		180	98	10000	3	110	48	4900
A5	130	150	2	420	275	20.5	17.5		180	98	10000	3	120	53	5400
B1	150	175	2	480	275	22	19		180	98	10000	3	120	59	6000
B2	175	205	2	570	302.5	24	20.5		180	112	11400	3	120	64	6500
B3	205	240	2	660	302.5	26	22	20.5	180	129	13200	4	120	69	7000
B4	240	280	2	780	330	28	24	22	180	150	15300	4	120	75	7650
B5	280	320	2	900	357.5	30	26	24	180	174	17700	4	140	80	8150
C1	320	360	2	1020	357.5	32	28	24	180	207	21100	4	140	85	8650
C2	360	400	2	1140	385	34	30	26	180	224	22800	4	140	96	9800
C3	400	450	2	1290	385	36	32	28	180	250	25500	4	140	107	10900
C4	450	500	2	1440	412.5	38	34	30	180	277	28200	4	140	117	11900
C5	500	550	2	1590	412.5	40	34	30	190	306	31200	4	160	134	13700
D1	550	600	2	1740	440	42	36	32	190	338	34500	4	160	143	14600
D2	600	660	2	1920	440	44	38	34	190	371	37800	4	160	160	16300
D3	660	720	2	2100	440	46	40	36	190	406	41400	4	160	171	17400
D4	720	780	2	2280	467.5	48	42	36	190	441	45000	4	170	187	19100
D5	780	840	2	2460	467.5	50	44	38	190	480	48900	4	170	202	20600
E1	840	910	2	2640	467.5	52	46	40	190	518	52800	4	170	218	22200
E2	910	980	2	2850	495	54	48	42	190	559	57000	4	170	235	24000
E3	980	1060	2	3060	495	56	50	44	200	603	61500	4	180	250	25500
E4	1060	1140	2	3300	495	58	50	46	200	647	66000	4	180	272	27700
E5	1140	1220	2	3540	522.5	60	52	46	200	691	70500	4	180	293	29900
F1	1220	1300	2	3780	522.5	62	54	48	200	738	75300	4	180	309	31500
F2	1300	1390	2	4050	522.5	64	56	50	200	786	80100	4	180	336	34300
F3	1390	1480	2	4320	550	66	58	50	200	836	85200	4	180	352	35900
F4	1480	1570	2	4590	550	68	60	52	220	888	90600	5	190	352	35900
F5	1570	1670	2	4890	550	70	62	54	220	941	96000	5	190	362	36900
G1	1670	1790	2	5250	577.5	73	64	56	220	1024	104400	5	190	384	39200
G2	1790	1930	2	5610	577.5	76	66	58	220	1109	113100	5	190	411	41900
G3	1930	2080	2	6000	577.5	78	68	60	220	1168	119100	5 <sup>3)</sup>	190 <sup>3)</sup>	437 <sup>3)</sup>	44600 <sup>3)</sup>
G4	2080	2230	2	6450	605	81	70	62	240	1259	128400				
G5	2230	2380	2	6900	605	84	73	64	240	1356	138300				
H1	2380	2530	2	7350	605	87	76	66	240	1453	148200				
H2	2530	2700	2	7800	632.5	90	78	68	260	1471	150000				
H3	2700	2870	2	8300	632.5	92	81	70	260	1471	150000				
H4	2870	3040	2	8700	632.5	95	84	73	260	1471	150000				
H5	3040	3210	2	9300	660	97	84	76	280	1471	150000				

Table 4.8.1 Bower anchors, chain cables and ropes (continued) (2018)

Equipment letter	Equipment number		Stockless bower anchors		Stud link chain cables for bower anchors			Tow line			Mooring line				
			Number	Mass per anchor (kg)	Total length (m)	Diameter (mm)			Length per line (m)	Breaking load		Number	Length per line (m)	Breaking load	
	Exceeding	Not exceeding				Grade 1	Grade 2	Grade 3		(kN)	(kg)			(kN)	(kg)
J1	3210	3400	2	9900	660	100	87	78	280	1471	150000				
J2	3400	3600	2	10500	660	102	90	78	280	1471	150000				
J3	3600	3800	2	11100	687.5	105	92	81	300	1471	150000				
J4	3800	4000	2	11700	687.5	107	95	84	300						
J5	4000	4200	2	12300	687.5	111	97	87	300						
K1	4200	4400	2	12900	715	114	100	87	300						
K2	4400	4600	2	13500	715	117	102	90	300						
K3	4600	4800	2	14100	715	120	105	92	300						
K4	4800	5000	2	14700	742.5	122	107	95	300						
K5	5000	5200	2	15400	742.5	124	111	97	300						
L1	5200	5500	2	16100	742.5	127	111	97							
L2	5500	5800	2	16900	742.5	130	114	100							
L3	5800	6100	2	17800	742.5	132	117	102							
L4	6100	6500	2	18800	742.5		120	107							
L5	6500	6900	2	20000	770		124	111							
M1	6900	7400	2	21500	770		127	114							
M2	7400	7900	2	23000	770		132	117							
M3	7900	8400	2	24500	770		137	122							
M4	8400	8900	2	26000	770		142	127							
M5	8900	9400	2	27500	770		147	132							
N1	9400	10000	2	29000	770		152	132							
N2	10000	10700	2	31000	770			137							
N3	10700	11500	2	33000	770			142							
N4	11500	12400	2	35500	770			147							
N5	12400	13400	2	38500	770			152							
O1	13400	14600	2	42000	770			157							
O2	14600	16000	2	46000	770			162							

NOTES :

1. Length of chain cables may be that including shackles for connection
2. Tow line and mooring line are not a condition of Classification, but is listed in this table only for guidance. Side projected area of deck cargo as given by the loading manual is to be taken into account for calculation of equipment number.(For detail, refer to IACS Rec.10 Anchoring, Mooring and Towing Equipment 2.1 and 2.2)
3. The mooring lines for ships with Equipment Number  $EN \leq 2000$  are taken this table, for ships with an Equipment Number  $EN > 2000$  are to be in accordance with the Guidance relating to the Rules specified by the Society.

5. For mooring lines connected with powered winches where the rope is stored on the drum, steel cored wire ropes of suitable flexible construction may be used instead of fibre cored wire ropes subject to the approval by the Society.

205. Emergency towing arrangements on tankers

1. For tankers which operate in international service area, emergency towing arrangements shall be fitted at both ends on board every tanker of not less than 20,000 tonnes deadweight.
2. Tankers constructed on or after 1 July 2002 are to be in accordance with the requirements in the following Sub-paragraphs.
  - (1) The arrangements shall, at all times, be capable of rapid deployment in the absence of main power on the ship to be towed and easy connection to the towing ship. At least one of the

- emergency towing arrangements shall be pre-rigged ready for rapid deployment.
- (2) Emergency towing arrangements at both ends shall be of adequate strength taking into account the size and deadweight of the ship, and the expected forces during bad weather conditions. The design, construction and prototype testing of emergency towing arrangement are to be in accordance with **Ch 3, Sec 7-1.** in "**Guidance for Approval of Manufacturing Process and Type Approval, etc**".
  3. For tankers constructed before 1 July 2002, the design, construction and prototype testing of emergency towing arrangements are to be in accordance with **Ch 3, Sec 7-1.** in "**Guidance for Approval of Manufacturing Process and Type Approval, etc**".

## **Section 3 Anchors**

### **301. Application**

Anchors to be equipped on ships in accordance with the provisions in this Chapter are to be in compliance with the requirements in this Section or to be of equivalent quality.

### **302. Kinds**

The kinds of anchors are as follows:

- (1) Ordinary anchors
  - (A) Stocked anchors
  - (B) Stockless anchors
- (2) HHP anchors
- (3) SHHP anchors, not exceeding 1,500kg in mass

### **303. Materials**

1. Cast steel anchor flukes, shanks, swivels and shackles are to be manufactured and tested in accordance with the requirements in **Pt 2, Ch 1, 501.** of the Rules and comply with the requirements for castings for welded construction. The steel is to be fine grain treated with Aluminium. If test programme B is selected in **309. 1** then Charpy V notch (CVN) impact testing of cast material is required.
2. Forged steel anchor pins, shanks, swivels and shackles are to be manufactured and tested in accordance with the requirements in **Pt 2, Ch 1, 601.** of the Rules. Shanks, swivels and shackles are to comply with the requirements for carbon and carbon-manganese steels for welded construction.
3. Rolled billets, plate and bar for fabricated steel anchors are to be manufactured and tested in accordance with the requirements in **Pt 2, Ch 1, 301.** of the Rules.
4. Rolled bar intended for pins, swivels and shackles are to be manufactured and tested in accordance with the requirements in **Pt 2, Ch 1, 301.** and **601.** of the Rules.
5. Cast steels for super high holding power anchor are to be subjected to the impact test according to the followings.
  - (1) One set of three V notch impact test specimens specified in **Pt 2, Ch 1** of the Rules are to be taken.
  - (2) The average absorbed energy is not to be less than 27 J at 0 °C. However, when the average absorbed energy of two or more test specimens among a set of test specimens is less than 27 J or when the average absorbed energy of a single test specimen is less than 19 J, the test is to be considered to have failed.
  - (3) Anchor rings of super high holding power anchor are to comply with the requirements of impact test for Grade 3 chain in **Ch 8, Table 4.8.10.**
6. All SHHP anchors are to comply with the following material requirements: (2018)

Welded Steel Anchors	<b>Pt 2, Ch 1, 301.</b> of the Rules - Normal and Higher Strength Hull Structural Steel
	<b>Pt 2, Ch 2, Sec 6</b> of the Rules - Approval of consumables for welding normal and higher strength hull structural steel
Cast Steel Anchors	<b>Pt 2, Ch 1, 501.</b> of the Rules - Hull and machinery steel castings
Anchor Shackles	<b>Pt 2, Ch 1, 601.</b> of the Rules - Hull and machinery steel forgings
	<b>Pt 2, Ch 1, 501.</b> of the Rules - Hull and machinery steel castings

- (1) The base steel grades in welded SHHP anchors are to be selected with respect to the material grade requirements for Class II of **Pt 3, Ch 1, 405.** of the Rules.
- (2) The welding consumables are to meet the toughness for the base steel grades in accordance with **Pt 2, Ch 2, Sec 6** of the Rules.
- (3) The toughness of the anchor shackles for SHHP anchors is to meet that for Grade 3 anchor chain in accordance with **Sec 4.**

#### **304. Constructions and dimensions (2017)**

1. The construction and form of anchors are to comply with a standard deemed appropriate by the Society(JIS etc.) or equivalent to this, the special forms of anchors are to be approved by the Society.
2. The high holding power anchors and super high holding anchors, except in accordance with the provision in the above **Par 1,** are to be tested by the holding power indicated by the Society and are to comply with the test requirements. **[See Guidance]**
3. Welded construction of fabricated anchors is to be done in accordance with procedures approved by the Society. Welding is to be carried out by qualified welders, following the approved welding procedures, using approved welding consumables.
4. Assembly and fitting are to be done in accordance with the design details. Securing of the anchor pin, shackle pin or swivel nut by welding is to be done in accordance with an approved procedure.

#### **305. Heat Treatment**

1. Components for cast or forged anchors are to properly heat treated in accordance with the requirements in **Pt 2. Ch 1** of the Rules.
2. The welding for rolled steel fabricated anchors may require stress relief after welding depending upon weld thickness. The manufacturers are to obtain approval by the Society in advance concerning stress relief after weld. Stress relief temperature are not to be exceed the tempering of the base material.

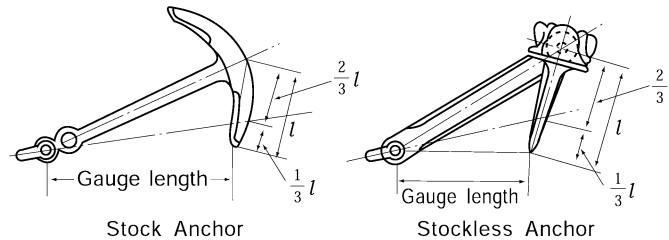
#### **306. Quality and Repair of Defects**

1. Anchors are to be free from cracks, notches, inclusions and other defects impairing the performance of the products.
2. Any necessary repairs to forged and cast anchors are to be agreed by the Surveyor and carried out in accordance with the repair criteria indicated in **Pt 2, Ch 1, 501.** and **601.** of the Rules. Repairs to fabricated anchors are to be agreed by the Surveyor and carried out in accordance with qualified weld procedures, by qualified welders, following the parameters of the welding procedures used in construction.

### 307. Dimensions and Forms

1. Length of the arm is as follows.

- (1) Length of the arm is the distance from the centre of the pin in case of anchors having the head pin and from the top of the crown in case of anchors of the other types to the tip of the flukes. (See **Fig 4.8.1**)
- (2) Where the crown is of concave form, the intersection of the centre line of the shank with the plane in contact with the top of the arms is considered as the top of the crown.



**Fig 4.8.1 Anchors**

2. Assembly and fitting of anchors are as follows unless specially approved by the Society.

- (1) The clearance either side of the shank within the shackle jaws is to be given in **Table 4.8.2** in accordance with the anchor mass.
- (2) The shackle pin is to be a push fit in the eyes of the shackle, which are to be chamfered on the outside to ensure a good tightness when the pin is clenched over on fitting. The shackle pin to hole tolerance is to be given in **Table 4.8.3** in accordance with diameter of the shackle pins.
- (3) The trunnion pin is to be a snug fit within the chamber and be long enough to prevent horizontal movement. The gap is to be no more than 1% of the chamber length.
- (4) The lateral movement of the shank is not exceed 3 degrees. (See **Fig 4.8.2**)

3. The dimensional inspections of anchors are to be performed by the manufacture. The manufacture is to show the data of measurement to the surveyor.

**Table 4.8.2 The clearance either side of the shank within the shackle jaws**

Anchor mass(t)	over	-	3	5	7
	up	3	5	7	-
Tolerance(mm)	up to	3	4	6	12

**Table 4.8.3 The shackle pin to hole tolerance**

The diameter of shackle pin(mm)	57 up	57 over
Hole tolerance(mm)	0.5 up	1.0 up

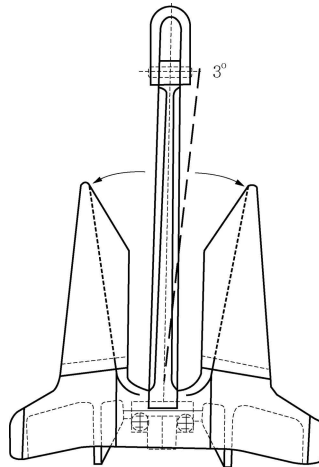


Fig 4.8.2 Allowable range of the lateral movement of the shank

**308. Mass**

1. The mass of the stock of a stock anchor is not to be less than one-fourth of the mass of anchor excluding stock.
2. The mass of stockless anchor excluding shank is not to be less than three-fifths of the total mass of the anchor.
3. The mass of the anchor is to exclude the mass of the swivel, unless this is an integral component.
4. The mass inspections of anchors are to be performed by the manufacture before executing proof test. The manufacture is to show the data of measurement to the surveyor.
5. In case of stock anchors, the mass of the anchor excluding stock and the mass of the stock are to be measured separately. In case of stockless anchors the total mass of anchor and the mass of shank are to be measured.

**309. Testing and certification**

**1. Test programme**

(1) The Society can request that either programme A or programme B be applied.

Programme A	Programme B
Drop test	Drop test
Hammering test	-
Proof load test	Proof load test
Visual inspection	Visual inspection
General NDE	General NDE
-	Extended NDE

(2) Applicable programmes for each product form are as follows.

Product test	Product form		
	Cast components	Forged components	Fabricated/Welded components
Programme A	O	X	X
Programme B <sup>(1)</sup>	O <sup>(2)</sup>	O	O

Notes

- (1) The Drop test requirement in Programme B is applicable for Cast Components.
- (2) CVN impact tests are to be carried out to demonstrate at least 27 joules average at 0°C

## 2. Drop and hammering tests

In case of test programme A, Cast steel anchors are to be subjected to the following tests prior to the execution of the proof tests and are to comply with the test requirements.

### (1) *Drop tests*

- (a) Each piece of the cast steel anchor is to be lifted to 4 m in height and dropped on an steel slab on the hard ground without any crack or other defects.
- (b) Where shank and arms are cast in one piece in stock anchors, the anchor is first to be lifted to the specified height with its shank and arms in a horizontal position and then dropped on the steel slab, and to be lifted once more to the specified height with the crown downwards and dropped on two steel blocks on the slab arranged to enable the anchor to give shock at the middle of each arm without making the crown touch the slab, and are to be found free from cracks, deformation or other defects.
- (c) Where the slab is broken by the impact, the anchor is to be retested with a new slab.

### (2) *Hammering tests*

After the drop test specified in (1), the anchor is to be slung clear of the ground and thoroughly hammered with a hammer which the mass is 3 kg and over, and is to be found free from cracks or other defects.

- (3) For fracture and unsoundness detected in a drop test or hammering test, repairs are not permitted and the components is to be rejected.

## 3. Proof tests

- (1) Anchors are to be tested in accordance with the requirements in **Table 4.8.4**, applying the required load corresponding to the mass of anchor (excluding the mass of stock for stock anchor) at the position of one-third of the length of the arm from the tip of the fluke, for every arm or for both arms simultaneously or for each position in case of the anchor having the head pin, and to be found free from cracks, deformation or other defects. In every test, the difference between the gauge lengths, where one-tenth of the required load was applied first and where the load has been released to one-tenth of the required load from the full load, may be permitted not to exceed 1 % of the gauge length. (See **Fig 4.8.1**)

On completion of the proof load tests the anchors made in more than one piece are to be examined for free rotation of their heads over the complete angle.

- (2) The proof test load, however, for high holding power anchors is to be the load specified for an ordinary anchor of which mass is equal to  $\frac{4}{3}$  times the actual total mass of high holding power anchor.
- (3) The proof test load for super high holding power anchors is to be the load specified for an ordinary anchor of which the mass is 2 times the actual mass of super high holding power anchor.

Table 4.8.4 Proof test load for anchors (2018)

Mass of anchor (kg)	Proof test load (kN)	Mass of anchor (kg)	Proof test load (kN)	Mass of anchor (kg)	Proof test load (kN)	Mass of anchor (kg)	Proof test load (kN)
25	12.6	1000	199	4500	622	10000	1010
30	14.5	1050	208	4600	631	10500	1040
35	16.9	1100	216	4700	638	11000	1070
40	19.1	1150	224	4800	645	11500	1090
45	21.2	1200	231	4900	653	12000	1110
50	23.2	1250	239	5000	661	12500	1130
55	25.2	1300	247	5100	669	13000	1160
60	27.1	1350	255	5200	677	13500	1180
65	28.9	1400	262	5300	685	14000	1210
70	30.7	1450	270	5400	691	14500	1230
75	32.4	1500	278	5500	699	15000	1260
80	33.9	1600	292	5600	706	15500	1270
90	36.3	1700	307	5700	713	16000	1300
100	39.1	1800	321	5800	721	16500	1330
120	44.3	1900	335	5900	728	17000	1360
140	49.0	2000	349	6000	735	17500	1390
160	53.3	2100	362	6100	740	18000	1410
180	57.4	2200	376	6200	747	18500	1440
200	61.3	2300	388	6300	754	19000	1470
225	65.8	2400	401	6400	760	19500	1490
250	70.4	2500	414	6500	767	20000	1520
275	74.9	2600	427	6600	773	21000	1570
300	79.5	2700	438	6700	779	22000	1620
325	84.1	2800	450	6800	786	23000	1670
350	88.8	2900	462	6900	794	24000	1720
375	93.4	3000	474	7000	804	25000	1770
400	97.9	3100	484	7200	818	26000	1800
425	103	3200	495	7400	832	27000	1850
450	107	3300	506	7600	845	28000	1900
475	112	3400	517	7800	861	29000	1940
500	116	3500	528	8000	877	30000	1990
550	124	3600	537	8200	892	31000	2030
600	132	3700	547	8400	908	32000	2070
650	140	3800	557	8600	922	34000	2160
700	149	3900	567	8800	936	36000	2250
750	158	4000	577	9000	949	38000	2330
800	166	4100	586	9200	961	40000	2410
850	175	4200	595	9400	975	42000	2490
900	182	4300	604	9600	987	44000	2570
950	191	4400	613	9800	998	46000	2650
						48000	2730

NOTE ;  
Where mass of anchor is intermediate in this Table, proof test load is to be determined by linear interpolation

#### 4. Visual inspection

After proof loading visual inspection of all accessible surfaces is to be carried out.

**5. General non-destructive examination**

- (1) For ordinary anchors and HHP anchors, after proof loading, general non-destructive examination is to be carried out as indicated in the following Table.

Location	Method of NDE
Feeders of castings	PT or MT
Risers of castings	PT or MT
Weld repairs	PT or MT
Forged components	Not required
Fabrication welds	PT or MT

- (2) For SHHP anchors, after proof loading, general non-destructive examination is to be carried out as indicated in the following Tables.

Location	Method of NDE
Feeders of castings	One of PT or MT and UT
Risers of castings	One of PT or MT and UT
All surfaces of castings	PT or MT
Weld repairs	One of PT or MT and UT (2018)
Forged components	Not required
Fabrication welds	PT or MT

At sections of high load or at suspect areas, the Society may impose volumetric non-destructive examination, e.g, ultrasonic inspection or radiographic inspection. (2018)

- (3) The NDE methods and acceptance criteria are to comply with the **Pt 2, Annex 2-2** and **Annex 2-7** of the Guidance relating to the Rules  
 (4) If defects are detected by non-destructive test, repairs are to be carried out in accordance with **306. 2**.

**6. Extended non-destructive examination**

- (1) In case of programme B, after proof loading, extended non-destructive examination is to be carried out as indicated in the following Table.

Location	Method of NDE
Feeders of castings	One of PT or MT and UT
Risers of castings	One of PT or MT and UT
All surfaces of castings	PT or MT
Random areas of castings	UT
Weld repairs	PT or MT
Forged components	Not required
Fabrication welds	PT or MT

- (2) The NDE methods and acceptance criteria are to comply with the **Pt 2, Annex 2-2** and **Annex 2-7** of the Guidance relating to the Rules  
 (3) If defects are detected by non-destructive test, repairs are to be carried out in accordance with

306. 2.

**310. Retests**

Where the result of the impact test is unsatisfactory, retest is to be in accordance with the requirements in **Pt 2, Ch 1, 109.** of the Rules.

**311. Marking**

1. Where anchors have satisfactorily passed the tests and inspections, they are to be stamped with the mass of anchor (excluding the mass of stock in stock anchors), at the middle position of the shank and the Society's brand and the test number at the position two-thirds of the length of arm from the tip of the fluke on the same side. Where the anchor is formed with separate shank and arms, the Society's brand and the test number are also to be stamped on the shank in the neighbourhood of the head pin, and in case of stock anchor, the mass of stock, the Society's brand and the test number are also to be stamped on the stock.
2. In case of high holding power anchors, alphabet H is to be stamped in front of the Society's brand in addition to the stamps specified in the above **Par 1.**
3. In case of super high holding power anchors, alphabet SH is to be stamped before the Society's brand in addition to the stamps specified in the above **Par 1.**

**312. Painting**

Anchors are not to be painted until the tests and inspections are finished.

## Section 4 Chains

**401. Applications** [See Guidance]

1. The materials, design, manufacture and testing of stud link anchor chain cables to be equipped on ships, shackles and swivels (hereinafter referred to as "accessories") are to comply with the requirements in this Section or to be of equivalent quality. Where, in exceptional cases, studless short link chain cables are used with the consent of this Society, they must comply with recognized national or international standards. Chafing chain for Emergency Towing Arrangements (ETA) are to be in accordance with the Guidance relating to the Rules specified by the Society.
2. Offshore mooring chains and chafing chain for Emergency Towing Arrangements (ETA) are to be in accordance with the Guidance relating to the Rules specified by the Society.

**402. Chain cable grades**

Depending on the nominal tensile strength of the chain cable steel used for manufacture, stud link chain cables are to be subdivided into Grades 1, 2 and 3.

**403. Materials**

1. Chains are to be made of the materials given in **Table 4.8.5** according to their grades and manufacturing processes, respectively.
2. The studs are to be made of steel corresponding to that of the chain or from rolled, cast or forged mild steels. The use of other materials, e.g. grey or nodular cast iron is not permitted.

Table 4.8.5 Mechanical properties of rolled steel bars

Chain cable grades	Materials Manufacturing Process	Materials for Chain Links <sup>(1)</sup>			Materials for Accessories <sup>(2)</sup>	
		Flash butt welded	Cast	Forged	Cast	Forged
Grade 1 chain	Grade 1 chain bar (RSBC 31)		-		Grade 2 cast steel for chain (RSCC 50)	Grade 2 steel forging for chain (RSFC 50)
Grade 2 chain	Grade 2 chain bar (RSBC 50)	Grade 2 cast steel for chain (RSCC 50)	Grade 2 steel forging for chain (RSFC 50)			
Grade 3 chain	Grade 3 chain bar (RSBC 70)	Grade 3 cast steel for chain (RSCC 70)	Grade 3 steel forging for chain (RSFC 70)	Grade 32 cast steel for chain (RSCC 70)	Grade 2 steel forging for chain (RSFC 70)	

NOTE :

<sup>(1)</sup> Materials for Grade 2 chains may be used for Grade 1 chains.

<sup>(2)</sup> Materials for Grade 2 chains may be used for accessories for Grade 2 chains.

#### 404. Design

- Chains and accessories must be designed according to a standard recognized by the Society, such as ISO 1704.
- There is to be an odd number of links in each length of chains, except where swivels are fitted.
- Where designs do not comply with this and where accessories are of welded construction, drawings giving full details of the design, the manufacturing process and the heat treatment are to be submitted to the Society for approval.
- Wire rope may be used in place of chain cable on ships with less than 40 m in length and subject to the following conditions: (2018)
  - The length of the wire rope is to be equal to 1.5 times the corresponding tabular length of chain cable (Table 4.8.1) and their strength is to be equal to that of tabular chain cable of Grade 1 (Table 4.8.8).
  - A short length of chain cable is to be fitted between the wire rope and anchor having a length of 12.5 m or the distance between anchor in stowed position and winch, whichever is less.
  - All surfaces being in contact with the wire need to be rounded with a radius of not less than 10 times the wire rope diameter (including stem).

#### 405. Manufacturing Process

- Chains should preferably be manufactured by flash butt welding using Grade 1, 2 or 3 bar material. Manufacture of the links by drop forging or castings is permitted. Their manufactures are to obtain approval by the Society in advance concerning their manufacturing methods.
- On request, pressure butt welding may also be approved for studless Grade 1 and 2 chain cables, provided that the nominal diameter of the chain cable does not exceed 26 mm.
- Studs are to be securely fastened by press fitting or welding with an approved procedure. Inserted studs are to be pressed completely to the centre position of the link and at right angles to the sides of the link and welding of studs is to satisfy the requirements specified in 408. of the Rules.
- Accessories such as shackles, swivels and swivel shackles are to be forged or cast in steel of at least Grade 2. The welded construction of these parts may also be approved.

#### 406. Heat treatment

1. According to the grade of steel, chains and accessories are to be supplied in one of the conditions specified in **Table 4.8.6**. However Grade 2 flash butt welded chains subjected to sufficient preheating may not be required heat treatment on the approval by the Society.
2. The heat treatment shall in every case be performed before the proof load test, the breaking load test, and all mechanical testing.

**Table 4.8.6 Condition of supply of chains and accessories**

Grade	Chains	Accessories
1	As welded or Normalized	NA
2	As welded or Normalized <sup>(1)</sup>	Normalized
3	Normalized, Normalized and tempered or Quenched and tempered	Normalized, Normalized and tempered or Quench and tempered
NOTE :		
<sup>(1)</sup> Grade 2 chain cables made by forging or casting are to be supplied in the normalized condition.		

#### 407. Quality and repair of defects

1. Chains and accessories must have a clean surface consistent with the method of manufacture and be free from cracks, notches, inclusions and other defects impairing the performance of the product. The flashes produced by upsetting or drop forging must be properly removed.
2. Minor surface defects other than preceding **Par 1**, can be partly removed by grinder. In this case the grinding is so as to leave gentle transition to the surrounding surface and, in principle, local grinding up to 5 % of the nominal link diameter may be permitted.
3. Permissible wear down of stud link chain cable for bower anchors

When a length of chain cable is so worn that the mean diameter of a link, at its most worn part, is reduced by 12 % or more from its required nominal diameter it is to be renewed.

The mean diameter is half the value of the sum of the minimum diameter found in one cross-section of the link and of the diameter measured in a perpendicular direction in the same cross-section. (2018)

#### 408. Welding of studs

The welding of studs is to be in accordance with an approved procedure subject to the following conditions:

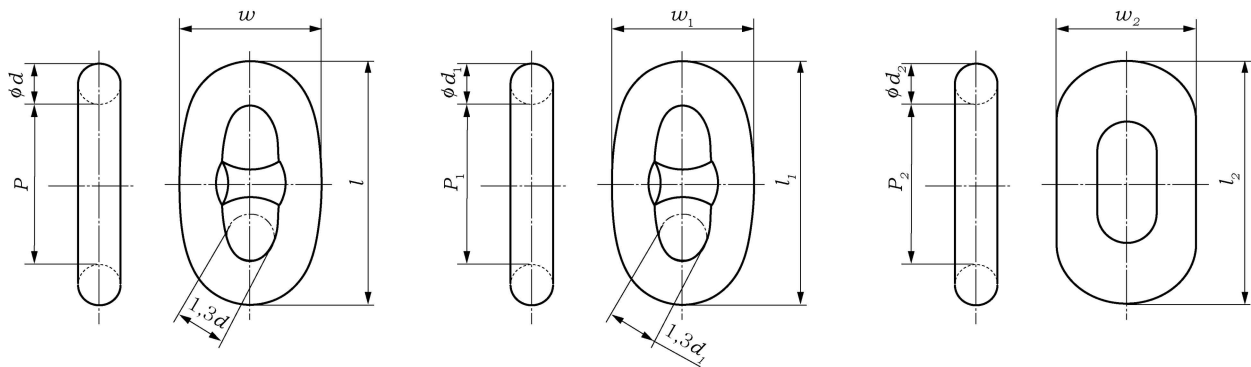
1. The studs must be of weldable steel
2. The studs are to be welded at one end only, i.e., opposite to the weldment of the link. The stud ends must fit the inside of the link without appreciable gap.
3. The welds, preferably in the flat position, shall be executed by qualified welders using suitable welding consumables.
4. All welds must be carried out before the final heat treatment of the chain cable.
5. The welds must be free from defects liable to impair the proper use of the chain. Under-cuts, end craters and similar defects shall, where necessary, be ground off.

#### 409. Shape and proportions

1. The shape and proportions of links and accessories must conform to a recognized standard, such as ISO 1704 or the designs specially approved, and are generally to be as given in **Fig 4.8.3**. and

4.8.4. [See Guidance]

2. The nominal diameter of chains is to be denoted by the diameter of the common link.
3. One length of chains is the distance from the outer end of the internal bent portion of the link at one end of the chain to that at the other end of the chain. The standard length of anchor chains is 27.5 m.
4. Links of every kind, shackles and swivels are to be of uniform shape and their bent portions are to be sufficient to allow each link to work smoothly.



$d$  = nominal diameter of common link

$$l = 6 d$$

$$p = 4 d$$

$$w \approx 3.6 d$$

(a) Common link

$d$  = nominal diameter of common link

$d_1$  = diameter of enlarged link  $\approx 1.1d$

$$l_1 = 6 d_1$$

$$p_1 = 4 d_1$$

$$w_1 \approx 3.6 d_1$$

(b) Enlarged link

$d$  = nominal diameter of common link

$d_2$  = diameter of end link  $\approx 1.2d$

$$l_2 = p_2 + 2d_2 \approx 6.75d$$

$$p_2 = 4.35 d$$

$$w_2 \approx 4 d$$

(c) End link

**Fig 4.8.3 Shape and proportions of links**

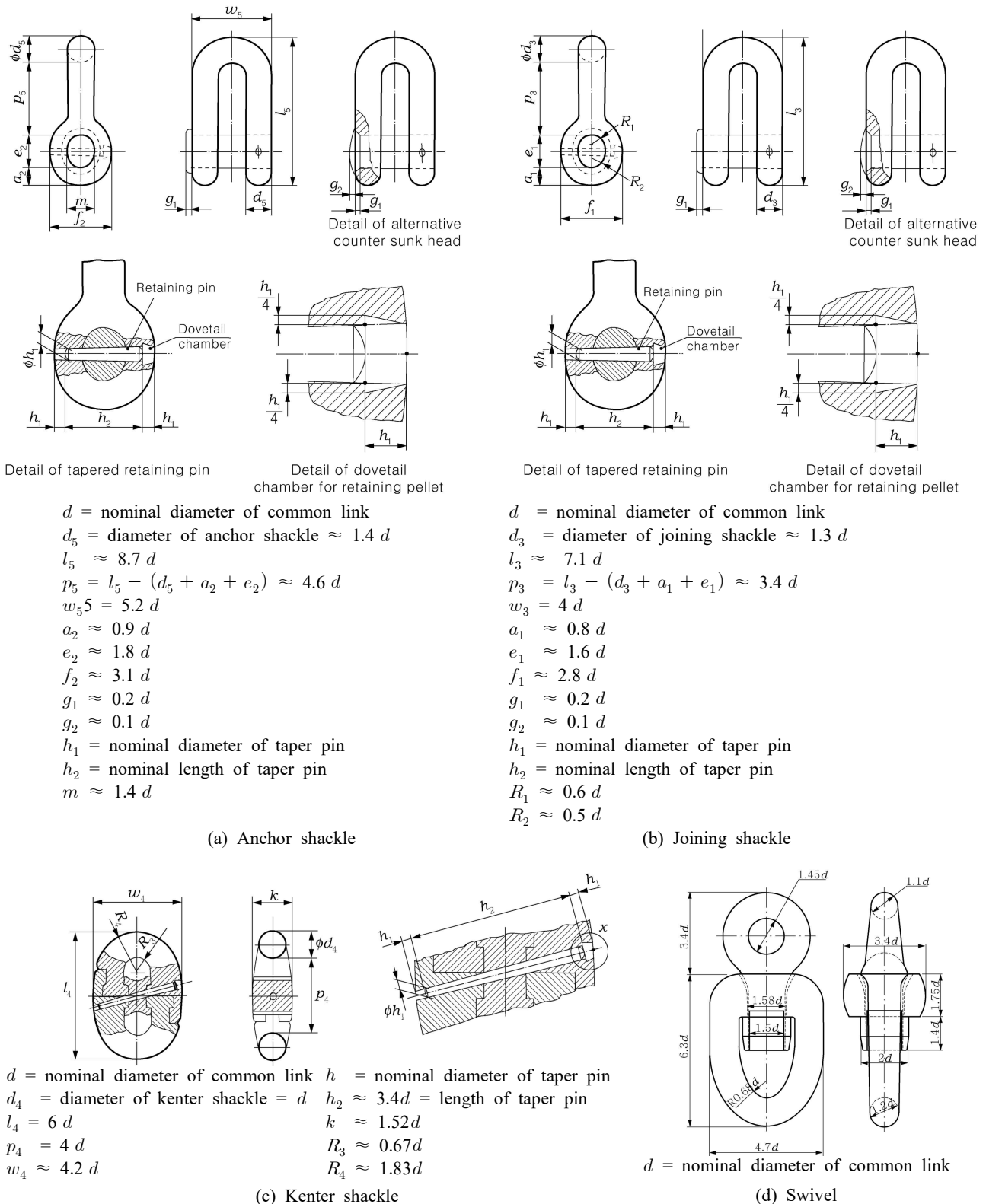


Fig 4.8.4 Shape and proportions of accessories

#### 410. Dimension tolerances

The tolerances for chains and accessories are to comply with the following requirements in **Par 1** and **2** and the dimensions thereof are to be measured after the execution of a proof test.

##### 1. Chain

- (1) ~ (2) <same as the present Rules>
- (3) The maximum allowable tolerance on assembly measured over a length of 5 links are to be  $\pm 2.5\%$ , but not to be negative (measured with the chain under tension after proof load test), the length of 5 links is based on the distance from the outer end of the internal bent portion of the link at one end of the chain to that at the other end of the chain. (2019)

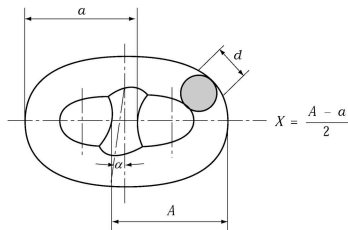


Fig 4.8.5 the position of studs

Table 4.8.7 Negative tolerances of diameters

Nominal Diameter (mm)	over		40	84	122
	up to	40	84	122	
Negative Tolerances (mm)		1	2	3	4

- (2) The tolerances other than the crown part of each kind of link are to be up to  $+5\%$  of the nominal diameter, but are not to be negative. The approved manufacturer's specification is applicable to the plus tolerance of the diameter at the flush-butt weld.
- (3) The maximum allowable tolerance on assembly measured over a length of 5 links are to be  $\pm 2.5\%$ , but not to be negative (measured with the chain under tension after proof load test)
- (4) The tolerances except for the requirements specified in (1) to (3) above are to be  $\pm 2.5\%$ .
- (5) The tolerances of stud positions are to comply with the standard as follows, except the final link at each end of one length of chain.
  - (A) Maximum off-centre distance X :  $10\%$  of the nominal diameter (d)
  - (B) Maximum deviation "alpha" from the  $90^\circ$  position :  $4^\circ$
 where, X and alpha are as specified in **Fig 4.8.5**.

##### 2. Accessories

The tolerance of the diameter at the bent portions of center shackles are to be equal  $+5\%$ , but may not be negative. All other dimensions are subjected to manufacturing tolerances of  $\pm 2.5\%$

411. Mass

The mass of chains is to comply with the standard mass given in **Table 4.8.8** in accordance with their kind, and to be measured after the execution of proof tests.

**Table 4.8.8 Breaking and proof test loads for chains**

Nominal dia. <i>d</i> (mm)	Grade 1 chain		Grade 2 chain		Grade 3 chain		Mass of chain per metre (kg)
	Breaking test load (kN)	Proof test load (kN)	Breaking test load (kN)	Proof test load (kN)	Breaking test load (kN)	Proof test load (kN)	
12.5	66	46	92	66	132	92	3.422
14	82	58	115	82	165	115	4.292
16	107	75	150	107	215	150	5.606
17.5	128	89	179	128	256	179	6.707
19	150	105	211	150	301	211	7.906
20.5	175	123	244	175	349	244	9.203
22	200	140	280	200	401	280	10.60
24	237	167	332	237	476	332	12.61
26	278	194	389	278	556	389	14.80
28	321	225	449	321	642	449	17.17
30	368	257	514	368	735	514	19.71
32	417	291	583	417	833	583	22.43
34	468	328	655	468	937	655	25.32
36	523	366	732	523	1050	732	28.38
38	581	406	812	581	1160	812	31.62
40	640	448	896	640	1280	896	35.04
42	703	492	981	703	1400	981	38.63
44	769	538	1080	769	1540	1080	42.40
46	837	585	1170	837	1680	1170	46.34
48	908	635	1270	908	1810	1270	50.46
50	981	686	1370	981	1960	1370	54.75
52	1060	739	1480	1060	2110	1480	59.22
54	1140	794	1590	1140	2270	1590	63.86
56	1220	851	1710	1220	2430	1710	68.68
58	1290	909	1810	1290	2600	1810	73.67
60	1380	969	1940	1380	2770	1940	78.84
62	1470	1030	2060	1470	2940	2060	84.18
64	1560	1100	2190	1560	3130	2190	89.70
66	1660	1160	2310	1660	3300	2310	95.40
68	1750	1230	2450	1750	3500	2450	101.3
70	1840	1290	2580	1840	3690	2580	107.3
73	1990	1390	2790	1990	3990	2790	116.7
76	2150	1500	3010	2150	4300	3010	126.5
78	2260	1580	3160	2260	4500	3160	133.2
81	2410	1690	3380	2410	4820	3380	143.7
84	2580	1800	3610	2580	5160	3610	154.5
87	2750	1920	3850	2750	5500	3850	165.8
90	2920	2050	4090	2920	5840	4090	177.4
92	3040	2130	4260	3040	6080	4260	185.4
95	3230	2260	4510	3230	6440	4510	197.6
97	3340	2340	4680	3340	6690	4680	206.1
98	3407	2382	4768	3407	6810	4768	210.3
100	3530	2470	4940	3530	7060	4940	219.0
102	3660	2560	5120	3660	7320	5120	227.8
105	3850	2700	5390	3850	7700	5390	241.4
107	3980	2790	5570	3980	7960	5570	250.7
108	4046	2829	5663	4046	8088	5663	255.4

Table 4.8.8 Breaking and proof test loads for chains (continued)

Nominal dia. <i>d</i> (mm)	Grade 1 chain		Grade 2 chain		Grade 3 chain		Mass of chain per metre (kg)
	Breaking test load (kN))	Proof test load (kN)	Breaking test load (kN)	Proof test load (kN)	Breaking test load (kN)	Proof test load (kN)	
111	4250	2970	5940	4250	8480	5940	269.8
114	4440	3110	6230	4440	8890	6230	284.6
117	4650	3260	6510	4650	9300	6510	299.8
120	4850	3400	6810	4850	9720	6810	315.4
122	5000	3500	7000	5000	9990	7000	326.0
124	5140	3600	7200	5140	10280	7200	336.7
127	5350	3750	7490	5350	10710	7490	353.2
130	5570	3900	7800	5570	11140	7800	370.1
132	5720	4000	8000	5720	11420	8000	381.6
137	6080	4260	8510	6080	12160	8510	411.0
142	6450	4520	9030	6450	12910	9030	441.6
147	6840	4790	9560	6840	13660	9560	473.2
152	7220	5050	10100	7220	14430	10100	506.0
157	7600	5320	10640	7600	15200	10640	539.8
162	7990	5590	11170	7990	15970	11170	574.7

NOTE :

Where nominal diameter is less than 12.5 mm or intermediate in this Table, breaking test loads, proof test loads and mass of chain per metre are to be determined by the following table :

Kind	Breaking test load (kN)	Proof test load (kN)	Mass (kg)
Grade 1 chain	$0.00981d^2 (44 - 0.08d)$	$0.00686d^2 (44 - 0.08d)$	$0.0219d^2$
Grade 2 chain	$0.01373d^2 (44 - 0.08d)$	$0.00981d^2 (44 - 0.08d)$	$0.0219d^2$
Grade 3 chain	$0.01961d^2 (44 - 0.08d)$	$0.01373d^2 (44 - 0.08d)$	$0.0219d^2$

where :

*d* = Nominal diameter (mm)

## 412. Test and inspection of chain

### 1. General

- (1) Finished chain cables are to be subjected to the proof load test and the breaking load test in the presence of the Surveyor, and shall not fracture or exhibit cracking.
- (2) Special attention is to be given to the visual inspection of the flash-butt weld, if present. For this purpose, the chain cables must be free from paint and anti-corrosion media.

### 2. Breaking load tests [See Guidance]

- (1) For the breaking load test, one sample comprising at least of three links is to be taken from every four lengths or fraction of chain cables. However, where one length of chain is short and the total length of two lengths of chain is less than 27.5 metres, such two lengths may be regarded as one length.
- (2) The test specimens are to withstand satisfactorily the breaking test loads specified in **Table 4.8.8** according to their grades. The breaking load is to be maintained for a minimum of 30 seconds
- (3) Where the capacity of the testing machine does not reach the breaking test loads specified in **Table 4.8.8**, the breaking test may be substituted by a method approved by the Society.
- (4) The links concerned shall be made in a single manufacturing cycle together with the chain cable and must be welded and heat treated together with it. Only after this they may be separated from the chain cable in the presence of the Surveyor.

### 3. Proof load tests

The proof tests are to be carried out for each length of the chains which satisfactorily complied with the breaking tests, and the chains are to withstand the proof test loads specified in **Table 4.8.8** without cracking, breakage or any other defects. The test is to be carried out after the chains were heat treated where necessary.

### 4. Retest

#### (1) Breaking load tests

(A) Where the test is not satisfactory, the chain may be retested by taking out another set of test specimens from the same length of chain, and where the test specimens comply with the requirements, the remaining three lengths of chain may be accepted. Where the retest fails, the length of chain from which the test specimen have been taken is rejected, and the remaining three chains are to be subjected to the breaking tests individually. If one of such test fails to meet the requirements, all the remaining three lengths of the chain are rejected.

(B) Where the missing chain links due to the preparation of the retest of **Par 5** above are replaced by new chain links, the test specimens manufactured by the same procedure are to be subjected to the breaking test, and are to comply with the requirements.

#### (2) Proof load tests

Where the test is not satisfactory, the chain may be retested only once more by link of same manufacturing process after replacing the defective link. Where, however, more than 5 % of the total links are found defective, the retest is not permitted. In addition, an investigation is to be made to identify the cause of the failure.

### 5. Mechanical tests on grade 2 and 3 chain cable

(1) Grade 2 and grade 3 chain cables are to be subjected to the mechanical tests, and are to comply with the requirements.

(2) Mechanical test specimens are to be taken from every four lengths in accordance with **Table 4.8.9**. For forged or cast chain cables where the batch size is less than four lengths, the sampling frequency will be by heat and heat treatment charge.

(3) An additional link (or where the links are small, several links) for mechanical test specimen removal is (are) to be provided in a length of chain cable not containing the specimen for the breaking test. The specimen link must be manufactured and heat treated together with the length of chain cable. Mechanical tests are to be carried out in the presence of the Surveyor.

Mechanical properties of chain links are to comply with requirements given in **Table 4.8.10**.

(4) Test procedure and forms of test specimens are to comply with the requirements in **Pt 2, Ch 1, Sec 2** of the Rules.

(5) Where the test results of mechanical properties of chain links do not conform to the requirements, additional tests are to be carried out in accordance with the requirements specified in **Pt 2, Ch 1, 306. 9** of the Rules.

## 413. Test and inspection of accessories

### 1. Proof load test

Each kind of accessory is to be tested to the proof test loads specified in **Table 4.8.8**, in accordance with the kinds and diameters of the chains to be connected therewith, and they are to withstand the test without crack, breakage or any other defect. This test may be carried out simultaneously with the proof test for the chains or together with any chains of the same diameter with which shackles and swivels are connected.

### 2. Breaking load test

(1) From each manufacturing batch (same accessory type, grade, size and heat treatment charge, but not necessarily representative of each heat of steel or individual purchase order) of 25 units or less of detachable links, shackles, swivels, swivel shackles, enlarged links, and end links, and from each manufacturing batch of 50 units or less of kenter shackles, one unit is to be subjected to the breaking load test at the break load specified for the corresponding chain given by **Table 4.8.8**. Enlarged links and end links need not be tested provided that they are manufactured and heat treated together with the chain cable.

(2) Where the test of Par (1) above is not satisfactory, the accessories may be retested by taking

- out two units from the same lot. If one such test fails to meet the requirements, the entire unit test quantity is rejected.
- (3) Accessories used for the breaking load test must not be put into further use. However, the accessories, which have been successfully tested in accordance with Par (1) of the above and are manufactured with the following (A) or (B) may be used in service at the discretion of the Society.
    - (A) the material having higher strength characteristics than those specified for the part in question (e.g. grade 3 materials for accessories for grade 2 chain).
    - (B) the same grade materials as the chain but with increased dimensions subject to the successful procedure tests that such accessories are so designed that the breaking strength is not less than 1.4 times the breaking load of the chain which they are intended
  - (4) When the accessories are in accordance with the following requirements in (A) to (C), no breaking load test is required subject to the approval by the Society. **[See Guidance]**
    - (A) The breaking load test has been demonstrated on the occasion of the approval testing of parts of the same design.
    - (B) The tensile test and impact test have been demonstrated by each manufacturing lot.
    - (C) Non-destructive testing has been demonstrated before forwarding the products.

**3. Mechanical properties and tests**

- (1) Unless otherwise specified, the forging or casting must at least comply with the mechanical properties given in **Table 4.8.10**, when properly heat treated. For test sampling, forgings or castings of similar dimensions originating from the same heat treatment charge and the same heat of steel are to be combined into one test unit.
- (2) Mechanical tests are to be carried out in the presence of the Surveyor depending on the type and grade of material used. From each test unit, one tensile test specimen and three Charpy V-notch impact test specimens are to be taken in accordance with **Table 4.8.9**.
- (3) Test procedure and forms of test specimens are to comply with the requirements in **Pt 2, Ch 1, Sec 2** of the Rules.
- (4) Where the test results do not conform to the requirements, additional tests are to be carried out in accordance with the requirements specified in **Pt 2, Ch 1, 306. 9** of the Rules.

**Table 4.8.9 Number of mechanical test specimens for finished chain cables and accessories**

Grade	Manufacturing method	Condition of supply	Number of test specimens		
			Tensile test for base metal	Charpy V-notch impact test	
				Base metal	Weldment
2	Flush-butt welded	As welded	1	3	3
		Normalized	-	-	-
	Forged or Cast	Normalized	1	3 <sup>(1)</sup>	-
3	Flush-butt welded	Normalized, Normalized and tempered, Quenched and tempered	1	3	3
	Forged or Cast	Normalized, Normalized and tempered, Quenched and tempered	1	3	-

NOTE :

<sup>(1)</sup> For chain cables, Charpy V-notch impact test is not required.

Table 4.8.10 Mechanical properties of finished chain cables and accessories

Grade	Tensile test				Impact test <sup>(1)(2)(3)</sup>		
	Yield point or proof stress (N/mm <sup>2</sup> )	Tensile strength (N/mm <sup>2</sup> )	Elongation (L = 5d) (%)	Reduction of area (%)	Testing temperature (°C)	Minimum mean absorbed energy(J)	
						Base Metal	Weldment
2	295 min.	490~690	22 min.	-	0	27	27
3	410 min.	690 min.	17 min.	40 min.	0	60	50

NOTE :

- (1) When the absorbed energy of two or more test specimens among a set of test specimens is less in value than the specified minimum mean absorbed energy or when the absorbed energy of a single test specimen is less in value than 70 % of the specified minimum mean absorbed energy, the test is considered to have failed.
- (2) For grade 3 chain, impact test can be carried out at -20°C with the consent of the Society. The minimum mean absorbed energy to be not less than 27 J for weldment and 35 J for base metal
- (3) For Grade 2 chain heat treated, no impact testing is required.

#### 414. Marking and certification

##### 1. Marking

Where chains and accessories have satisfactorily passed the tests and inspections, they are to be stamped with the Society's brand, kind of chain and certificated numbers. Chain cables which meet the requirements are to be stamped at both ends of each length at least with the following marks; cf. Fig 4.8.6.

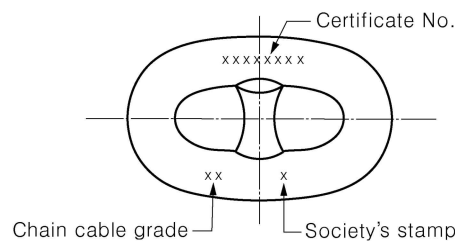


Fig 4.8.6 Marking of chain cables

##### 2. certification

chains and accessories which meet the requirements are to be certified by the Society at least with the following items:

- Manufacturer's name
- Grade
- Chemical composition (including total aluminum content)
- Nominal diameter/weight
- Proof/break loads
- Heat treatment
- Marks applied to chain
- Length
- Mechanical properties, where applicable

#### 415. Painting

Chains and accessories are not to be painted until the tests and inspections are finished.

## Section 5 Steel Wire Ropes








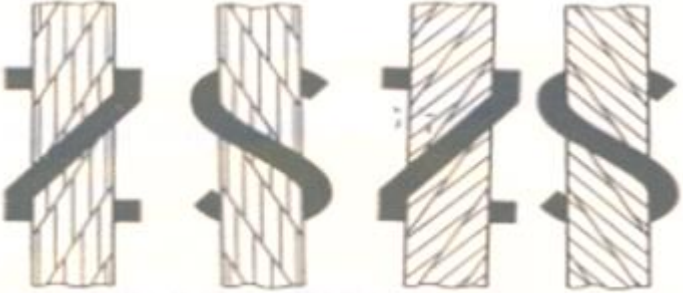
### 501. Application

1. The steel wire ropes used for steering ropes, mast riggings, stream wires, tow lines or mooring lines (hereinafter referred to as "steel wire rope") to be equipped on ships in accordance with the provisions in **Sec 2** are to comply with the requirements in this Section or to be of equivalent quality.
2. The provisions in this Section are applicable to the wire ropes constructed with fibre rope core and from individual wires having the tensile strength level of  $1470 \text{ N/mm}^2$  [ $150 \text{ kgf/mm}^2$ ]. However, wire ropes constructed from other individual wires than those described above or steel wire ropes constructed with an independent wire rope core may be used where specially approved in connection with their manufacture.

### 502. Kinds

1. Steel wire ropes are classified by Composition, lay direction as specified in **Table 4.8.11**.
2. Generally, steel wire ropes having a great number of individual wires are used for running riggings since they provide more flexibility while ropes with fewer individual wires are used for standing riggings since they provide less elongation and greater wear-resistant.

**Table 4.8.11 Designation system, Composition Mark, Sectional view of steel wire ropes**

Designation system	7wires 6strands	12wires 6strands	19wires 6strands	24wires 6strands	30wires 6strands	37wires 6strands	Warrington seals 36wires 6strands
Composition mark	6 × 7	6 × 12	6 × 19	6 × 24	6 × 30	6 × 37	6 × WS(36)
Sectional view							
Lay direction							
	Ordinary Z twisting(O/Z)   Ordinary S twisting(O/S)   Lang Z twisting(L/Z)   Lang S twisting(L/S)						

### 503. Processes of manufacture

1. The individual wires composing the strands of steel wire ropes are to consist of wires of KS D 3559 (hard steel wires) or equivalent thereto or heat treated materials.
2. The individual wires are to have no joint for the whole length of a steel wire rope. However, in an unavoidable case in the manufacturing process, they may be jointed by welding, brazing or twisting at only one position for each 10 metre length of strand.
3. The individual wires are to be galvanized after being drawn or to be drawn after being galvanized.
4. Synthetic fabrics or natural fibres of good quality which suitably contains grease are to be used for

fibre core of steel wire ropes and strands. The grease is to be free from acid or heavy alkali.

5. Steel wire ropes are to be left-hand lay and the strands are to be right-hand lay (called as "ordinary Z twisting").
6. Diameter, degree of twist, etc. are to be finished uniformly for the whole length of the steel wire ropes.
7. If not specified, basically grease is to be applied to steel wire rope.

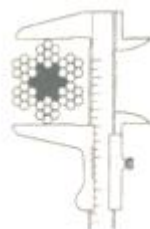
#### 504. Diameter of individual wires and steel wire ropes

1. The measuring result of the individual wires composing the strand of steel wire ropes is not to exceed the limits given in **Table 4.8.12**. (2019)

**Table 4.8.12 Permissible variation in diameter of individual wires (2019)**

Nominal diameter of individual wire (mm)	Difference between maximum and minimum diameters (mm)
$0.20 < d \leq 1.00$	0.06
$1.00 < d \leq 2.24$	0.09
$2.24 < d \leq 3.75$	0.12
$3.75 < d \leq 4.50$	0.14

2. The diameter of steel wire ropes is the diameter of the circumscribed circle of ropes; cf. **Fig 4.8.7** and it is taken as an average diameter measured at any two or more positions except within 1.5 metres from the ends of ropes. In this case, the tolerance for the diameter less than 10 mm of ropes is to be within +10 % and 0 %, the tolerance for the diameter more than 10mm of ropes is to be within +7 % and 0 %.



**Fig 4.8.7 How to measure diameter of steel wire ropes**

#### 505. Mass

The mass of steel wire ropes is as given in **Table 4.8.13** according to the kind and diameter for the reference.

#### 506. Breaking tests

1. Steel wire ropes are to be subjected to the breaking tests for each one length.
2. Where steel wire ropes are continuously manufactured by the same machine with the same wires and divided into several lengths, the test may be carried out on one length selected by the Surveyor at random. Where this test is satisfactory, the tests for the other lengths may be dispensed with.
3. The tests for steel wire ropes are to be carried out in accordance with the follows:
  - (1) Diameters and finished construction

- (A) Diameter of steel wire ropes is to satisfy 504.
- (B) Through the entire length, wire ropes should be free from defects such as dent, scratch which are detrimental to practical use.
- (2) Breaking load tests
  - (A) The test piece of which both ends are either loosened and solidified to cone with suitable metal alloy or gripped by other suitable methods, is to be set to the testing machine and gradually pulled until breaks down.
  - (B) One test piece is to be taken from each length of steel wire ropes.
  - (C) The distance between the grips is taken table below. However, in case of exceeding 2 metres, the distance between the grips should be 2 metres.

Diameter of steel wire ropes	The distance between the grips
up to 6 mm	not less than 300 mm
over 6 mm 20 mm or less	not less than 600 mm
20 mm over	not less than 30 times of diameter of steel wire ropes

- (D) The test pieces are to withstand the breaking test loads specified in **Table 4.8.13** according to the grade and diameter of steel wire rope.
- (E) Where the test piece has broken down at the parts of the grips before reaching the required breaking load, one more test piece taken from the steel wire rope may be retested.

Table 4.8.13 Masses and breaking test loads for steel wire ropes [See Guidance]

Composition mark	6 × 7		6 × 12		6 × 19		6 × 24		6 × 30		6 × 37		6 × WS(36)		
	Diameter of steel wire rope (mm)	Breaking test load (kN)	Mass per metre in length (kg)	Breaking test load (kN)	Mass per metre in length (kg)	Breaking test load (kN)	Mass per metre in length (kg)	Breaking test load (kN)	Mass per metre in length (kg)	Breaking test load (kN)	Mass per metre in length (kg)	Breaking test load (kN)	Mass per metre in length (kg)	Breaking test load (kN)	Mass per metre in length (kg)
3.15	5.24	0.037													
4	8.45	0.059	5.22	0.044	8.03	0.058									
5	13.2	0.093	8.15	0.068	12.5	0.091									
6.3	21.0	0.147	12.9	0.108	19.9	0.144					19.6	0.143			
8	33.8	0.237	20.9	0.175	32.1	0.233	29.3	0.212			31.6	0.230	32.3	0.253	
9	42.8	0.300	26.4	0.221	40.7	0.295	37.1	0.269			40.0	0.291	40.9	0.321	
10	52.8	0.371	32.6	0.273	50.2	0.364	45.8	0.332			49.4	0.359	50.4	0.396	
11.2	66.2	0.465	40.9	0.343	63.0	0.457	57.4	0.416			61.9	0.451	63.3	0.496	
12	-	-	-	-	72.3	0.524	65.9	0.478			71.1	0.517	-	-	
12.5	82.5	0.580	50.9	0.427	78.4	0.569	71.5	0.519			77.1	0.561	78.8	0.618	
14	103	0.727	63.9	0.535	98.4	0.713	89.7	0.651			96.7	0.704	98.9	0.776	
16	135	0.950	83.5	0.699	128	0.932	117	0.850			126	0.920	129	1.01	
18	171	1.20	106	0.885	163	1.18	148	1.08			160	1.16	163	1.28	
20	211	1.48	130	1.09	201	1.46	183	1.33			197	1.44	202	1.58	
22.4	265	1.86	164	1.37	252	1.83	230	1.67			248	1.80	253	1.99	
24	-	-			-	-	264	1.91			284	2.07	-	-	
25	330	2.32			314	2.28	286	2.08	256	1.94	308	2.25	315	2.47	
28	414	2.91			393	2.85	359	2.60	322	2.43	387	2.82	396	3.10	
30	475	3.34			452	3.28	412	2.99	369	2.79	444	3.23	454	3.56	
31.5	524	3.68					454	3.29	407	3.07	490	3.57	501	3.93	
33.5	592	4.16					514	3.73	460	3.47	554	4.03	566	4.44	
35.5	665	4.67					577	4.18	517	3.90	622	4.53	636	4.99	
37.5	742	5.22					644	4.67	577	4.35	694	5.05	709	5.57	
40	845	5.93					732	5.31	656	4.95	790	5.75	807	6.33	
42.5							827	6.00			892	6.49	911	7.15	
45							927	6.72			1000	7.28	1020	8.01	
47.5							1030	7.49			1110	8.11	1140	8.93	
50							1140	8.30			1230	8.98	1260	9.90	
53											1390	10.1	1420	11.1	
56											1550	11.3	1580	12.4	
60											1780	12.9	1820	14.2	
63											1960	14.3			

NOTES:

(1) The diameter of steel wire ropes not included in Table 4.8.13 may be in accordance with the Guidance relating to the Rules specified by the Society.

507. Individual wire tests

- Individual wire tests are to be carried out each one length.
- Where steel wire ropes are continuously manufactured by the same machine with the same wires and divided into selected lengths, the test may be carried out on one length selected by the Surveyor at random. Where this test is satisfactory, the tests for the other lengths may be dispensed with.
- For tests on the individual wires, a suitable length of a strand is to be cut off the rope and unstranded. The number of wires to be taken therefrom for tests is to be as specified in Table 4.8.14.(except for the core of the strand) Any straightening of test pieces which may be needed is to be done at the room temperature by a suitable method without injuring the test pieces.

4. In each of the individual wire tests, if some parts of the test results do not meet the requirements and the number of failed test pieces is not more than permissible number of failed test pieces given in **Table 4.8.15**, it may be considered as passed the tests. (except for Mass of Zinc Coating)

**Table 4.8.14** Number of test pieces for individual wires tests

Composition mark	Number of test Pieces
6 × 7	3
6 × 12	6
6 × 19	6
6 × 24	8
6 × 30	10
6 × 37	12
6 × WS (36)	19

**Table 4.8.15** Permissible number of failed test pieces in individual wire test

Composition mark	Permissible number of failed test pieces
6 × 7	0
6 × 12	1
6 × 19	1
6 × 24	1
6 × 30	1
6 × 37	1
6 × WS (36)	2

5. The individual wire tests are to be carried out in accordance with the following requirements:

- (1) Inspection of diameter and appearance
  - (A) Diameter of individual wire is to meet the requirement specified in **504**.
  - (B) The full length of individual wire, very smooth at its surface and circular at the cross section, shall have no detrimental defects even for a scratch when use.
- (2) Breaking tests
  - (A) The distance between grips is to be 100 mm where the diameter of test piece is less than 1.0 mm, or 200 mm where the diameter of test piece is 1.0 mm and over.
  - (B) The test piece is to be set to the testing machine and gradually pulled until broken down. The difference between individual breaking load and average value is to be within ±8 %.
  - (C) Where the test piece has broken down at the parts of the grips before reaching the required breaking load, one more test piece taken from the steel wire rope may be retested.
- (3) Twisting Tests
  - (A) In twisting tests, the test piece with the length 100 times the diameter of the test piece is to be gripped hard at the ends, and then one end is to be revolved in twisting speed specified in **Table 4.8.16** until the test piece is broken down. The number of twisting is to be not less than minimum number of twisting specified in **Table 4.8.16**.

**Table 4.8.16** Number of minimum twisting

Diameter of individual wire (mm)	Number of minimum twisting
$0.20 \leq d \leq 1.00$	21
$1.00 < d \leq 2.24$	20
$2.24 < d \leq 3.75$	18
$3.75 < d \leq 4.50$	17

NOTES:

1. Where it is necessary to modify the interval of the grips, the number of times of twisting is to be increased or decreased in direct proportion to the interval of the grips.
2. Twisting speed of individual wires is to be as table below.

Diameter of individual wire (mm)	Twisting speed(1 rpm)
$0.20 \leq d \leq 1.00$	up to 180
$1.00 < d \leq 3.60$	up to 60
$3.60 < d \leq 4.50$	up to 30

- (B) Where the test piece has been broken down at the parts of the grips, and the results of the test do not comply with minimum number of twisting of the requirements, one more test piece taken from the steel wire rope may be retested.
- (4) Wrapping Tests
- (A) The test pieces are to be wrapped at least eight times around the wire with the same diameter as the test piece. Where they are unwrapped, the number of broken test pieces is to be measured.

**508. Inspection**

Steel wire ropes will be accepted, where the results of the breaking and individual wire tests and the inspection of the dimensions and appearance of each length are satisfactory.

**509. Marking**

The steel wire ropes which have satisfactorily passed the tests and inspections are to be sealed with lead and affixed with the Society's brand, the test number and grade number on the lead.

**Section 6 Fibre Ropes**

**601. Application**

1. Hemp ropes and synthetic fibre ropes used for tow lines and mooring lines to be equipped on ships in accordance with the provisions in **Sec 2** (hereinafter referred to as "fibre rope") are to comply with the requirements in this Section.
2. Filaments and fibre ropes having characteristics differing from those specified in this Section are to comply with the requirements in **101. 3**.

**602. Kinds of fibre ropes**

Fibre ropes are classified into 9 kinds as shown in **Table 4.8.17**.

**Table 4.8.17 Kinds of fibre rope**

Kind of fibre rope			Filament (material)
Hemp rope			Manila hemp
Synthetic fibre rope	Vinylon rope	Grade 1 Grade 2	Vinylon
	Polyethylene rope	Grade 1 Grade 2	Polyethylene
	Polyester rope		Polyester
	Polypropylene rope	Grade 1 Grade 2	Polypropylene
	Polyamide rope		Polyamide

**603. Processes of manufacture**

Synthetic fibre ropes are to be manufactured by approved processes at approved works.

**604. Materials**

1. Hemp ropes are to be made of pure manila hemp not containing any other similar fibre.
2. Synthetic fibre ropes are to be made of pure filaments not containing any other filaments, which are not to be restored.

### 605. Construction of fibre ropes and others

1. Hemp ropes are, in general, to be composed of three strands and synthetic fibre ropes are to be composed of three or eight strands.
2. Three strand ropes are, in general, to be made of strands twisted together with a *Z* lay, these strands themselves being made with an *S* lay. Eight strand ropes are, in general, to be formed of four pairs of strands, the pairs being constituted successively of two strands twisted in the *S* direction and than of two strands twisted in the *Z* direction.
3. The number of the yarns of a strand is to be same, and the dimensions and laying of the yarns composing ropes are to be uniform for the whole length of the rope.
4. The lead for the strand is, in general, to be below 3.2 times the nominal diameter for three strand rope and below 3.5 times the nominal diameter for eight strand rope.
5. Polyamide ropes are to be suitably heat treated by induction furnace or others to set the lay and obtain dimensional stability. Vinylon and polypropylene ropes may be subjected to suitable heat treatment, if necessary.
6. Synthetic fibre ropes may be subjected to resin treatment and dye treatment subject to the approval by the Society.
7. Oil of good quality is to be used in manufacturing hemp ropes. Ropes are not to contain excessive quantity of oil.

### 606. Diameter

The diameter of fibre ropes is to be measured on circumscribed circle of the ropes under the load equal to 5 % of the breaking test load specified in **Table 4.8.18**. Its tolerance is to be  $\pm 3\%$  of its nominal diameter.

### 607. Breaking tests

Breaking tests for fibre ropes are to be carried out in accordance with the following requirements:

- (1) One specimen is to be taken from each coil of the fibre ropes. Where fibre ropes are continuously manufactured by the same machine with the yarns of the same type and divided into several coils, one specimen may be taken from one coil of the ropes selected by the Surveyor at random.
- (2) The length of the specimen is not to be less than 30 times the diameter of the hemp rope, but need not exceed one *metre*.
- (3) Specimens for polyethylene and polypropylene ropes are to be subjected to breaking tests in as wet condition immediately after having been immersed in warm water at  $35 \pm 2$  °C for more than 30 *minutes*. For other fibre ropes than the above ropes, specimens are to be subjected to breaking tests in as dry condition at room temperature.
- (4) The load at the time of breaking is not to be less than given in **Table 4.8.18**.

Table 4.8.18 Breaking test loads for fibre ropes (kN)

Diameter of rope (mm)	Hemp rope <sup>(1)</sup>	Synthetic fibre rope							Polyamide <sup>(1)</sup>
		Vinylon <sup>(1)</sup>		Polyethylene <sup>(2)</sup>		Polyester <sup>(1)</sup>	Polypropylene <sup>(2)</sup>		
		Grade 1	Grade 2	Grade 1	Grade 2		Grade 1	Grade 2	
10	7.06	9.32	15.7	9.71	12.7	15.6	10.8	12.7	18.1
12	9.90	13.4	21.8	13.9	17.7	22.0	15.7	17.7	27.5
14	13.1	17.9	28.4	18.6	23.5	29.2	20.6	23.5	36.6
16	16.9	22.9	36.3	23.8	29.4	37.5	26.5	29.4	46.9
18	21.0	28.6	45.1	29.7	37.3	46.7	32.4	37.3	58.3
20	25.6	34.8	54.9	36.1	44.1	56.8	39.2	44.1	70.9
22	30.5	41.6	65.7	43.1	54.9	67.8	47.1	54.9	84.6
24	35.9	48.8	77.5	50.7	63.7	79.6	54.9	63.7	100
26	41.6	56.7	89.2	58.8	73.5	92.4	63.7	73.5	116
28	47.8	65.1	103	67.5	83.4	106	73.5	83.4	132
30	54.3	74.0	117	76.8	97.1	121	83.4	97.1	151
32	61.2	83.5	131	86.5	108	136	94.1	108	170
35	72.3	99.0	155	102	127	161	111	127	201
40	95.4	127	198	131	164	206	142	164	258
45	119	157	247	163	203	260	177	203	321
50	144	191	300	198	250	312	214	250	390
55	173	228	358	237	294	373	255	294	466
60	203	269	421	279	348	438	300	348	547
65	235	312	487	324	402	508	348	402	635
70	271	358	559	371	461	583	399	461	729
75	307	407	635	422	525	663	453	525	829
80	346	459	716	476	593	747	511	593	935
85	387	514	801	533	667	837	572	667	1050
90	431	571	895	592	735	931	635	735	1170
95	477	632	981	655	814	1030	702	814	1280
100	525	694	1080	721	897	1140	772	897	1410
(Note)									
(1) Breaking load at room temperature in dried condition.									
(2) Breaking load at room temperature after having been immersed in warm water at 35 ± 2 °C for more than 30 minutes.									

### 608. Inspection of appearance and dimensions

Fibre ropes are to be inspected on the appearance and dimensions and they are to be in good order.

### 609. Marking

The fibre rope which has satisfactorily passed the tests and inspections is to be sealed with lead and affixed with the Society's brand indicating compliance with the rule requirements and the test number. Furthermore, diameter, mass, kind of ropes, coil length, manufacturing number and manufacturer are to be marked in proper way.

## Section 7 Hatch Tarpaulins

### 701. Application

1. Hatch tarpaulins to be equipped on ships in accordance with the provisions in **Ch 2** are to comply with the requirements in this Section or to be of equivalent quality.
2. The tests and inspections for hatch tarpaulins made of synthetic materials are to be to the discretion of the Society. **[See Guidance]**

### 702. Grades

The grades of tarpaulins are as follows:

Grade *A* tarpaulins (Mark, *TA*)

Grade *B* tarpaulins (Mark, *TB*)

### 703. Materials

Tarpaulins are to be made from cloths woven with flax yarn or cotton yarn of good quality.

### 704. Sewing

The overlapping, sewing threads and method of sewing for the purpose of joining the cloths used for tarpaulins are to be to the satisfaction of the Surveyor.

### 705. Mass

The mass of cloths used for tarpaulins before waterproof treatment is not to be less than 650 g/m<sup>2</sup> for Grade *A* tarpaulins and 490 g/m<sup>2</sup> for Grade *B* tarpaulins. Where, however, the waterproof mediums other than tar are used, the minimum mass may be reduced to 85 % of the above mass according to the characteristics of the mediums.

### 706. Tensile Tests

The strength of cloths used for tarpaulins before the waterproof treatment is not to be less than 80 kg for Grade *A* tarpaulins and 60 kg for Grade *B* tarpaulins in warp and woof, being tested with test pieces 30 mm wide and 200 mm long. Where, however, the waterproof mediums other than tar are used, the minimum strength may be reduced to 85 % of the above value according to the characteristics of the mediums.

### 707. Waterproof treatments

1. Waterproof mediums are to be made of suitable tar, grease or chemicals.
2. Tarpaulins are to pass the waterproofness tests which the Surveyor considers appropriate.
3. The waterproof medium applied to the tarpaulin is to prove free from adhesion, cracking or any other defect on its surface where it is folded at the temperature which is appropriate to this society.

### 708. Making

For the hatch tarpaulins which have been satisfactorily tested and inspected, the Society's brand, manufacturer, test number and grade identification of the hatch tarpaulins are to be marked on suitable places of the hatch tarpaulins.

## Section 8 Side Scuttles

### 801. Application

The side scuttles to be fitted up on ships according to the requirements in **Ch 4** (hereinafter referred to as side scuttle) are to comply with the requirements in this Section or to be of equivalent quality.

### 802. Types

Side scuttles are classified into following three types and divided into "fixed type" and "hinged type" according to the types of glass holders of the scuttles, and divided into "bolted type" and "welded type" according to the method of fastening the scuttles.

- (1) Type A scuttle (Mark *RPA*)
- (2) Type B scuttle (Mark *RPB*)
- (3) Type C scuttle (Mark *RPC*)

### 803. Construction and dimensions

The construction and dimensions of the main parts of the side scuttles are to be in accordance with the requirements in the followings and **Table 4.8.19** through **Table 4.8.21** according to their nominal diameters and classes. And the area of opening of side scuttles is not to exceed 0.16 m<sup>2</sup>.

(1) Maximum allowable pressure

The maximum allowable pressure for standard side scuttle is to be in accordance with the requirements as given **Table 4.8.19** through **Table 4.8.21**.

(2) Glazing

(A) An appropriate glazing material resistant to sea water and ultraviolet light is to be used.

(B) Mounting

When glazing, glass pane is to be centralized in the glass holder of hinged side scuttles or in the main frame of non-opening side scuttles so that there is the same clearance all round.

(3) Fasteners (closing devices and hinges)

(A) The minimum number of fasteners comprising closing devices and hinges with round hole for glassholders and deadlights of type A, B and C scuttles is to be in accordance with the requirements as given in **Table 4.8.19** through **Table 4.8.21**.

(B) The total number of the fasteners and their construction is to be such that the side scuttle meets the strength and weathertight test requirements according to **805**.

(C) Where the hole for the hinge of the glassholder and deadlight is oval, the hinge is not regarded as a fastener.

(4) Gaskets for glassholder and deadlight

(A) For ensuring watertightness between the glassholder and main frame and also between the deadlight and glassholder, gaskets type A or B according to ISO3902 are to be used.

(B) The gaskets are to be secured in the grooves by means of a suitable adhesive.

**Table 4.8.19 Type A side scuttle**

Main parts of side scuttle		Nominal dia. of scuttle (mm)				
		200	250	300	350	400
Max. allowable pressure (kPa)		328	302	328	241	297
Glass thickness (mm)		10	12	15	15	19
Obscured glass thickness (mm)*		15	19	-	-	-
Min. number of fasteners	Glass holder	2	3	3	3	3
	Deadlight	2	2	3	3	3

Table 4.8.20 Type B side scuttle

Main parts of side scuttle		Nominal dia. of scuttle (mm)					
		200	250	300	350	400	450
Max. allowable pressure (kPa)		210	134	146	154	118	146
Glass thickness (mm)		8	8	10	12	12	15
Obscured glass thickness (mm)*		12	12	15	19	19	-
Min. number of fasteners	Glass holder	2	3	3	3	3	4
	Deadlight	2	2	3	3	3	3

Table 4.8.21 Type C side scuttle

Main parts of side scuttle		Nominal dia. of scuttle (mm)					
		200	250	300	350	400	450
Max. allowable pressure (kPa)		118	75	93	68	82	65
Glass thickness (mm)		6	6	8	8	10	10
Obscured glass thickness (mm)*		10	10	12	12	15	15
Min. number of fasteners	Glass holder	2	2	3	3	3	3

\* Thickness of obscured glass panes when the obscured surface is facing inwards

## 804. Materials

### 1. Main components of the side scuttle

The materials used for the main components of side scuttles (main frame, glassholder, glass retaining ring and deadlight) are to be in accordance with the requirements as given in **Table 4.8.22**. These materials are to have the following properties.

- (1) Resistant corrosion
- (2) Mechanical properties as given in **Table 4.8.23**.

One tensile test specimen is to be taken from each cast. Where the number of casting from one cast exceed 50, an additional specimen is to be taken from each 50 castings of fraction thereof.

Table 4.8.22 Material classes

Type	Method of fastening	Material		
		Main frame	Glassholder and/or glass retaining ring	Deadlight
A	Bolted	Copper alloy <sup>(1)</sup>		Iron or steel <sup>(2)</sup>
	Welded	Mild steel	Copper alloy	Iron or steel <sup>(2)</sup>
		Mild steel		
B	Bolted	Copper alloy <sup>(1)</sup>		Iron or steel <sup>(2)</sup>
		Aluminium alloy <sup>(3)</sup>		
	Welded	Mild steel	Copper alloy	Iron or steel <sup>(2)</sup>
		Mild steel		
		Aluminium alloy		
		Aluminium alloy <sup>(4)</sup>	Aluminium alloy <sup>(3)</sup>	
C	Bolted	Copper alloy <sup>(1)</sup>		-
		Aluminium alloy <sup>(3)</sup>		
		Mild steel	Copper alloy	
		Mild steel		
		Aluminium alloy		
	Welded	Aluminium alloy <sup>(4)</sup>	Aluminium alloy <sup>(3)</sup>	

(Note)

<sup>(1)</sup> The use of brass(cast or wrought) or gun metal is optional.

<sup>(2)</sup> The use of iron(spheroidal graphite cast iron) or steel(mild steel or cast steel) is optional.

<sup>(3)</sup> The use of cast or wrought alloy is optional.

<sup>(4)</sup> The use of plate or extruded material is optional.

Table 4.8.23 Tensile strength and elongation for main components

Type	Minimum tensile strength (N/mm <sup>2</sup> )	Minimum elongation (%)
A	300	15
B	180	10
C	140	3

## 2. Closing devices

The materials used for bolts, pins and nuts of closing devices and hinge pins for glassholder are to have the following properties. For aluminum alloy side scuttle, the swingbolts of closing device and the hinge pins of glassholder are to be made of non-corrodible steel, stainless steel or such alloy which are not likely to cause corrosion of side scuttle bolts or pins.

- (1) Resistant corrosion
- (2) Mechanical properties as given in **Table 4.8.24**.

One tensile test specimen is to be taken from each cast. Where the number of casting from one cast exceed 50, an additional specimen is to be taken from each 50 castings of fraction thereof.

## 3. Glass panes

Toughened safety glass panes according to ISO21005 or glass panes of equivalent quality are to be used. For fire resistant glass panes, glass panes according to ISO5797 or glass panes of equivalent quality are to be used.

4. Where steel or iron is used, the side scuttles are to be galvanized.

Table 4.8.24 Tensile strength and elongation for the closing devices

Type	Swing bolt and pin, hinge pin		Nut	
	Minimum tensile strength (N/mm <sup>2</sup> )	Minimum elongation (%)	Minimum tensile strength (N/mm <sup>2</sup> )	Minimum elongation (%)
A	350	20	250	14
B	350	15	250	14
C	250	14	180	8

## 805. Testing

### 1. Watertightness test

The side scuttles are to be tested by being subjected to the hydraulic pressure given in **Table 4.8.25**. An equivalent hydraulic test is to be carried out by means of batch tests (approximately 10% of the delivery patch, with a minimum of two side scuttle) with glass pane and open deadlight, and without glass pane and closed deadlight.

### 2. Mechanical strength test

- (1) A prototype side scuttle without glass pane and with closed deadlight is to be subjected to a mechanical strength test by a punch method according to the test pressures given in **Table 4.8.26**. For this test, ISO614 is to be used as a guide.
- (2) The punch is to be placed on that side of the deadlight which could be subjected to direct contact with the sea. Where the construction of the deadlight makes it necessary, a plate of 100 mm diameter and 10 mm thickness may be placed between the punch and the deadlight.
- (3) When subjected to the pressure given in **Table 4.8.26**, the permanent deformation of the deadlight is not to exceed 1% of the normal size of the side scuttle.

### 3. Fire-resistant test

Side scuttles for fire-resistant constructions are to be subjected to prototype testing as given in ISO5797.

Table 4.8.25 Test pressure for watertightness

Type	Test pressure (kPa)	
	With glass pane, deadlight open	Without glass pane, deadlight closed
A	150	100
B	75	50
C	35	-

Table 4.8.26 Test pressure of mechanical test

Type	Test pressure (kPa)
A	240
B	120

### 806. Dispensation with tests

The tensile test specified in 804. and fire-resistance test specified in 805. 3. for side scuttles may be dispensed with, where these scuttles have appropriate certificates accepted by the Society.

### 807. Marking

For the side scuttles which have been satisfactorily tested and inspected, the Society's brand, test number and grade identification of the side scuttles are to be stamped on suitable places of the side scuttles.

## Section 9 Rectangular Windows

### 901. Application

The rectangular windows to be fitted up on ships according to the requirements in Ch 4 are to comply with the requirements in this chapter or to be of equivalent quality.

### 902. Types

Rectangular windows are classified into the following two types, divided into "fixed type" and "hinged type" according to the types of glassholders of the windows and divided into "bolted type" and "welded type" according to the method of fastening the windows.

- (1) Type *E* window(Mark *RPE*) (See Table 4.8.27)
- (2) Type *F* window(Mark *RPF*) (See Table 4.8.28)

### 903. Construction and dimensions

The construction and dimensions of the main parts of the rectangular windows are to be in accordance with the requirements in the following Sub-paragraphs and are determined in Table 4.8.27 and Table 4.8.28 in accordance with their nominal diameters and classes.

#### (1) Maximum allowable pressure

The maximum allowable pressure for rectangular window is to be in accordance with the requirements as given in Table 4.8.27 and Table 4.8.28. Where one or both dimensions(width and height) of a window are different from above, maximum allowable pressure(*p*) is to be determined using the following formula.

$$p = \frac{40000t^2}{\beta b^2} \quad (\text{kPa})$$

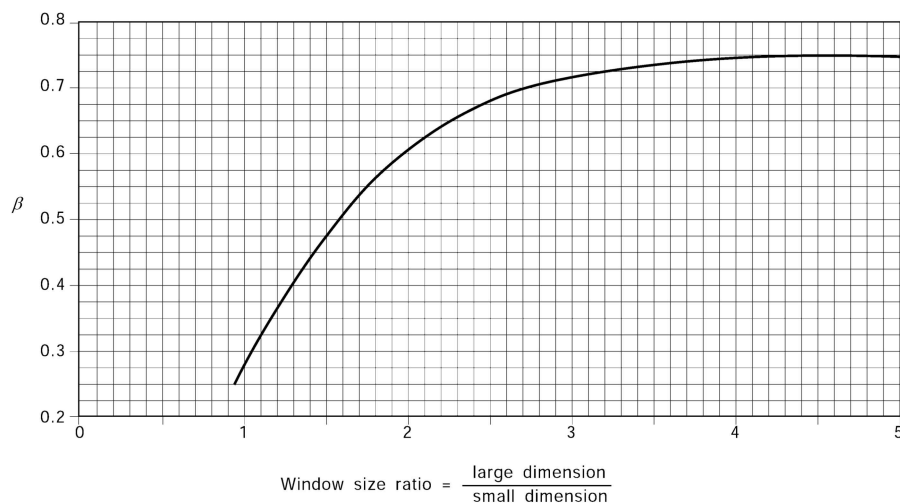
- $t$  : glass thickness (mm)
- $\beta$  : factor obtained from the graph of **Fig 4.8.8**
- $b$  : minor dimension of the window (mm)

**Table 4.8.27 Type E rectangular window**

Items	Nominal size, width (mm) × height (mm)							
	300×425	355×500	400×560	450×630	500×710	560×800	900×630	1000×710
Maximum allowable pressure (kPa)	99	71	80	63	80	64	81	64
Glass thickness (mm)	10	10	12	12	15	15	19	19
Obscured glass thickness (mm)	15	15	19	19	-	-	-	-
Minimum number of fasteners	4	4	4	4	6	6	6	8

**Table 4.8.28 Type F rectangular window**

Items	Nominal size, width (mm) × height (mm)									
	300×425	355×500	400×560	450×630	500×710	560×800	900×630	1000×710	1100×800	
Maximum allowable pressure (kPa)	63	45	36	28	36	28	32	25	31	
Glass thickness (mm)	8	8	8	8	10	10	12	12	15	
Obscured glass thickness (mm)	12	12	12	12	15	15	19	19	-	
Minimum number of fasteners	4	4	4	4	6	6	6	8	8	



**Fig 4.8.8 Curve for determination of  $\beta$  based on window size ratio**

- (2) Glazing  
 (A) Appropriate glazing material resistant to sea water and ultraviolet light is to be used.  
 (B) Mounting  
 When glazing, glass pane is to be centralized in the glassholder of hinged type rectangular windows or in the main frame of fixed type rectangular windows so that there is the same clearance all round.
- (3) Fasteners (closing device and hinge)  
 (A) The fasteners of glassholders and deadlights of type *E* and *F* windows are to be made up of the closing devices and hinges with round hole, and the number should be not less than that in the **Table 4.8.27** and **Table 4.8.28**.  
 (B) The total number of the fasteners and their construction is to be such that the rectangular window meets the strength and watertightness requirements in **905**.  
 (C) Where the hole for the hinge of the glassholder and deadlight is oval, the hinge is not regarded as a fastener.
- (4) Gaskets for glassholder and glass retaining frame  
 (A) For ensuring watertightness between the glassholder and main frame, gaskets type A, B and C according to ISO3902 are to be used.  
 (B) The gaskets are to be secured in the grooves by means of a suitable adhesive.
- (5) Fixing device  
 All sideways opening rectangular windows are to be provided with a fitted fixing device like hook.

## 904. Materials

### 1. Main frame, glassholder and glass retaining frame

The materials used for the main components of the rectangular windows (such as main frame, glassholder and glass retaining frame) are to be in accordance with the requirements as given in **Table 4.8.29** and these materials are to have the following properties.

**Table 4.8.29 Material**

Type of rectangular window	Method of fastening the rectangular window	Material		
		Main frame	Glassholder	Glass retaining ring
Hinged	Bolted	Brass <sup>(1)</sup>		
		Aluminium alloy <sup>(1)</sup>		
	Welded	Mild steel	Brass <sup>(1)</sup>	
		Mild steel		Brass <sup>(1)</sup>
		Mild steel		
		Mild steel	Aluminium alloy <sup>(1)</sup>	
Aluminium alloy (only wrought or extruded)		Aluminium alloy <sup>(1)</sup>		
Fixed	Bolted	Brass <sup>(1)</sup>	-	Brass <sup>(1)</sup>
		Aluminium alloy <sup>(1)</sup>	-	Aluminium alloy <sup>(1)</sup>
	Welded	Mild steel	-	Brass <sup>(1)</sup>
		Mild steel	-	Mild steel
		Mild steel	-	Aluminium alloy <sup>(1)</sup>
		Aluminium alloy (only wrought or extruded)	-	Aluminium alloy <sup>(1)</sup>

(Note)

<sup>(1)</sup> The use of cast or wrought alloy is optional.

- (1) resistant to corrosion
- (2) minimum mechanical properties as given in **Table 4.8.30**(One tensile test specimen is to be taken from each cast. Where the number of castings from one cast exceeds 50, an additional specimen is to be taken from each 50 castings of fraction thereof).

**Table 4.8.30 Tensile strength and elongation for the main components**

Type of rectangular window	Tensile strength (N/mm <sup>2</sup> ) min.	Elongation (%) min.
Type <i>E</i>	180	10
Type <i>F</i>	140	3

## 2. Closing device and hinge pin

The materials used for bolts, pins and nuts of closing devices and hinge pins for glassholder are to have the following properties.

For aluminum alloy rectangular windows, the bolts (screw-in bolt or swingbolt) of closing device and the hinge pin of the glassholder are to be made of non-corrodible steel, stainless steel or such alloy which are not likely to cause corrosion of rectangular windows, bolts and pins.

- (1) resistant to corrosion
- (2) no effect on the corrosion resistance of other parts
- (3) minimum mechanical properties as given in **Table 4.8.31**(One tensile test specimen is to be taken from each cast. Where the number of casting from one cast exceeds 50, an additional specimen is to be taken from each 50 castings of fraction thereof. For aluminum extruded shapes of aluminum alloy, the extruded shapes of the same dimensions, made from same cast and heat treated simultaneously, are treated as one lot and one tensile test specimen is to be taken from every lot. Where the number of extruded shapes from every lot exceeds 50, an additional specimen is to be taken from each 50 lots of fraction thereof.)

**Table 4.8.31 Tensile strength and elongation for the closing device**

Type of rectangular window	Swingbolt and pin, hinge pin		Nut	
	Minimum tensile strength (N/mm <sup>2</sup> )	Minimum elongation (%)	Minimum tensile strength (N/mm <sup>2</sup> )	Minimum elongation (%)
Type <i>E</i>	350	15	250	14
Type <i>F</i>	250	14	180	8

## 3. Glass panes

Toughened safety glass panes according to ISO21005 of glass panes of equivalent quality are to be used. For fire resistant glass panes, glass panes according to ISO5797 or glass panes of equivalent quality are to be used. For heated glass panes, glass panes according to ISO3434 or glass panes of equivalent quality are to be used.

4. Where steel or iron is used, the rectangular windows are to be galvanized.

## 905. Testing

### 1. Watertightness test

An equivalent hydraulic test is to be carried out by means of batch tests(approximately 10% of the delivery batch, with a minimum one window) at a test pressure 25 kPa.

### 2. Mechanical strength test

A prototype rectangular window is to be subject to a mechanical strength test by a suitable test method, applying a load equivalent to the pressures in **Table 4.8.32**.

Table 4.8.32 Mechanical strength test pressure

Types	Test pressure (kPa)
E	75
F	35

### 3. Fire-resistant test

Rectangular windows for fire-resistant constructions are to be subjected to prototype testing as given in ISO5797.

### 4. Test for heated windows

Heated rectangular windows are to be subjected to the electrical testing as given in ISO3434 clause 6.

### 906. Dispensation with tests [See Guidance]

The tensile test specified in 904. and fire-resistant test specified in 905. 3 may be dispensed with, where these windows have appropriate certificates accepted by the Society.

### 907. Marking

For the rectangular windows which have been satisfactorily tested and inspected, the Society's brand, test number and grade identification of the rectangular windows are to be stamped on suitable. ↓

# CHAPTER 9 STRENGTH AND SECURING OF SMALL HATCHES, FITTINGS AND EQUIPMENT ON THE FORE DECK

## Section 1 Application and Implementation

### 101. Application

1. For ships that are contracted for construction on or after 1 January 2004 on the exposed deck over the forward  $0.25L$ , applicable to:

All ship types of sea going service of length 80 m or more, where the height of the exposed deck in way of the hatch is less than  $0.1L$  or 22 m above the summer load waterline, whichever is the lesser.

2. For ships that are contracted for construction prior to 1 January 2004 only for hatches on the exposed deck giving access to spaces forward of the collision bulkhead, and to spaces which extend over this line aft-wards, applicable to:

Bulk carriers, general dry cargo ships (excluding container vessels, vehicle carriers, Ro-Ro ships and woodchip carriers), and combination carriers (e.g. OBO ships, Ore/Oil Carriers, etc.), of length 100 m or more.

### 102. Implementation

The detail requirements for implementation of this chapter, refer to **Pt 1, Ch 2, 1701.** of the Rules.

## Section 2 Strength and Securing of Small Hatches on the Exposed Fore Deck

### 201. General

1. The strength of, and securing devices for, small hatches fitted on the exposed fore deck are to comply with the requirements of this Section.
2. Small hatches in the context of this Section are hatches designed for access to spaces below the deck and are capable to be closed weather-tight or watertight, as applicable. Their opening is normally 2.5 square meters or less.
3. Hatches designed for use of emergency escape are to comply with the requirements of this Section, excepting **203. 1** (1) and (2) **204. 3** and **205.** **[See Guidance]**

### 202. Strength

1. For small rectangular steel hatch covers, the plate thickness, stiffener arrangement and scantlings are to be in accordance with **Table 4.9.1**, and **Fig 4.9.1**. Stiffeners, where fitted, are to be aligned with the metal-to-metal contact points, required in **204. 1** (see **Fig 4.9.1.**) Primary stiffeners are to be continuous. All stiffeners are to be welded to the inner edge stiffener, see **Fig 4.9.2.**
2. The upper edge of the hatchway coamings is to be suitably reinforced by a horizontal section, normally not more than 170 to 190 mm from the upper edge of the coamings.
3. For small hatch covers of circular or similar shape, the cover plate thickness and reinforcement is to be in accordance with the requirement specified by the Society. **[See Guidance]**
4. For small hatch covers constructed of materials other than steel, the required scantlings are to provide equivalent strength.

### 203. Primary securing devices

1. Small hatches located on exposed fore deck subject to the application of this section are to be fitted with primary securing devices such that their hatch covers can be secured in place and weather-tight by means of a mechanism employing any one of the following methods:
  - (1) Butterfly nuts tightening onto forks (clamps),
  - (2) Quick acting cleats, or
  - (3) Central locking device.
2. Dogs (twist tightening handles) with wedges are not acceptable.

### 204. Requirements for primary securing

1. The hatch cover is to be fitted with a gasket of elastic material. This is to be designed to allow a metal to metal contact at a designed compression and to prevent over compression of the gasket by green sea forces that may cause the securing devices to be loosened or dislodged. The metal-to-metal contacts are to be arranged close to each securing device in accordance with **Fig 4.9.1** and of sufficient capacity to withstand the bearing force.
2. The primary securing method is to be designed and manufactured such that the designed compression pressure is achieved by one person without the need of any tools.
3. For a primary securing method using butterfly nuts, the forks (clamps) are to be of robust design. They are to be designed to minimize the risk of butterfly nuts being dislodged while in use; by means of curving the forks upward, a raised surface on the free end, or a similar method. The plate thickness of unstiffened steel forks is not to be less than 16 mm. An example arrangement is shown in **Fig 4.9.2**.
4. For small hatch covers located on the exposed deck forward of the fore-most cargo hatch, the hinges are to be fitted such that the predominant direction of green sea will cause the cover to close, which means that the hinges are normally to be located on the fore edge.
5. On small hatches located between the main hatches, for example between Nos. 1 and 2, the hinges are to be placed on the fore edge or outboard edge, whichever is practicable for protection from green water in beam sea and bow quartering conditions.

### 205. Secondary securing device

Small hatches on the fore deck are to be fitted with an independent secondary securing device e.g. by means of a sliding bolt, a hasp or a backing bar of slack fit, which is capable of keeping the hatch cover in place, even in the event that the primary securing device became loosened or dislodged. It is to be fitted on the side opposite to the hatch cover hinges.

**Table 4.9.1 Scantlings for small steel hatch covers on the fore deck**

Nominal size (mm x mm)	Cover plate thickness (mm)	Primary stiffeners	Secondary stiffeners
		Flat Bar (mm x mm) ; number	
630×630	8	-	-
630×830	8	100×8 ; 1	-
830×630	8	100×8 ; 1	-
830×830	8	100×10 ; 1	-
1030×1030	8	120×12 ; 1	80×8 ; 2
1330×1330	8	150×12 ; 2	100×10 ; 2

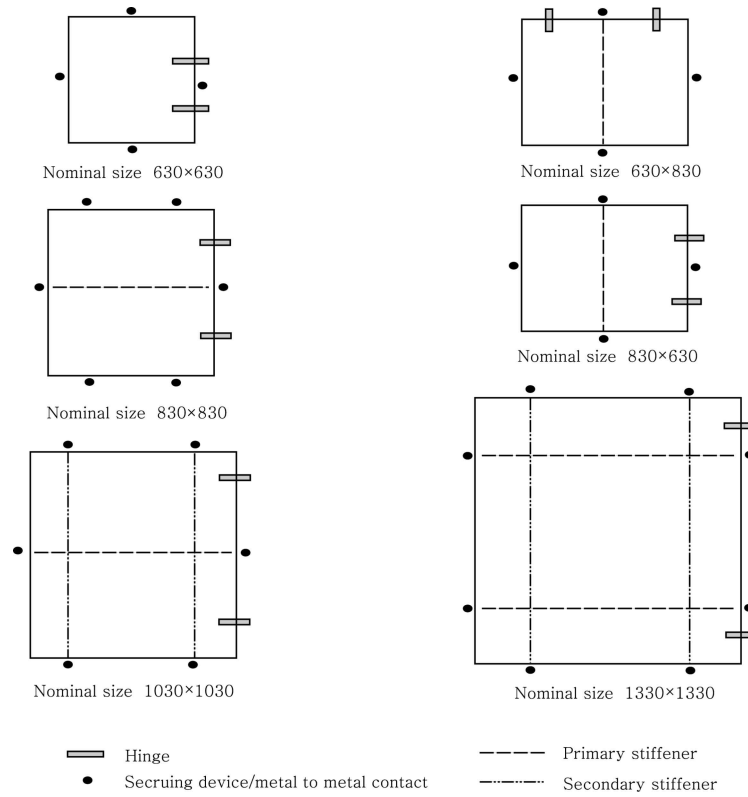
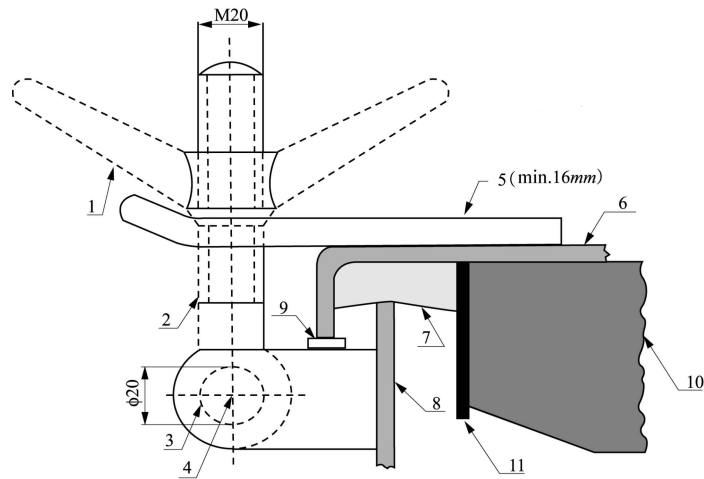


Fig 4.9.1 Arrangement of stiffeners



(Note: Dimensions in mm)

- 1: butterfly nut
- 2: bolt
- 3: pin
- 4: center of pin
- 5: fork (clamp) plate
- 6: hatch cover
- 7: gasket
- 8: hatch coaming
- 9: bearing pad welded on the bracket of a toggle bolt for metal to metal contact
- 10: stiffener
- 11: inner edge stiffener

Fig 4.9.2 Example of a primary securing method

## Section 3 Strength Requirements for Fore Deck Fittings and Equipment

### 301. General

1. This section provides strength requirements to resist green sea forces for the following items :  
air pipes, ventilator pipes and their closing devices, the securing of windlasses.
2. For windlasses, these requirements are additional to those appertaining to the anchor and chain performance criteria of **Pt 5, Ch 8** of the Rules.
3. Where mooring winches are integral with the anchor windlass, they are to be considered as part of the windlass.

### 302. Applied loading

1. Air pipes, ventilator pipes and their closing devices

(1) The pressures  $p$ , in  $\text{kN/m}^2$  acting on air pipes, ventilator pipes and their closing devices may be calculated from:

$$p = 0.5\rho V^2 C_d C_s C_p \quad (\text{kN/m}^2)$$

where :

$\rho$  = density of sea water ( $1.025 \text{ t/m}^3$ )

$V$  = velocity of water over the fore deck

=  $13.5 \text{ m/sec}$  for  $d \leq d_l$

=  $13.5 \sqrt{2(1 - \frac{d}{d_l})}$  (m/sec) for  $0.5d_l < d < d_l$

$d$  = distance from summer load waterline to exposed deck

$d_l$  =  $0.1L$  or  $22\text{m}$  whichever is the lesser

$C_d$  = shape coefficient

=  $0.5$  for pipes,

=  $1.3$  for air pipe or ventilator heads in general,

=  $0.8$  for an air pipe or ventilator head of cylindrical form with its axis in the vertical direction.

$C_s$  = slamming coefficient (3.2)

$C_p$  = protection coefficient:

=  $0.7$  for pipes and ventilator heads located immediately behind a breakwater or fore-castle,

=  $1.0$  elsewhere and immediately behind a bulwark.

(2) Forces acting in the horizontal direction on the pipe and its closing device may be calculated from (1) using the largest projected area of each component.

### 2. Windlasses

(1) The following pressures and associated areas are to be applied (see **Fig 4.9.3**):

- $200 \text{ kN/m}^2$  normal to the shaft axis and away from the forward perpendicular, over the projected area in this direction,
- $150 \text{ kN/m}^2$  parallel to the shaft axis and acting both inboard and outboard separately, over the multiple of  $f$  times the projected area in this direction,

where  $f$  is defined as:

$f = 1 + B/H$ , but not greater than  $2.5$

where:

$B$  = width of windlass measured parallel to the shaft axis,

$H$  = overall height of windlass.

- (2) Forces in the bolts, chocks and stoppers securing the windlass to the deck are to be calculated. The windlass is supported by  $N$  bolt groups, each containing one or more bolts, see **Fig 4.9.4**.
- (3) The axial force  $R_i$  in bolt group (or bolt)  $i$ , positive in tension, may be calculated from:

$$R_{xi} = \frac{P_x h x_i A_i}{I_x}, \quad R_{yi} = \frac{P_y h y_i A_i}{I_y}, \quad R_i = R_{xi} + R_{yi} - R_{si}$$

where:

$P_x$  = force (kN) acting normal to the shaft axis

$P_y$  = force (kN) acting parallel to the shaft axis, either inboard or outboard whichever gives the greater force in bolt group  $i$

$h$  = shaft height above the windlass mounting (cm)

$x_i, y_i$  =  $x$  and  $y$  coordinates of bolt group  $i$  from the centroid of all  $N$  bolt groups, positive in the direction opposite to that of the applied force (cm)

$A_i$  = cross sectional area of all bolts in group  $i$  (cm<sup>2</sup>)

$I_x = \sum A_i x_i^2$  for  $N$  bolt groups

$I_y = \sum A_i y_i^2$  for  $N$  bolt groups

$R_{si}$  = static reaction at bolt group  $i$ , due to weight of windlass.

- (4) Shear forces  $F_{xi}, F_{yi}$  applied to the bolt group  $i$ , and the resultant combined force  $F_i$  may be calculated from:

$$F_{xi} = \frac{P_x - \alpha g M}{N}, \quad F_{yi} = \frac{P_y - \alpha g M}{N}, \quad F_i = \sqrt{F_{xi}^2 + F_{yi}^2}$$

$\alpha$  = coefficient of friction (0.5)

$M$  = mass of windlass (tonnes)

$g$  = gravity acceleration (9.81 m/s<sup>2</sup>)

$N$  = number of bolt groups.

- (5) Axial tensile and compressive forces in (3) and lateral forces in (4) are also to be considered in the design of the supporting structure.

### 303. Strength Requirements

#### 1. Air pipes, ventilator pipes and their closing devices

- (1) These requirements are additional to **Pt 5, Ch 6, Sec 2** of the Rules.
- (2) Bending moments and stresses in air and ventilator pipes are to be calculated at critical positions: at penetration pieces, at weld or flange connections, at toes of supporting brackets. Bending stresses in the net section are not to exceed  $0.8\sigma_y$ , where  $\sigma_y$  is the specified minimum yield stress or 0.2% proof stress of the steel at room temperature. Irrespective of corrosion protection, a corrosion addition to the net section of 2.0 mm is then to be applied.
- (3) For standard air pipes of 760 mm height closed by heads of not more than the tabulated projected area, pipe thicknesses and bracket heights are specified in **Table 4.9.2** Where brackets are required, three or more radial brackets are to be fitted. Brackets are to be of gross thickness 8 mm or more, of minimum length 100 mm, and height according to **Table 4.9.2** but need not extend over the joint flange for the head. Bracket toes at the deck are to be suitably supported.
- (4) For other configurations, loads according to **302.** are to be applied, and means of support de-

terminated in order to comply with the requirements of (2). Brackets, where fitted, are to be of suitable thickness and length according to their height. Pipe thickness is not to be taken less than as indicated in **Pt 5, Ch 6, 102** of the Rules.

- (5) For standard ventilators of 900 mm height closed by heads of not more than the tabulated projected area, pipe thicknesses and bracket heights are specified in **Table 4.9.3** Brackets, where required are to be as specified in (3).
- (6) For ventilators of height greater than 900 mm, brackets or alternative means of support are to be fitted according to the requirements of each Society. Pipe thickness is not to be taken less than as indicated in **Pt 5, Ch 6, 102** of the Rules.
- (7) All component parts and connections of the air pipe or ventilator are to be capable of withstanding the loads defined in **302. 1**.
- (8) Rotating type mushroom ventilator heads are unsuitable for application on the exposed deck over the forward  $0.25L$

## 2. Windlass mounts

- (1) Tensile axial stresses in the individual bolts in each bolt group  $i$  are to be calculated. The horizontal forces  $F_{x_i}$  and  $F_{y_i}$  are normally to be reacted by shear chocks. Where "fitted" bolts are designed to support these shear forces in one or both directions, the von Mises equivalent stresses in the individual bolts are to be calculated, and compared to the stress under proof load. Where pourable resins are incorporated in the holding down arrangements, due account is to be taken in the calculations. The safety factor against bolt proof strength is to be not less than 2.0.
- (2) The strength of above deck framing and hull structure supporting the windlass and its securing bolt loads as defined in **302. 2** is to be according to the requirements of the Society.

## 3. Chain stoppers

- (1) A chain stopper is generally to be fitted between the windlass and the hawse pipe in order to relieve the windlass of the pull of the chain cable when the ship is at anchor. A chain stopper is to be capable of withstanding a load equal to 80% of the breaking load of the chain cable without undergoing permanent deformation.
- (2) National Standards, internationally recognized Codes or Standards considered as equivalent for those may be applied instead of requirements of this Section. ↓

Table 4.9.2 760 mm air pipe thickness and bracket standards

Nominal pipe diameter (mm)	Minimum fitted gross thickness (mm)	Maximum projected area of head (cm <sup>2</sup> )	Height <sup>(1)</sup> of bracket (mm)
40A <sup>(3)</sup>	6.0	-	520
50A <sup>(3)</sup>	6.0	-	520
65A	6.0	-	480
80A	6.3	-	460
100A	7.0	-	380
125A	7.8	-	300
150A	8.5	-	300
175A	8.5	-	300
200A	8.5 <sup>(2)</sup>	1900	300 <sup>(3)</sup>
250A	8.5 <sup>(2)</sup>	2500	300 <sup>(2)</sup>
300A	8.5 <sup>(2)</sup>	3200	300 <sup>(2)</sup>
350A	8.5 <sup>(2)</sup>	3800	300 <sup>(2)</sup>
400A	8.5 <sup>(2)</sup>	4500	300 <sup>(2)</sup>

<sup>(1)</sup> Brackets (see **303. 1. (3)**) need not extend over the joint flange for the head.

<sup>(2)</sup> Brackets are required where the as fitted (gross) thickness is less than 10.5 mm, or where the tabulated projected head area is exceeded.

<sup>(3)</sup> Not permitted for new ships. Reference **Pt 5, Ch 6** of the Rules.

Note: For other air pipe heights, the relevant requirements of **303. 1.** are to be applied.

Table 4.9.3 900 mm Ventilator pipe thickness and bracket standards

Nominal pipe diameter (mm)	Minimum fitted gross thickness (mm)	Maximum projected area of head (cm <sup>2</sup> )	Height of bracket (mm)
80A	6.3	-	460
100A	7.0	-	380
150A	8.5	-	300
200A	8.5	550	-
250A	8.5	880	-
300A	8.5	1200	-
350A	8.5	2000	-
400A	8.5	2700	-
450A	8.5	3300	-
500A	8.5	4000	-

Note: For other ventilator heights, the relevant requirements of **303. 1** are to be applied.

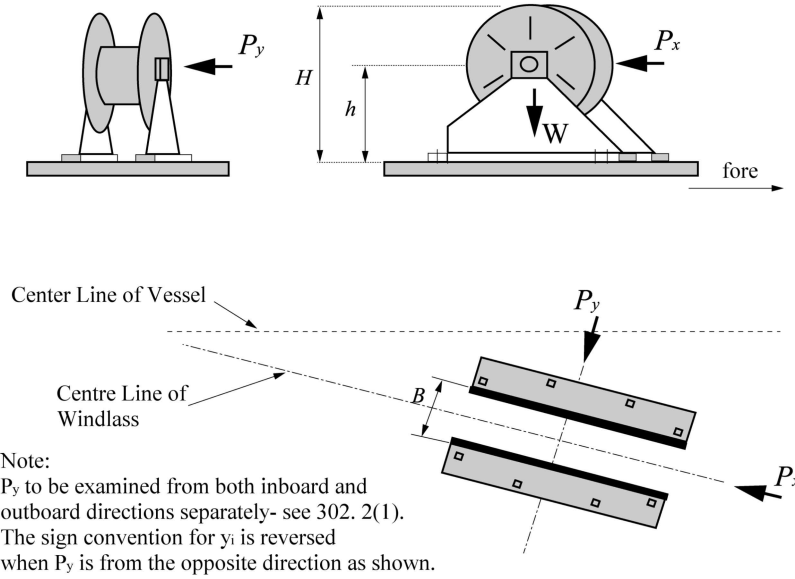


Fig 4.9.3 Direction of force and weight

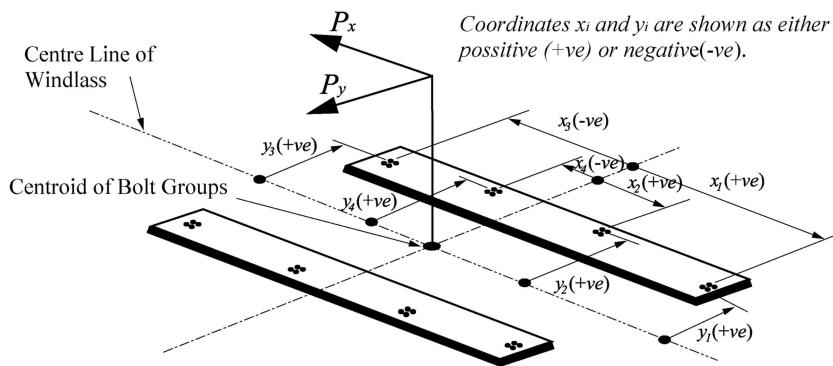


Fig 4.9.4 Sign convention

# CHAPTER 10 SHIPBOARD EQUIPMENT, FITTINGS AND SUPPORTING HULL STRUCTURES ASSOCIATED WITH TOWING AND MOORING

## Section 1 Definitions and Scope of Application

### 101. Application (2018)

1. Conventional ships (new displacement-type vessels ships of 500 GT and above, excluding high speed craft, special purpose vessels ships, and offshore units of all types.) are to be provided with arrangements, equipment and fittings of sufficient safe working load to enable the safe conduct of all towing and mooring operations associated with the normal operations of the ship.
2. This Chapter is to apply to design and construction of shipboard fittings and supporting structures used for the normal towing and mooring operations. Normal towing means towing operations necessary for manoeuvring in ports and sheltered waters associated with the normal operations of the ship.
3. For ships, not subject to SOLAS Regulation II-1/3-4 Paragraph 1, but intended to be fitted with equipment for towing by another ship or a tug, e.g. such as to assist the ship in case of emergency as given in SOLAS Regulation II-1/3-4 Paragraph 2, the requirements designated as 'other towing' in this Unified Requirement are to be applied to design and construction of those shipboard fittings and supporting hull structures.
4. This Chapter is not applicable to design and construction of shipboard fittings and supporting hull structures used for special towing services defined as:
  - (1) Escort towing: Towing service, in particular, for laden oil tankers or LNG carriers, required in specific estuaries. Its main purpose is to control the ship in case of failures of the propulsion or steering system. It should be referred to local escort requirements and guidance given by, e.g., the Oil Companies International Marine Forum (OCIMF).
  - (2) Canal transit towing: Towing service for ships transiting canals, e.g. the Panama Canal. It should be referred to local canal transit requirements.
  - (3) Emergency towing for tankers: Towing service to assist tankers in case of emergency. For the emergency towing arrangements, ships subject to SOLAS regulation II-1/3-4 Paragraph 1 are to comply with that regulation and resolution MSC.35(63) as may be amended.
5. IACS Recommendation No. 10 "Anchoring, Mooring and Towing Equipment" may be referred to for recommendations concerning mooring and towing.
6. The net minimum scantlings of the supporting hull structure are to comply with the requirements given in **201. 5** and **202. 5**. The net thicknesses,  $t_{net}$ , are the member thicknesses necessary to obtain the above required minimum net scantlings. The required gross thicknesses are obtained by adding the total corrosion additions,  $t_c$ , given in **204.**, to  $t_{net}$ . Shipboard fittings are to comply with the requirements given in **201. 4** and **202. 4**. For shipboard fittings not selected from an accepted industry standard the corrosion addition,  $t_c$ , and the wear allowance,  $t_w$ , given in **204.** and **205.**, respectively, are to be considered.
7. The mooring equipment of single point moorings which fitted on ships such as oil tanker the delivery of which is after 1 January 2009 are to be in accordance with the Guidance relating to the Rules specified by the Society. **[See Guidance]**

### 102. Definitions (2018)

1. Conventional ships means new displacement-type ships of 500 GT and above, excluding high speed craft, special purpose ships, and offshore units of all types. As per MSC.266(84), 'Special purpose ship' means a mechanically self-propelled ship which by reason of its function carries on board more than 12 special personnel.
2. Shipboard fittings mean those components limited to the following: Bollards and bits, fairleads, stand rollers, chocks used for normal mooring of the ship and the similar components used for normal or other towing of the ship. Other components such as capstans, winches, etc. are not covered

by this Unified Requirement. Any weld or bolt or equivalent device connecting the shipboard fitting to the supporting structure is part of the shipboard fitting and if selected from an industry standard subject to that standard.

3. Supporting hull structures means that part of the ship structure on/in which the shipboard fitting is placed and which is directly submitted to the forces exerted on the shipboard fitting. The supporting hull structure of capstans, winches, etc. used for the normal or other towing and mooring operations mentioned above is also subject to this chapter.
4. Industry standard means international standard(ISO etc.) or standards issued by national association(KS, DIN, JMSA etc.) which are recognized in the country where the ship is built.

## Section 2 Towing and Mooring

### 201. Towing (2018)

#### 1. Strength

The strength of shipboard fittings used for normal towing operations at bow, sides and stern and their supporting hull structures are to comply with the requirements of this chapter.

Where a ship is equipped with shipboard fittings intended to be used for other towing services, the strength of these fittings and their supporting hull structures are to comply with the requirements of this chapter.

#### 2. Arrangement

Shipboard fittings for towing are to be located on stiffeners, and/or girders, which are part of the deck construction so as to facilitate efficient distribution of the towing load. Other equivalent arrangements may be accepted (for chocks in bulwarks, etc.) provided the strength is confirmed adequate for the intended service.

#### 3. Load considerations

The minimum design load applied to supporting hull structures for shipboard fittings is to be:

- (1) For normal towing operations  
1.25 times the intended maximum towing load (e.g. static bollard pull) as indicated on the towing and mooring arrangements plan.
- (2) For other towing service  
the minimum breaking strength of the tow line according to **Ch 8, Table 4.8.1**.
- (3) For fittings intended to be used for, both, normal and other towing operations, the greater of the design loads according to (1) and (2).

Notes:

- 1) Side projected area including that of deck cargoes as given by the loading manual is to be taken into account for selection of towing lines and the loads applied to shipboard fittings and supporting hull structure.
- 2) The increase of the minimum breaking strength for synthetic ropes according to Recommendation No. 10 needs not to be taken into account for the loads applied to shipboard fittings and supporting hull structure.

When a safe towing load TOW greater than that determined according to **201. 6** is requested by the applicant, then the design load is to be increased in accordance with the appropriate TOW/design load relationship given by **201. 3** and **201. 6**.

The design load is to be applied to fittings in all directions that may occur by taking into account the arrangement shown on the towing and mooring arrangements plan. Where the towing line takes a turn at a fitting the total design load applied to the fitting is equal to the resultant of the design loads acting on the line, see **Fig 4.10.1**. However, in no case does the design load applied to the fitting need to be greater than twice the design load on the line.

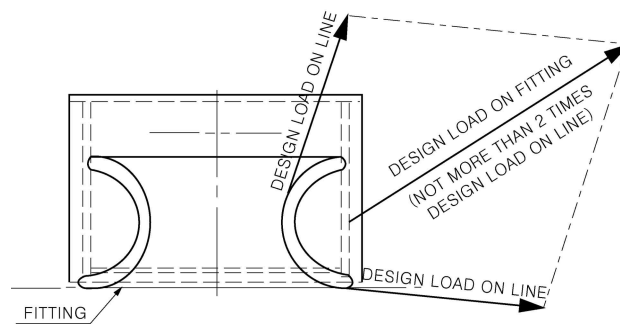


Fig 4.10.1 Application of design load

#### 4. Shipboard fittings

Shipboard fittings may be selected from an industry standard accepted by the Society and at least based on the following loads.

- (1) For normal towing operations the intended maximum towing load (e.g. static bollard pull) as indicated on the towing and mooring arrangements plan,
- (2) For other towing service the minimum breaking strength of the tow line according to **Ch 8, Table 4.8.1**. (see Notes in **201. 3**)
- (3) For fittings intended to be used for, both, normal and other towing operations, the greater of the loads according to (1) and (2).

Towing bitts (double bollards) may be chosen for the towing line attached with eye splice if the industry standard distinguishes between different methods to attach the line, i.e. figure-of-eight or eye splice attachment.

When the shipboard fitting is not selected from an accepted industry standard, the strength of the fitting and of its attachment to the ship is to be in accordance with **201. 3** and **201. 5**. Towing bitts (double bollards) are required to resist the loads caused by the towing line attached with eye splice. For strength assessment beam theory or finite element analysis using net scantlings is to be applied, as appropriate. Corrosion additions are to be as defined in **204**. A wear down allowance is to be included as defined in **205**. At the discretion of the Society, load tests may be accepted as alternative to strength assessment by calculations.

#### 5. Supporting hull structure

The design load applied to supporting hull structure is to be in accordance with **201. 3**.

- (1) The reinforced members beneath shipboard fittings are to be effectively arranged for any variation of direction (horizontally and vertically) of the towing forces acting the shipboard fittings, see **Fig 4.10.2** for a sample arrangement. Proper alignment of fitting and supporting hull structure is to be ensured.

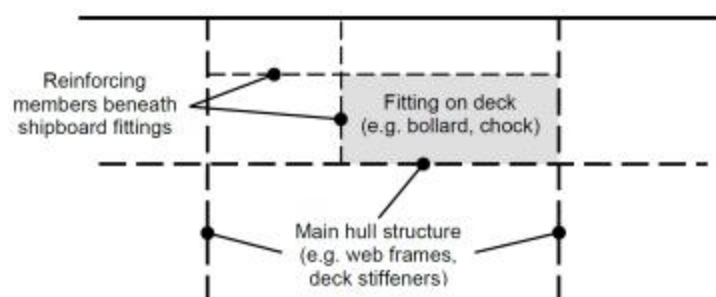


Fig 4.10.2 Sample arrangement of reinforcing members

- (2) The acting point of the towing force on shipboard fittings is to be taken at the attachment point of a towing line or at a change in its direction. For bollards and bitts the attachment point of the towing line is to be taken not less than  $\frac{4}{5}$  of the tube height above the base, see Fig 4.10.3.

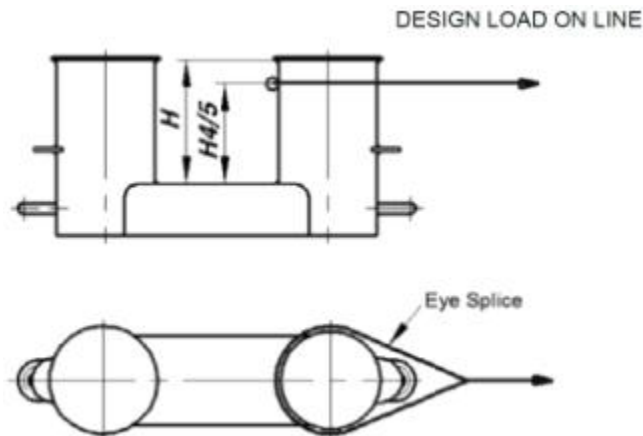


Fig 4.10.3 Acting point of the towing force

- (3) Allowable stresses under the design load conditions as specified in **201. 3** are as follows:

(A) For strength assessment with beam theory or grillage analysis:

Normal stress : 100 % of the specified minimum yield point of the material

Shearing stress : 60 % of the specified minimum yield point of the material

Normal stress is the sum of bending stress and axial stress with the corresponding shearing stress acting perpendicular to the normal stress. No stress concentration factors being taken into account.

(B) For strength assessment with finite element analysis:

Equivalent stress : 100 % of the specified minimum yield point of the material.

For strength calculations by means of finite elements, the geometry is to be idealized as realistically as possible. The ratio of element length to width is not to exceed 3. Girders are to be modelled using shell or plane stress elements. Symmetric girder flanges may be modelled by beam or truss elements. The element height of girder webs must not exceed one-third of the web height. In way of small openings in girder webs the web thickness is to be reduced to a mean thickness over the web height. Large openings are to be modelled. Stiffeners may be modelled by using shell, plane stress, or beam elements. Stresses are to be read from the centre of the individual element. For shell elements the stresses are to be evaluated at the mid plane of the element.

## 6. Safe Towing Load (TOW)

- (1) The safe towing load (TOW) is the load limit for towing purpose.
- (2) TOW used for normal towing operations is not to exceed 80% of the design load per **201. 3** (1).
- (3) TOW used for other towing operations is not to exceed 80% of the design load according to **201. 3** (2).
- (4) For fittings used for both normal and other towing operations, the greater of the safe towing loads according to (2) and (3) is to be used.
- (5) For fittings intended to be used for, both, towing and mooring, **202.** applies to mooring.
- (6) TOW, in t, of each shipboard fitting is to be marked (by weld bead or equivalent) on the deck fittings used for towing. For fittings intended to be used for, both, towing and mooring, SWL, in t, according to **202. 6** is to be marked in addition to TOW.

- (7) The above requirements on TOW apply for the use with no more than one line. If not otherwise chosen, for towing bitts (double bollards) TOW is the load limit for a towing line attached with eye-splice.
- (8) The towing and mooring arrangements plan mentioned in **203**, is to define the method of use of towing lines.

## 202. Mooring (2018)

### 1. Strength

The strength of shipboard fittings used for mooring operations and of their supporting hull structures as well as the strength of supporting hull structures of winches and capstans is to comply with the requirements of this Chapter.

### 2. Arrangements

Shipboard fittings, winches and capstans for mooring are to be located on stiffeners and/or girders, which are part of the deck construction so as to facilitate efficient distribution of the mooring load. Other equivalent arrangements may be accepted (for chocks in bulwarks, etc.) provided the strength is confirmed adequate for the service.

### 3. Load considerations

- (1) The minimum design load applied to supporting hull structures for shipboard fittings is to be 1.15 times the minimum breaking strength of the mooring line according to **Ch 8, Table 4.8.1**.
- (2) The minimum design load applied to supporting hull structures for winches is to be 1.25 times the intended maximum brake holding load, where the maximum brake holding load is to be assumed not less than 80% of the minimum breaking strength of the mooring line according to **Ch 8, Table 4.8.1**, see Notes. For supporting hull structures of capstans, 1.25 times the maximum hauling-in force is to be taken as the minimum design load.
- (3) When a safe working load SWL greater than that determined according to **202. 6** is requested by the applicant, then the design load is to be increased in accordance with the appropriate SWL/design load relationship given by **202. 3** and **202. 6**.
- (4) The design load is to be applied to fittings in all directions that may occur by taking into account the arrangement shown on the towing and mooring arrangements plan. Where the mooring line takes a turn at a fitting the total design load applied to the fitting is equal to the resultant of the design loads acting on the line, refer to the **Fig 4.10.1** in **201. 3**. However, in no case does the design load applied to the fitting need to be greater than twice the design load on the line.

Notes:

- 1) If not otherwise specified by Recommendation No. 10, side projected area including that of deck cargoes as given by the loading manual is to be taken into account for selection of mooring lines and the loads applied to shipboard fittings and supporting hull structure.
- 2) The increase of the minimum breaking strength for synthetic ropes according to Recommendation No. 10 needs not to be taken into account for the loads applied to shipboard fittings and supporting hull structure.

### 4. Shipboard fittings

- (1) Shipboard fittings may be selected from an industry standard accepted by the Society and at least based on the minimum breaking strength of the mooring line according to **Ch 8, Table 4.8.1**. (see Notes in **202. 3**)
- (2) Mooring bitts (double bollards) are to be chosen for the mooring line attached in figure-of-eight fashion if the industry standard distinguishes between different methods to attach the line, i.e. figure-of-eight or eye splice attachment.
- (3) When the shipboard fitting is not selected from an accepted industry standard, the strength of the fitting and of its attachment to the ship is to be in accordance with **202. 3** and **202. 5**. Mooring bitts (double bollards) are required to resist the loads caused by the mooring line attached in figure-of-eight fashion, see Note. For strength assessment beam theory or finite element analysis using net scantlings is to be applied, as appropriate. Corrosion additions are to be as defined in **204**. A wear down allowance is to be included as defined in **205**. At the discretion of the classification Society, load tests may be accepted as alternative to strength assessment by calculations.

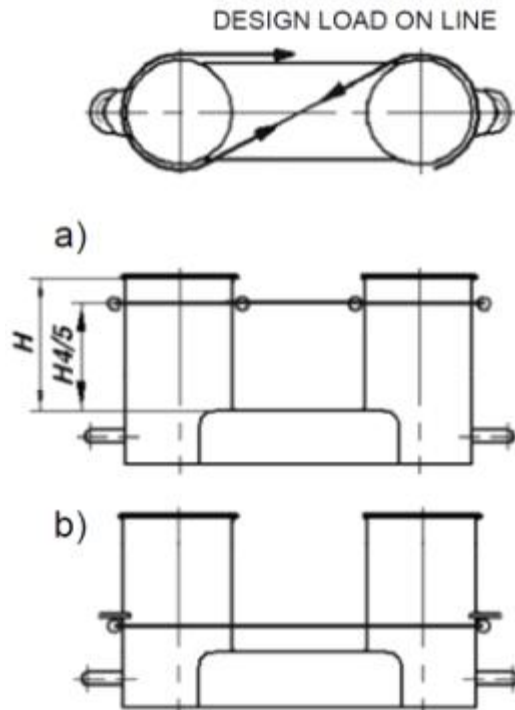
## Notes:

With the line attached to a mooring bitt in the usual way (figure-of-eight fashion), either of the two posts of the mooring bitt can be subjected to a force twice as large as that acting on the mooring line. Disregarding this effect, depending on the applied industry standard and fitting size, overload may occur.

### 5. Supporting hull structures

The design load applied to supporting hull structure is to be in accordance with **202. 3**.

- (1) The arrangement of reinforced members beneath shipboard fittings, winches and capstans is to consider any variation of direction (horizontally and vertically) of the mooring forces acting upon the shipboard fittings, see **Fig 4.10.2** in **201. 5** for a sample arrangement. Proper alignment of fitting and supporting hull structure is to be ensured.
- (2) The acting point of the mooring force on shipboard fittings is to be taken at the attachment point of a mooring line or at a change in its direction. For bollards and bitts the attachment point of the mooring line is to be taken not less than  $4/5$  of the tube height above the base, see a) in **Fig 4.10.4**. However, if fins are fitted to the bollard tubes to keep the mooring line as low as possible, the attachment point of the mooring line may be taken at the location of the fins, see b) in **Fig 4.10.4**.



**Fig 4.10.4** Acting point of the mooring force

- (3) Allowable stresses under the design load conditions as specified in **202. 3** are as follows:

(A) For strength assessment with beam theory or grillage analysis:

Normal stress : 100 % of the specified minimum yield point of the material

Shearing stress : 60 % of the specified minimum yield point of the material

Normal stress is the sum of bending stress and axial stress with the corresponding shearing stress acting perpendicular to the normal stress. No stress concentration factors being taken into account.

(B) For strength assessment with finite element analysis:

Equivalent stress : 100 % of the specified minimum yield point of the material.

For strength calculations by means of finite elements, the geometry is to be idealized as realistically as possible. The ratio of element length to width is not to exceed 3. Girders are to be modelled using shell or plane stress elements. Symmetric girder flanges may be modelled by beam or truss elements. The element height of girder webs must not exceed one-third of the web height. In way of small openings in girder webs the web thickness is to be reduced to a mean thickness over the web height. Large openings are to be modelled. Stiffeners may be modelled by using shell, plane stress, or beam elements. Stresses are to be read from the centre of the individual element. For shell elements the stresses are to be evaluated at the mid plane of the element.

### 6. Safe Working Load (SWL)

- (1) The Safe Working Load (SWL) is the load limit for mooring purpose.
- (2) Unless a greater SWL is requested by the applicant according to **202. 3** (3), the SWL is not to exceed the minimum breaking strength of the mooring line according to **Ch 8, Table 4.8.1**, see Notes in **202. 3**.
- (3) The SWL, in t, of each shipboard fitting is to be marked (by weld bead or equivalent) on the deck fittings used for mooring. For fittings intended to be used for, both, mooring and towing, TOW, in t, according to **201. 6** is to be marked in addition to SWL.
- (4) The above requirements on SWL apply for the use with no more than one mooring line.
- (5) The towing and mooring arrangements plan mentioned in **203.** is to define the method of use of mooring lines.

### 203. Towing and mooring arrangements plan (2018)

1. The SWL and TOW for the intended use for each shipboard fitting is to be noted in the towing and mooring arrangements plan available on board for the guidance of the Master. It is to be noted that TOW is the load limit for towing purpose and SWL that for mooring purpose. If not otherwise chosen, for towing bits it is to be noted that TOW is the load limit for a towing line attached with eye-splice.
2. Information provided on the plan is to include in respect of each shipboard fitting.
  - (1) Location on the ship
  - (2) Fitting type
  - (3) SWL/TOW
  - (4) Purpose (mooring / harbour towing / other towing)
  - (5) Method of applying load of towing or mooring line including limiting fleet angles
 Item (3) with respect to items (4) and (5), is subject to approval by the Society.

Furthermore, information provided on the plan is to include:

- (1) The arrangement of mooring lines showing number of lines (N)
- (2) The minimum breaking strength of each mooring line (MBL)
- (3) The acceptable environmental conditions as given in IACS Recommendation No. 10 “Anchoring, Mooring and Towing Equipment” for the recommended minimum breaking strength of mooring lines for ships with Equipment Number EN > 2000:
  - (A) 30 second mean wind speed from any direction. ( $v_w$  or  $v_w^*$  according to IACS Recommendation No. 10)
  - (B) Maximum current speed acting on bow or stern ( $\pm 10^\circ$ ).
3. The information as given in **2.** is to be incorporated into the pilot card in order to provide the pilot proper information on harbour and other towing operations.

### 204. Corrosion addition (2018)

The corrosion addition,  $t_c$ , is not to be less than the following values:

1. Ships covered by Common Structural Rules for Bulk Carriers and Oil Tankers: Total corrosion additions to be as defined in these rules.
2. Other ships:
  - (1) For the supporting hull structure, according to the Society’s Rules for the surrounding structure (e.g. deck structures, bulwark structures).
  - (2) For pedestals and foundations on deck which are not part of a fitting according to an accepted

industry standard : 2.0 mm.

(3) For shipboard fittings not selected from an accepted industry standard : 2.0 mm.

#### **205. Wear allowance (2018)**

In addition to the corrosion addition given in **204.** the wear allowance,  $t_w$ , for shipboard fittings not selected from an accepted industry standard is not to be less than 1.0 mm, added to surfaces which are intended to regularly contact the line.

#### **206. Survey after construction (2018) [See Guidance]**

The condition of deck fittings, their pedestals or foundations, if any, and the hull structures in the vicinity of the fittings are to be examined in accordance with the Society's Rules.

# CHAPTER 11 ACCESS TO AND WITHIN SPACES IN, AND FORWARD OF, THE CARGO AREA OF OIL TANKERS AND BULK CARRIERS

## Section 1 General

### 101. Application

1. This applies to oil tankers of 500 gross tonnage and over and bulk carriers, as defined in SOLAS Reg. II/1, of 20,000 gross tonnage and over, constructed on or after 1 January 2005. [See Guidance]
2. This do not apply to the cargo tanks of combined chemical/oil tankers complying with the provisions of the IBC Code.

### 102. Means of access to cargo and other spaces [See Guidance]

1. Each space shall be provided with means of access to enable, throughout the life of a ship, overall and close-up inspections and thickness measurements of the ship's structures to be carried out by this Society as necessary. Such means of access shall comply with the requirements of **105.** and **Sec 2.**
2. Where a permanent means of access may be susceptible to damage during normal cargo loading and unloading operations or where it is impracticable to fit permanent means of access, this Society may allow, in lieu thereof, the provision of movable or portable means of access, as specified in the **Sec 2**, provided that the means of attaching, rigging, suspending or supporting the portable means of access forms a permanent part of the ship's structure. All portable equipment shall be capable of being readily erected or deployed by ship's personnel.
3. The construction and materials of all means of access and their attachment to the ship's structure shall be to the satisfaction of this Society. The means of access shall be subject to survey prior to, or in conjunction with, its use in carrying out surveys in accordance with SOLAS I/10.

### 103. Safe access to cargo holds, cargo tanks, ballast tanks and other spaces

[See Guidance]

1. Safe access to cargo holds, cofferdams, ballast tanks, cargo tanks and other spaces in the cargo area shall be direct from the open deck and such as to ensure their complete inspection. Safe access to double bottom spaces or to forward ballast tanks may be from a pump-room, deep cofferdam, pipe tunnel, cargo hold, double hull space or similar compartment not intended for the carriage of oil or hazardous cargoes.
2. Tanks, and subdivisions of tanks, having a length of 35 m or more, shall be fitted with at least two access hatchways and ladders, as far apart as practicable. Tanks less than 35 m in length shall be served by at least one access hatchway and ladder. When a tank is subdivided by one or more swash bulkheads or similar obstructions which do not allow ready means of access to the other parts of the tank, at least two hatchways and ladders shall be fitted.
3. Each cargo hold shall be provided with at least two means of access as far apart as practicable. In general, these accesses should be arranged diagonally, for example one access near the forward bulkhead on the port side, the other one near the aft bulkhead on the starboard side.

### 104. Ship structure access manual [See Guidance]

1. A ship's means of access to carry out overall and close-up inspections and thickness measurements shall be described in a Ship structure access manual approved by this Society, an updated copy of which shall be kept on board. The Ship structure access manual shall include the following for each space ;
  - (1) plans showing the means of access to the space, with appropriate technical specifications and di-

mensions

- (2) plans showing the means of access within each space to enable an overall inspection to be carried out, with appropriate technical specifications and dimensions. The plans shall indicate from where each area in the space can be inspected
  - (3) plans showing the means of access within the space to enable close-up inspections to be carried out, with appropriate technical specifications and dimensions. The plans shall indicate the positions of critical structural areas, whether the means of access is permanent or portable and from where each area can be inspected
  - (4) instructions for inspecting and maintaining the structural strength of all means of access and means of attachment, taking into account any corrosive atmosphere that may be within the space
  - (5) instructions for safety guidance when rafting is used for close-up inspections and thickness measurements
  - (6) instructions for the rigging and use of any portable means of access in a safe manner
  - (7) an inventory of all portable means of access and
  - (8) records of periodical inspections and maintenance of the ship's means of access.
2. For the purpose of this regulation critical structural areas are locations which have been identified from calculations to require monitoring or from the service history of similar or sister ships to be sensitive to cracking, buckling, deformation or corrosion which would impair the structural integrity of the ship.

### 105. General technical specifications [See Guidance]

1. For access through horizontal openings, hatches or manholes, the dimensions shall be sufficient to allow a person wearing a self-contained air-breathing apparatus and protective equipment to ascend or descend any ladder without obstruction and also provide a clear opening to facilitate the hoisting of an injured person from the bottom of the space. The minimum clear opening shall not be less than 600 mm × 600 mm. When access to a cargo hold is arranged through the cargo hatch, the top of the ladder shall be placed as close as possible to the hatch coaming. Access hatch coamings having a height greater than 900 mm shall also have steps on the outside in conjunction with the ladder.
2. For access through vertical openings, or manholes, in swash bulkheads, floors, girders and web frames providing passage through the length and breadth of the space, the minimum opening shall be not less than 600 mm × 800 mm at a height of not more than 600 mm from the bottom shell plating unless gratings or other foot holds are provided.
3. For oil tankers of less than 5,000 tonnes deadweight, this Society may approve, in special circumstances, smaller dimensions for the openings referred to in above **Par 1.** and **2.**, if the ability to traverse such openings or to remove an injured person can be proved to the satisfaction of this Society.

## Section 2 Technical Provisions for Means of Access for Inspections

### 201. Definitions

1. Rung means the step of a vertical ladder or step on the vertical surface. [See Guidance]
2. Tread means the step of an inclined ladder or step for the vertical access opening.
3. Flight of an inclined ladder means the actual stringer length of an inclined ladder. For vertical ladders, it is the distance between the platforms.
4. Stringer means:
  - (1) the frame of a ladder; or
  - (2) the stiffened horizontal plating structure fitted on the side shell, transverse bulkheads and/or longitudinal bulkheads in the space. For the purpose of ballast tanks of less than 5 m width forming double side spaces, the horizontal plating structure is credited as a stringer and a longitudinal permanent means of access, if it provides a continuous passage of 600 mm or more in width past frames or stiffeners on the side shell or longitudinal bulkhead. Openings in stringer

plating utilized as permanent means of access shall be arranged with guard rails or grid covers to provide safe passage on the stringer or safe access to each transverse web.

5. Vertical ladder means a ladder of which the inclined angle is 70° and over up to 90°. A vertical ladder shall not be skewed by more than 2°.
6. Overhead obstructions mean the deck or stringer structure including stiffeners above the means of access.
7. Distance below deck head means the distance below the plating.
8. Cross deck means the transverse area of the main deck which is located inboard and between hatch coamings.

## 202. Technical provisions [See Guidance]

1. Structural members subject to the close-up inspections and thickness measurements of the ship's structure referred to ESP, except those in double bottom spaces, shall be provided with a permanent means of access to the extent as specified in **Table 4.11.1** and **Table 4.11.2**, as applicable. For oil tankers and wing ballast tanks of ore carriers, approved alternative methods may be used in combination with the fitted permanent means of access, provided that the structure allows for its safe and effective use.
2. Permanent means of access should as far as possible be integral to the structure of the ships, thus ensuring that they are robust and at the same time contributing to the overall strength of the structure of the ship.
3. Elevated passageways forming sections of a permanent means of access, where fitted, shall have a minimum clear width of 600 mm, except for going around vertical webs where the minimum clear width may be reduced to 450 mm, and have guard rails over the open side of their entire length. Sloping structures providing part of the access shall be of a non-skid construction. Guard rails shall be 1,000 mm in height and consist of a rail and an intermediate bar 500 mm in height and of substantial construction. Stanchions shall be not more than 3 m apart.
4. Access to permanent means of access and vertical openings from the ship's bottom shall be provided by means of easily accessible passageways, ladders or treads. Treads shall be provided with lateral support for the foot. Where the rungs of ladders are fitted against a vertical surface, the distance from the centre of the rungs to the surface shall be at least 150 mm. Where vertical manholes are fitted higher than 600 mm above the walking level, access shall be facilitated by means of treads and hand grips with platform landings on both sides.
5. Permanent inclined ladders shall be inclined at an angle of less than 70°. There shall be no obstructions within 750 mm of the face of the inclined ladder, except that in way of an opening this clearance may be reduced to 600 mm. Resting platforms of adequate dimensions shall be provided, normally at a maximum of 6 m vertical height. Ladders and handrails shall be constructed of steel or equivalent material of adequate strength and stiffness and securely attached to the structure by stays. The method of support and length of stay shall be such that vibration is reduced to a practical minimum. In cargo holds, ladders shall be designed and arranged so that cargo handling difficulties are not increased and the risk of damage from cargo handling gear is minimized.
6. The width of inclined ladders between stringers shall not be less than 400 mm. The treads shall be equally spaced at a distance apart, measured vertically, of between 200 mm and 300 mm. When steel is used, the treads shall be formed of two square bars of not less than 22 mm by 22 mm in section, fitted to form a horizontal step with the edges pointing upward. The treads shall be carried through the side stringers and attached thereto by double continuous welding. All inclined ladders shall be provided with handrails of substantial construction on both sides, fitted at a convenient distance above the treads.
7. For vertical ladders or spiral ladders, the width and construction should be in accordance with international or national standards accepted by this Society.
8. No free-standing portable ladder shall be more than 5 m long.
9. Alternative means of access include, but are not limited to, such devices as :
  - (1) hydraulic arm fitted with a stable base;

- (2) wire lift platform;
- (3) staging;
- (4) rafting;
- (5) robot arm or remotely operated vehicle (ROV);
- (6) portable ladders more than 5 m long shall only be utilized if fitted with a mechanical device to secure the upper end of the ladder;
- (7) other means of access, approved by and acceptable to this Society.

Means for safe operation and rigging of such equipment to and from and within the spaces shall be clearly described in the Ship Structure Access Manual.

10. For access through horizontal openings, hatches or manholes, the minimum clear opening shall not be less than 600 mm × 600 mm. When access to a cargo hold is arranged through the cargo hatch, the top of the ladder shall be placed as close as possible to the hatch coaming. Access hatch coamings having a height greater than 900 mm shall also have steps on the outside in conjunction with the ladder.
11. For access through vertical openings, or manholes, in swash bulkheads, floors, girders and web frames providing passage through the length and breadth of the space, the minimum opening shall be not less than 600 mm × 800 mm at a height of not more than 600 mm from the passage unless gratings or other foot holds are provided.
12. For oil tankers of less than 5,000 tonnes deadweight, this Society may approve, in special circumstances, smaller dimensions for the openings referred to in paragraphs **Par 10.** and **11.**, if the ability to traverse such openings or to remove an injured person can be proved to the satisfaction of this Society.
13. For bulk carriers, access ladders to cargo holds and other spaces shall be :
  - (1) Where the vertical distance between the upper surface of adjacent decks or between deck and the bottom of the cargo space is not more than 6 m, either a vertical ladder or an inclined ladder.
  - (2) Where the vertical distance between the upper surface of adjacent decks or between deck and the bottom of the cargo space is more than 6 m, an inclined ladder or series of inclined ladders at one end of the cargo hold, except the uppermost 2.5 m of a cargo space measured clear of overhead obstructions and the lowest 6 m may have vertical ladders, provided that the vertical extent of the inclined ladder or ladders connecting the vertical ladders is not less than 2.5 m. The second means of access at the other end of the cargo hold may be formed of a series of staggered vertical ladders, which should comprise of one or more ladder linking platforms spaced not more than 6 m apart vertically and displaced to one side of the ladder. Adjacent sections of ladder should be laterally offset from each other by at least the width of the ladder. The uppermost entrance section of the ladder directly exposed to a cargo hold should be vertical for a distance of 2.5 m measured clear of overhead obstructions and connected to a ladder-linking platform.
  - (3) A vertical ladder may be used as a means of access to topside tanks, where the vertical distance is 6 m or less between the deck and the longitudinal means of access in the tank or the stringer or the bottom of the space immediately below the entrance. The uppermost entrance section from deck of the vertical ladder of the tank should be vertical for a distance of 2.5 m measured clear of overhead obstructions and comprise a ladder linking platform, unless landing on the longitudinal means of access, the stringer or the bottom within the vertical distance, displaced to one side of a vertical ladder.
  - (4) An inclined ladder or combination of ladders should be used for access to a tank or a space where the vertical distance is greater than 6 m between the deck and a stringer immediately below the entrance, between stringers, or between the deck or a stringer and the bottom of the space immediately below the entrance.
  - (5) In case of (4) above, the uppermost entrance section from deck of the ladder should be vertical for a distance of 2.5 m clear of overhead obstructions and connected to a landing platform and continued with an inclined ladder. The flights of inclined ladders should not be more than 9 m in actual length and the vertical height should not normally be more than 6 m. The lowermost section of the ladders may be vertical for a distance of not less than 2.5 m.
  - (6) In double-side skin spaces of less than 2.5 m width, the access to the space may be by means of vertical ladders that comprise of one or more ladder linking platforms spaced not more than 6 m apart vertically and displaced to one side of the ladder. Adjacent sections of ladder should

be laterally offset from each other by at least the width of the ladder.

(7) A spiral ladder is considered acceptable as an alternative for inclined ladders. In this regard, the uppermost 2.5 m can continue to be comprised of the spiral ladder and need not change over to vertical ladders.

14. The uppermost entrance section from deck of the vertical ladder providing access to a tank should be vertical for a distance of 2.5 m measured clear of overhead obstructions and comprise a ladder linking platform, displaced to one side of a vertical ladder. The vertical ladder can be between 1.6 m and 3 m below deck structure if it lands on a longitudinal or athwartship permanent means of access fitted within that range.

### **203. Protective coating [See Guidance]**

Permanent means of access in dedicated seawater ballast tanks in all types of ships and double-side skin spaces of bulk carriers shall be coated in accordance with the Guidance relating to the Rules specified by the Society.

**Table 4.11.1 – Means of access for ballast and cargo tanks of oil tankers  
(Access to the underdeck and vertical structure)**

<p><b>1. Water ballast tanks, except those specified in 2., and cargo oil tanks</b></p> <p>1.1 For tanks of which the height is 6 m and over containing internal structures, permanent means of access shall be provided in accordance with .1 to .6:</p> <ol style="list-style-type: none"> <li>.1 continuous athwartship permanent access arranged at each transverse bulkhead on the stiffened surface, at a minimum of 1.6 m to a maximum of 3 m below the deck head;</li> <li>.2 at least one continuous longitudinal permanent means of access at each side of the tank. One of these accesses shall be at a minimum of 1.6 m to a maximum of 6 m below the deck head and the other shall be at a minimum of 1.6 m to a maximum of 3 m below the deck head;</li> <li>.3 access between the arrangements specified in .1 and .2 and from the main deck to either .1 or .2;</li> <li>.4 continuous longitudinal permanent means of access which are integrated in the structural member on the stiffened surface of a longitudinal bulkhead, in alignment, where possible, with horizontal girders of transverse bulkheads are to be provided for access to the transverse webs unless permanent fittings are installed at the uppermost platform for use of alternative means, as defined in <b>202. 9</b> of the Technical provisions, for inspection at intermediate heights;</li> <li>.5 for ships having cross-ties which are 6 m or more above tank bottom, a transverse permanent means of access on the cross-ties providing inspection of the tie flaring brackets at both sides of the tank, with access from one of the longitudinal permanent means of access in .4; and</li> <li>.6 alternative means as defined in 202. 9. of the technical provisions may be provided for small ships as an alternative to .4 for cargo oil tanks of which the height is less than 17 m.</li> </ol> <p>1.2 For tanks of which the height is less than 6 m, alternative means as defined in <b>202. 9</b> of the technical provisions or portable means may be utilized in lieu of the permanent means of access.</p> <p><b>Fore peak tanks</b></p> <p>1.3 For fore peak tanks with a depth of 6 m or more at the centre line of the collision bulkhead, a suitable means of access shall be provided for access to critical areas such as the underdeck structure, stringers, collision bulkhead and side shell structure.</p> <p>1.3.1 Stringers of less than 6 m in vertical distance from the deck head or a stringer immediately above are considered to provide suitable access in combination with portable means of access.</p> <p>1.3.2 In case the vertical distance between the deck head and stringers, stringers or the lowest stringer and the tank bottom is 6 m or more, alternative means of access as defined in 202. 9. of the Technical provisions shall be provided.</p>
<p><b>2. Water ballast wing tanks of less than 5 m width forming double side spaces and their bilge hopper sections</b></p> <p>2.1 For double side spaces above the upper knuckle point of the bilge hopper sections, permanent means of access are to be provided in accordance with .1 to .3:</p> <ol style="list-style-type: none"> <li>.1 where the vertical distance between horizontal uppermost stringer and deck head is 6 m or more, one continuous longitudinal permanent means of access shall be provided for the full length of the tank with a means to allow passing through transverse webs installed at a minimum of 1.6 m to a maximum of 3 m below the deck head with a vertical access ladder at each end of the tank;</li> <li>.2 continuous longitudinal permanent means of access, which are integrated in the structure, at a vertical distance not exceeding 6 m apart but permitted to exceed 6 m by a maximum of 10 %; and</li> <li>.3 plated stringers shall, as far as possible, be in alignment with horizontal girders of transverse bulkheads.</li> </ol> <p>2.2 For bilge hopper sections of which the vertical distance from the tank bottom to the upper knuckle point is 6 m and over, one longitudinal permanent means of access shall be provided for the full length of the tank. It shall be accessible by vertical permanent means of access at each end of the tank.</p> <p>2.2.1 The longitudinal continuous permanent means of access may be installed at a minimum 1.6 m to maximum 3 m from the top of the bilge hopper section. In this case, a platform extending the longitudinal continuous permanent means of access in way of the webframe may be used to access the identified structural critical areas.</p> <p>2.2.2 Alternatively, the continuous longitudinal permanent means of access may be installed at a minimum of 1.2 m below the top of the clear opening of the web ring allowing a use of portable means of access to reach identified structural critical areas.</p> <p>2.3 Where the vertical distance referred to in 2.2 is less than 6 m, alternative means as defined in <b>202. 9</b> of the technical provisions or portable means of access may be utilised in lieu of the permanent means of access. To facilitate the operation of the alternative means of access, in-line openings in horizontal stringers shall be provided. The openings shall be of an adequate diameter and shall have suitable protective railings.</p>

Table 4.11.2 Means of access for bulk carriers

<p><b>1. Cargo holds</b></p> <p><b>Access to underdeck structure</b></p> <p>1.1 Permanent means of access shall be fitted to provide access to the overhead structure at both sides of the cross deck and in the vicinity of the centreline. Each means of access shall be accessible from the cargo hold access or directly from the main deck and installed at a minimum of 1.6 m to a maximum of 3 m below the deck.</p> <p>1.2 An athwartship permanent means of access fitted on the transverse bulkhead at a minimum 1.6 m to a maximum 3 m below the cross-deck head is accepted as equivalent to 1.1.</p> <p>1.3 Access to the permanent means of access to overhead structure of the cross deck may also be via the upper stool.</p> <p>1.4 Ships having transverse bulkheads with full upper stools with access from the main deck which allows monitoring of all framing and plates from inside do not require permanent means of access of the cross deck.</p> <p>1.5 Alternatively, movable means of access may be utilized for access to the overhead structure of the cross deck if its vertical distance is 17 m or less above the tank top.</p> <p><b>Access to vertical structures</b></p> <p>1.6 Permanent means of vertical access shall be provided in all cargo holds and built into the structure to allow for an inspection of a minimum of 25 % of the total number of hold frames port and starboard equally distributed throughout the hold including at each end in way of transverse bulkheads. But in no circumstance shall this arrangement be less than 3 permanent means of vertical access fitted to each side (fore and aft ends of hold and mid-span). Permanent means of vertical access fitted between two adjacent hold frames is counted for an access for the inspection of both hold frames. A means of portable access may be used to gain access over the sloping plating of lower hopper ballast tanks.</p> <p>1.7 In addition, portable or movable means of access shall be utilized for access to the remaining hold frames up to their upper brackets and transverse bulkheads.</p> <p><b>Access to vertical structures</b></p> <p>1.8 Portable or movable means of access may be utilized for access to hold frames up to their upper bracket in place of the permanent means required in 1.6. These means of access shall be carried on board the ship and readily available for use.</p> <p>1.9 The width of vertical ladders for access to hold frames shall be at least 300 mm, measured between stringers.</p> <p>1.10 A single vertical ladder over 6 m in length is acceptable for the inspection of the hold side frames in a single skin construction.</p> <p>1.11 For double-side skin construction no vertical ladders for the inspection of the cargo hold surfaces are required. Inspection of this structure should be provided from within the double hull space.</p>
---

Table 4.11.2 Means of access for bulk carriers (continued)

<p><b>2. Ballast tanks</b></p> <p><b>Top side tanks</b></p> <p>2.1 For each topside tank of which the height is 6 m and over, one longitudinal continuous permanent means of access shall be provided along the side shell webs and installed at a minimum of 1.6 m to a maximum of 3 m below deck with a vertical access ladder in the vicinity of each access to that tank.</p> <p>2.2 If no access holes are provided through the transverse webs within 600 mm of the tank base and the web frame rings have a web height greater than 1 m in way of side shell and sloping plating, then step rungs/grab rails shall be provided to allow safe access over each transverse web frame ring.</p> <p>2.3 Three permanent means of access, fitted at the end bay and middle bay of each tank, shall be provided spanning from tank base up to the intersection of the sloping plate with the hatch side girder. The existing longitudinal structure, if fitted on the sloping plate in the space may be used as part of this means of access.</p> <p>2.4 For topside tanks of which the height is less than 6 m, alternative means as defined in paragraph <b>202. 9</b> of the technical provisions or portable means may be utilized in lieu of the permanent means of access.</p> <p><b>Bilge hopper tanks</b></p> <p>2.5 For each bilge hopper tank of which the height is 6 m and over, one longitudinal continuous permanent means of access shall be provided along the side shell webs and installed at a minimum of 1.2 m below the top of the clear opening of the web ring with a vertical access ladder in the vicinity of each access to the tank.</p> <p>2.5.1 An access ladder between the longitudinal continuous permanent means of access and the bottom of the space shall be provided at each end of the tank.</p> <p>2.5.2 Alternatively, the longitudinal continuous permanent means of access can be located through the upper web plating above the clear opening of the web ring, at a minimum of 1.6 m below the deck head, when this arrangement facilitates more suitable inspection of identified structurally critical areas. An enlarged longitudinal frame can be used for the purpose of the walkway.</p> <p><b>Bilge hopper tanks</b></p> <p>2.5.3 For double-side skin bulk carriers, the longitudinal continuous permanent means of access may be installed within 6 m from the knuckle point of the bilge, if used in combination with alternative methods to gain access to the knuckle point.</p> <p>2.6 If no access holes are provided through the transverse ring webs within 600 mm of the tank base and the web frame rings have a web height greater than 1 m in way of side shell and sloping plating, then step rungs/grab rails shall be provided to allow safe access over each transverse web frame ring.</p> <p>2.7 For bilge hopper tanks of which the height is less than 6 m, alternative means as defined in paragraph <b>202. 9</b> of the technical provisions or portable means may be utilized in lieu of the permanent means of access. Such means of access shall be demonstrated that they can be deployed and made readily available in the areas where needed.</p> <p><b>Double-skin side tanks</b></p> <p>2.8 Permanent means of access shall be provided in accordance with the applicable sections of <b>Table 4.11.1</b>.</p> <p><b>For Fore peak tanks</b></p> <p>2.9 For fore peak tanks with a depth of 6 m or more at the centreline of the collision bulkhead, a suitable means of access shall be provided for access to critical areas such as the underdeck structure, stringers, collision bulkhead and side shell structure.</p> <p>2.9.1 Stringers of less than 6 m in vertical distance from the deck head or a stringer immediately above are considered to provide suitable access in combination with portable means of access.</p> <p>2.9.2 In case the vertical distance between the deck head and stringers, stringers or the lowest stringer and the tank bottom is 6 m or more, alternative means of access as defined in paragraph <b>202. 9</b> of the Technical provisions shall be provided.</p>
---

\* For ore carriers, permanent means of access shall be provided in accordance with the applicable sections of **Table 4.11.1** and **Table 4.11.2**. ↓



**2019**

**Guidance Relating to  
the Rules for the Classification of Steel Ships**

---

**Part 4**

**Hull Equipment**

#### APPLICATION OF THE GUIDANCE RELATING TO THE RULES

This "Guidance Relating to the Rules for the Classification of Steel Ships" (hereafter called as the Guidance Relating to the Rules) is prepared with the intent of giving details as to the treatment of the various provisions for items required the unified interpretations and items not specified in the Rules, and the requirements specified in the Guidance Relating to the Rules are to be applied, in principle, in addition to the various provisions in the Rules.

As to any technical modifications which can be regarded as equivalent to any requirements in the Guidance Relating to the Rules, their flexible application will be properly considered.

## **APPLICATION OF PART 4 "HULL EQUIPMENT"**

1. Unless expressly specified otherwise, the requirements in the Guidance apply to ships for which contracts for construction are signed on or after 1 July 2019.
2. The amendments to the Guidance for 2018 edition and their effective date are as follows;

**Effective Date : 1 July 2019**

---

### **Chapter 1 RUDDERS**

- Section 4 Rudder Strength Calculation  
- 401. 4. (2), 7. (5) & Fig 4.1.3 have been amended.

### **Chapter 4 BULWARKS, FREEING PORTS, SIDE SCUTTLES, RECTANGULAR WINDOWS, VENTILATORS AND PERMANENT GANGWAYS**

- Section 2 Freeing Ports  
- 202. 9. has been newly added.

### **Chapter 8 EQUIPMENT NUMBER AND EQUIPMENT**

- Section 1 General  
- 101. 4. (1) has been amended.

### **Chapter 10 SHIPBOARD EQUIPMENT, FITTINGS AND SUPPORTING HULL STRUCTURES ASSOCIATED WITH TOWING AND MOORING**

- Section 1 Definitions and Scope of Application  
- 101. 2. (1) (G) & 6. (3) (C) have been amended.

### **Chapter 11 ACCESS TO AND WITHIN SPACES IN, AND FORWARD OF, THE CARGO AREA OF OIL TANKERS AND BULK CARRIERS**

- Section 1 General  
- 103. 2. & 104. 2. (2) have been amended.

### **Annex 4-3 Anchoring in Deep and Unsheltered Waters**

- newly added.

# CONTENTS

<b>CHAPTER 1 RUDDERS</b> .....	<b>1</b>
Section 1 General .....	1
Section 4 Rudder Strength Calculation .....	2
Section 5 Rudder Stocks .....	10
Section 6 Rudder Plates, Rudder Frames and Rudder Main Pieces .....	11
Section 7 Couplings between Rudder Stocks and Main Pieces .....	12
Section 8 Pintles .....	13
Section 9 Bearings of Rudders Stock and Pintles .....	13
Section 10 Rudder Accessories .....	14
Section 11 Propeller Nozzles .....	15
<b>CHAPTER 2 HATCHWAYS AND OTHER DECK OPENINGS</b> .....	<b>17</b>
Section 1 General .....	17
Section 2 Design Load .....	18
Section 3 Hatch cover strength criteria .....	18
Section 5 Hatch cover details - Closing Arrangement, Securing Devices and Stoppers .....	19
Section 7 Miscellaneous Openings .....	19
<b>CHAPTER 3 BOW DOORS, SIDE AND STERN DOORS</b> .....	<b>21</b>
Section 1 Bow Doors and Inner Doors .....	21
Section 2 Side Shell Doors and Stern Doors .....	22
<b>CHAPTER 4 BULWARKS, FREEING PORTS, SIDE SCUTTLES, RECTANGULAR WINDOWS, SKYLIGHTS, VENTILATORS AND PERMANENT GANGWAYS</b> .....	<b>23</b>
Section 1 Bulwarks and Guardrails .....	23
Section 2 Freeing Ports .....	24
Section 3 Side Scuttles, Rectangular Windows and Skylights .....	26
Section 4 Ventilators .....	29
Section 5 Permanent Gangways .....	29
<b>CHAPTER 7 CEMENTING AND PAINTING</b> .....	<b>33</b>
<b>CHAPTER 8 EQUIPMENT NUMBER AND EQUIPMENT</b> .....	<b>35</b>
Section 1 General .....	35
Section 2 Equipment Number .....	36
Section 3 Anchors .....	42
Section 4 Chains .....	42
Section 5 Steel Wire Ropes .....	58
Section 7 Hatch Tarpaulins .....	58
Section 9 Rectangular Windows .....	58

<b>CHAPTER 9 STRENGTH AND SECURING OF SMALL HATCHES, FITTINGS AND EQUIPMENT ON THE FORE DECK .....</b>	<b>59</b>
Section 2 Strength and Securing of Small Hatches on the Exposed Fore Deck .....	59
<b>CHAPTER 10 SHIPBOARD EQUIPMENT, FITTINGS AND SUPPORTING HULL STRUCTURES ASSOCIATED WITH TOWING AND MOORING .....</b>	<b>61</b>
Section 1 Definitions and Scope of Application .....	61
Section 2 Towing and Mooring .....	65
<b>CHAPTER 11 ACCESS TO AND WITHIN SPACES IN, AND FORWARD OF, THE CARGO AREA OF OIL TANKERS AND BULK CARRIERS .....</b>	<b>67</b>
Section 1 General .....	67
Section 2 Technical Provisions for Means of Access for Inspections .....	70
<b>&lt;ANNEX&gt;</b>	
Annex 4-1 Means of Access for Ballast and Cargo Tanks of Oil Tankers .....	81
Annex 4-2 Means of Access for Bulk Carriers .....	85
Annex 4-3 Anchoring in Deep and Unsheltered Waters .....	89

# CHAPTER 1 RUDDERS

## Section 1 General

### 101. Application [See Rule]

#### 1. Rudders having three or more pintles

The scantling of each member of rudders having three or more pintles is to be determined in accordance with the requirements in the **Pt 4, Ch 1** of the Rules correspondingly. However, the moment and the force acting on each member are to be determined by the direct calculation method, in accordance with the requirements in **Sec 4** of the Guidance.

#### 2. Nozzle rudders

Nozzle rudders are to be as specified in (1) and (2) below respectively, unless the rudder force and rudder torque are required to be determined by tests or detailed theoretical calculation.

In other rudders, the scantling of each member is to be determined by obtaining the rudder force and rudder torque through tests or detailed theoretical calculations, and correspondingly applying the requirements in **Pt 4, Ch 1** of the Rules. Results of tests or theoretical calculations are to be submitted to the Society.

(1) The scantling of each member of a nozzle rudder with flaps and fish tail rudders is to be determined in accordance with the requirements in **Pt 4, Ch 1** of the Rules. In applying the Rules, however, values of factor  $K_2$  in **Sec 2** are 1.9 for ahead, 1.5 for astern and values of factor  $\alpha$  in **Sec 3** are to be in accordance with the discretion of the Society.

(2) Nozzle rudder area

In applying the Rules, the total rudder area and the rudder area ahead of the centreline of the rudder stock are to be calculated as follows:

$$\text{Total rudder area } (A) : 2h(b_1 + b_2) + \Sigma h' (a_1 + a_2) \quad (\text{m}^2)$$

$$\text{Rudder area ahead of the centreline of the rudder stock } (A_f) : 2hb_2 \quad (\text{m}^2)$$

$a_1, a_2, b_1, b_2, h$  and  $h'$  = as specified in **Fig 4.1.1**

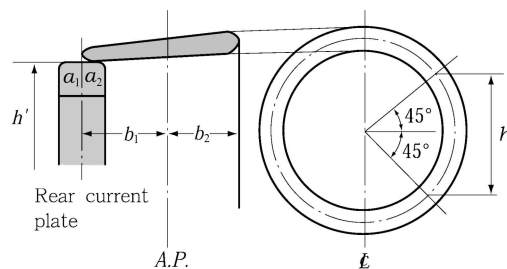


Fig 4.1.1 Nozzle rudder area

#### 3. Rudders designed for helm angle exceeding 35°

The scantling of each member of a rudder designed for helm angle exceeding 35° is to be determined in accordance with the requirements in **Pt 4, Ch 1** of the Rules correspondingly, on the basis of the rudder force and rudder torque obtained through tests or detailed theoretical calculations. The results of tests and theoretical calculations are to be submitted to the Society.

4. For the single plate rudder, 1.0 may be taken as a coefficient  $K_2$  for the ahead and astern conditions.

5. For the Type *C* rudders, safety devices (eg: Locking Ring, Nut Stopper, Nut Lock, etc.) are to be provided to prevent unwinding of the rudders. (2017)

103. Materials [See Rule]

1. If the diameter of rudder stock is small, cast carbon steel is not to be used.
2. Rolled bar steel (*RSFB 45*) may be treated in the same way as forging steel (*RSF 45*)

**Section 4 Rudder Strength Calculation**

401. Rudder strength calculation [See Rule]

1. General

The bending moment, shear force, and supporting force acting on the rudder and rudder stock may be evaluated using the basic rudder models as outlined in 3 to 7.

2. Moments and forces to be evaluated

The bending moment  $M_R$  and the shear force  $Q_1$  acting on the rudder body, the bending moment  $M_b$  acting on the bearing, and the bending moment  $M_s$  acting on the coupling between the rudder stock and rudder main piece and the supporting force  $B_1, B_2, B_3$  are to be obtained and to be used for analyzing the stresses in accordance with the **Pt 4, Ch 1** of the Rules.

3. Type C rudders(Spade rudder)

(1) General data

The data on the spade rudder models is as follows(See **Fig 4.1.2** of the Guidance):

$\ell_{10} \sim \ell_{30}$  = Lengths of the individual girders of the system (m)

$I_{10} \sim I_{30}$  = Moments of inertia of these girders ( $\text{cm}^4$ )

Load of rudder body

$$P_R = \frac{F_R}{1000 \ell_{10}} \quad (\text{kN/m})$$

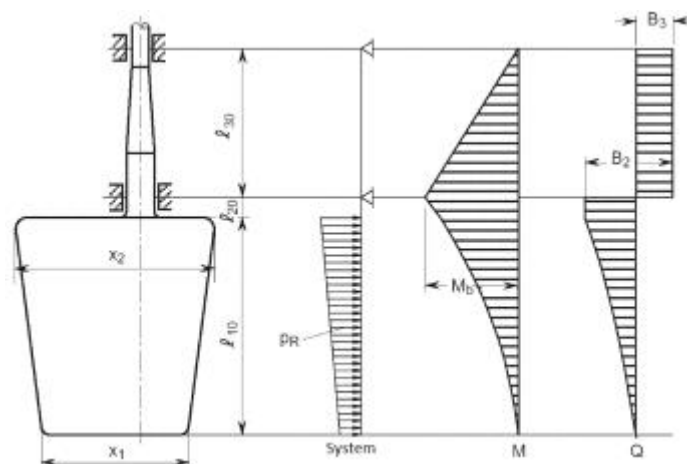
$F_R$  : as specified in **Pt 4, Ch 1, Sec 2** of the Rules

(2) The moments and forces may be determined by the following formulae:

$$M_b = F_R \left[ \ell_{20} + \frac{\ell_{10}(2x_1 + x_2)}{3(x_1 + x_2)} \right] \quad (\text{N-m})$$

$$B_2 = F_R + B_3 \quad (\text{N})$$

$$B_3 = \frac{M_b}{l_{30}} \quad (\text{N})$$



**Fig 4.1.2 Type C rudder (Spade rudder)**

#### 4. Spade rudder with trunk

(1) General data

The data on the spade rudder with trunk models is as follows(See **Fig 4.1.3** of the Guidance):

$\ell_{10} \sim \ell_{30}$  = Lengths of the individual girders of the system (m)

$I_{10} \sim I_{30}$  = Moments of inertia of these girders (cm<sup>4</sup>)

Load of rudder body

$$P_R = \frac{F_R}{1000(\ell_{10} + \ell_{20})} \quad (\text{kN/m})$$

$F_R$  : as specified in **Pt 4, Ch 1, Sec 2** of the Rules

(2) For spade rudders with rudders trunks the moments and forces may be determined by the following formulae: (2019)

$M_R$  is the greatest of the following values:

$$M_{FR1} = F_{R1}(CG_{1Z} - \ell_{10}) \quad (\text{N-m})$$

$$M_{FR2} = F_{R2}(\ell_{10} - CG_{2Z}) \quad (\text{N-m})$$

$F_{R1}$  : Rudder force over the rudder blade area  $A_1$

$F_{R2}$  : Rudder force over the rudder blade area  $A_2$

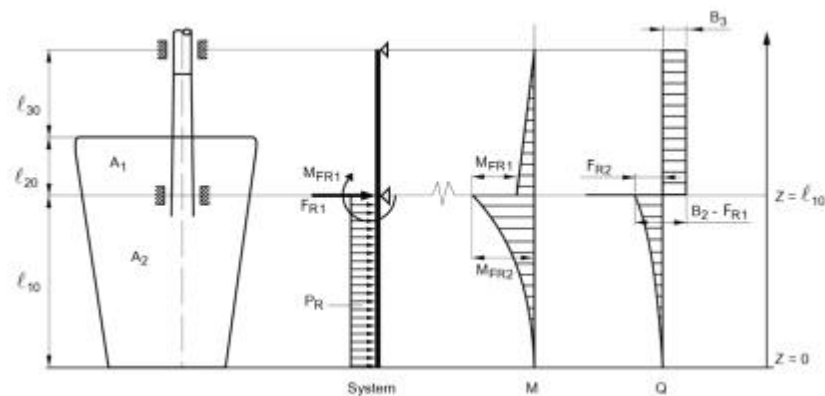
$CG_{1Z}$  : Vertical position of the centre of gravity of the rudder blade area  $A_1$  from base

$CG_{2Z}$  : Vertical position of the centre of gravity of the rudder blade area  $A_2$  from base

$$F_R = F_{R1} + F_{R2} \quad (\text{N})$$

$$B_2 = F_R + B_3 \quad (\text{N})$$

$$B_3 = (M_{FR2} - M_{FR1}) / (\ell_{20} + \ell_{30}) \quad (\text{N})$$



**Fig 4.1.3 Spade rudder with trunk (2019)**

#### 5. Type B rudders(Rudder supported by sole piece)

(1) General data

The data on the rudder supported by sole piece models is as follows(See **Fig 4.1.4** of the Guidance):

$\ell_{10} \sim \ell_{50}$  = Lengths of the individual girders of the system (m)

$I_{10} \sim I_{50}$  = Moments of inertia of these girders (cm<sup>4</sup>)

For rudders supported by a sole piece the length  $\ell_{20}$  is the distance between lower edge of rudder body and centre of sole piece and  $I_{20}$  the moment of inertia of the pintle in the sole piece.

$I_{50}$  = Moments of inertia of sole piece around the z-axis (cm<sup>4</sup>)  
 $\ell_{50}$  = Effective length of sole piece (m)

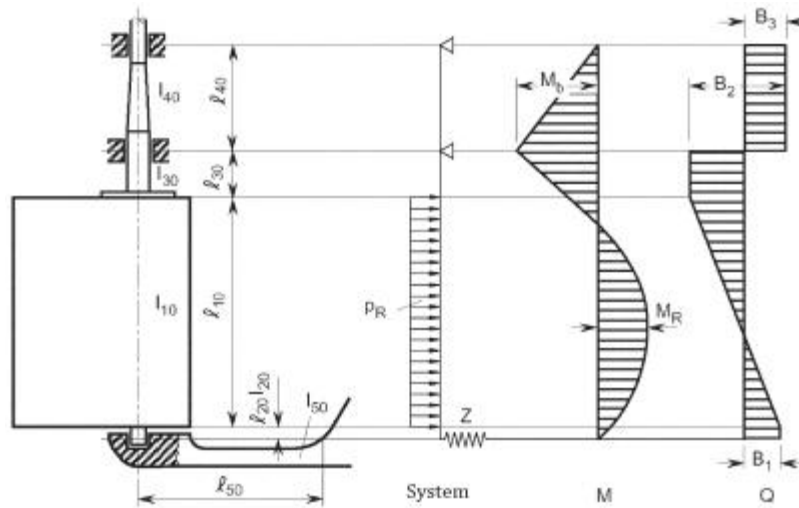


Fig 4.1.4 Type B rudder(Rudder supported by sole piece)

Load of rudder body

$$P_R = \frac{F_R}{1000 \ell_{10}} \quad (\text{kN/m})$$

$F_R$  : as specified in Pt 4, Ch 1, Sec 2 of the Rules

$Z$  is spring constant of support in the sole piece, obtained from the following formula.

$$Z = \frac{6.18 I_{50}}{\ell_{50}^3} \quad (\text{kN/m})$$

- (2) The moments and forces may be determined by an approximate simplified method given in Fig 4.1.4 of the Guidance)

## 6. Type D rudders(Semi spade rudder with one elastic support)

- (1) General data

The data on the semi spade rudder with one elastic support models is as follows(See Fig 4.1.5 of the Guidance):

$\ell_{10} \sim \ell_{50}$  = Lengths of the individual girders of the system (m)

$I_{10} \sim I_{50}$  = Moments of inertia of these girders (cm<sup>4</sup>)

$Z$  is spring constant of support in the rudder horn, obtained from the following formula.

$$Z = \frac{1}{f_b + f_t} \quad (\text{kN/m})$$

$f_b$  is unit displacement of rudder horn(m) due to a unit force of 1 kN acting in the centre of support, obtained from the following formula.

$$f_b = \frac{1.3 d^3}{6.18 I_n} \quad (\text{m/kN})$$

$I_n$  : Moments of inertia of rudder horn around the x-axis (cm<sup>4</sup>)

$f_t$  is unit displacement due to torsion, obtained from the following formula.

$$f_t = \frac{de^2 \sum u_i/t_i}{3.14 \cdot 10^8 F_T^2} \quad (\text{m/kN})$$

$F_T$  : mean sectional area of rudder horn ( $\text{m}^2$ )

$u_i$  : breadth of the individual plates forming the mean horn sectional area (mm)

$t_i$  : thickness within the individual breadth  $u_i$  (mm)

$d$  : Height of the rudder horn defined in **Fig 4.1.5** of the Guidance. This value is measured downwards from the upper rudder horn end, at the point of curvature transition, to the mid-line of the lower rudder horn pintle (m)

$e$  : distance as defined in **Fig 4.1.6** of the Guidance.

Load of rudder body

$$P_{R10} = \frac{F_{R2}}{1000 \ell_{10}} \quad (\text{kN/m})$$

$$P_{R20} = \frac{F_{R1}}{1000 \ell_{20}} \quad (\text{kN/m})$$

$F_{R1}$  and  $F_{R2}$  : as specified in **Pt 4, Ch 1, Sec 2** of the Rules

(2) The moments and forces may be determined by the following formulae: (2018)

$$M_R = \frac{F_{R2} l_{10}}{2} \quad (\text{N-m})$$

$$M_b = \frac{F_R l_{10}^2}{10(l_{20} + l_{30})} \quad (\text{N-m})$$

$$M_s = \frac{2M_R l_{10} l_{30}}{(l_{20} + l_{30})^2} \quad (\text{N-m})$$

$$B_1 = \frac{F_R h_c}{l_{20} + l_{30}} \quad (\text{N})$$

$$B_2 = F_R - B_1, \quad \min B_2 = F_R/4 \quad (\text{N})$$

$$B_3 = \frac{M_b}{l_{40}} \quad (\text{N})$$

$$Q_1 = F_{R2} \quad (\text{N})$$

(3) The loads on the rudder horn are as follows(See **Fig 4.1.6** of the Guidance):

$M_b$  is bending moment, obtained from the following formula.

$$M_b = B_1 z \quad (\text{N-m})$$

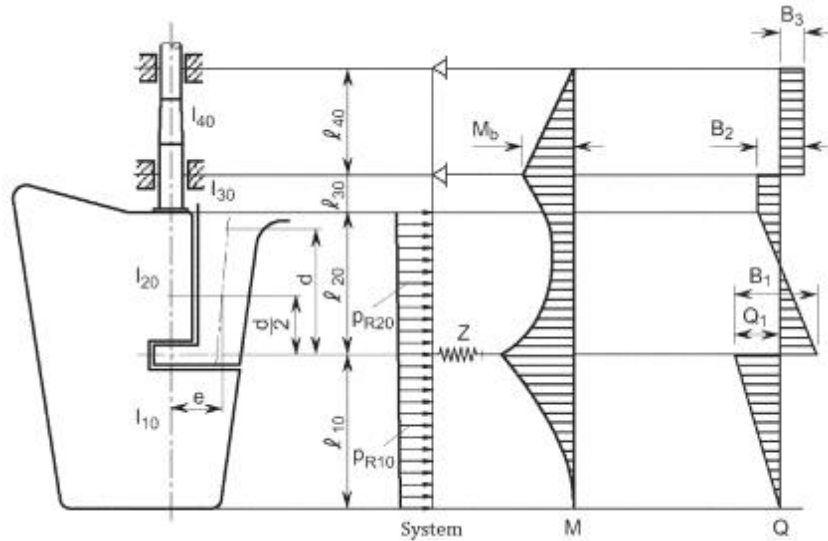
$$M_{bmax} = B_1 d \quad (\text{N-m})$$

$Q$  is shear force and to be taken as  $B_1$ , obtained from the following formula.

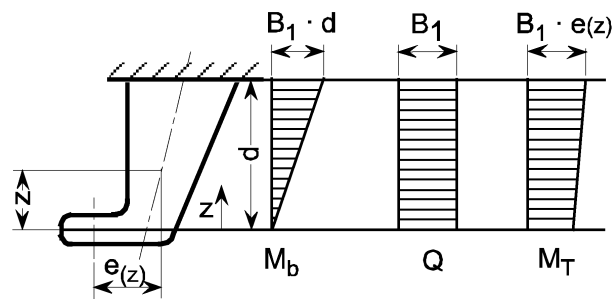
$$B_1 = \frac{F_R b}{(l_{20} + l_{30})} \quad (\text{N})$$

$M_{T(z)}$  is torsional moment, obtained from the following formula.

$$M_{T(z)} = B_1 e_{(z)} \quad (\text{N-m})$$



**Fig 4.1.5 Type D rudder**  
(Semi spade rudder with one elastic support)



**Fig 4.1.6 Rudder horn**

**7. Type E rudders(Semi spade rudder with 2-conjugate elastic support)**

(1) General data

The data on the semi spade rudder with 2-conjugate elastic support models is as follows(See **Fig 4.1.7** and **Fig 4.1.8** of the Guidance):

$K_{11}, K_{22}, K_{12}$  : Rudder horn compliance constants calculated for rudder horn with 2-conjugate elastic supports

The 2-conjugate elastic supports are defined in terms of horizontal displacements,  $y_i$ , by the following equations:

at the lower rudder horn bearing:  $y_1 = K_{12}B_2 - K_{22}B_1$

at the upper rudder horn bearing:  $y_2 = K_{11}B_2 - K_{12}B_1$

$y_1, y_2$  : Horizontal displacements at the lower and upper rudder horn bearings, respectively (m)

$B_1, B_2$  : Horizontal support forces at the lower and upper rudder horn bearings, respectively (kN)

$K_{11}, K_{22}, K_{12}$ : Obtained, in m/kN, from the following formulae:

$$K_{11} = 1.3 \frac{\lambda^3}{3EJ_{lh}} + \frac{e^2\lambda}{GJ_{lh}}$$

$$K_{22} = 1.3 \left[ \frac{\lambda^3}{3EJ_{1h}} + \frac{\lambda^2(d-\lambda)}{2EJ_{1h}} \right] + \frac{e^2\lambda}{GJ_{th}}$$

$$K_{12} = 1.3 \left[ \frac{\lambda^3}{3EJ_{1h}} + \frac{\lambda^2(d-\lambda)}{EJ_{1h}} + \frac{\lambda(d-\lambda)^2}{EJ_{1h}} + \frac{(d-\lambda)^3}{3EJ_{2h}} \right] + \frac{e^2d}{GJ_{th}}$$

$d$  : Height of the rudder horn, in m, defined in **Fig 4.1.7** of the Guidance. This value is measured downwards from the upper rudder horn end, at the point of curvature transition, to the mid-line of the lower rudder horn pintle.

$\lambda$  : Length, in m, as defined **Fig 4.1.7** of the Guidance. This length is measured downwards from the upper rudder horn end, at the point of curvature transition, to the mid-line of the upper rudder horn bearing. For  $\lambda = 0$ , the above formulae converge to those of spring constant  $Z$  for a rudder horn with 1-elastic support, and assuming a hollow cross section for this part.

$e$  : Rudder-horn torsion lever, in m, as defined in **Fig 4.1.7** of the Guidance (value taken at  $z = d/2$ )

$J_{1h}$  : Moment of inertia of rudder horn about the  $x$  axis, in  $m^4$ , for the region above the upper rudder horn bearing. Note that  $J_{1h}$  is an average value over the length  $\lambda$  (see **Fig 4.1.7** of the Guidance)

$J_{2h}$  : Moment of inertia of rudder horn about the  $x$  axis, in  $m^4$ , for the region between the upper and lower rudder horn bearings. Note that  $J_{2h}$  is an average value over the length  $d - \lambda$  (see **Fig 4.1.7** of the Guidance)

$J_{th}$  : Torsional stiffness factor of the rudder horn( $m^4$ ), For any thin wall closed section:

$$J_{th} = \frac{4F_T^2}{\sum_i \frac{u_i}{t_i}}$$

$F_T$  : Mean of areas enclosed by outer and inner boundaries of the thin walled section of rudder horn( $m^2$ )

$u_i$  : Length of the individual plates forming the mean horn sectional area.(mm)

$t_i$  : Thickness, in mm, of the individual plates mentioned above.(mm)

Note that the  $J_{th}$  value is taken as an average value, valid over the rudder horn height.

Load of rudder body

$$P_{R10} = \frac{F_{R2}}{1000 \ell_{10}} \quad (\text{kN/m})$$

$$P_{R20} = \frac{F_{R1}}{1000 \ell_{20}} \quad (\text{kN/m})$$

$F_{R1}$  and  $F_{R2}$  : as specified in **Pt 4, Ch 1, Sec 2** of the Rules

(2) The moments and forces may be determined by an approximate simplified method given in **Fig 4.1.7** of the Guidance)

(3) Rudder horn bending moment

The bending moment acting on the generic section of the rudder horn is to be obtained from the following formulae:

between the lower and upper supports provided by the rudder horn:

$$M_H = F_{A1} z \quad (\text{N-m})$$

above the rudder horn upper-support:

$$M_H = F_{A1}z + F_{A2}(z - d_{lu}) \quad (\text{N-m})$$

$F_{A1}$  : Support force at the rudder horn lower-support, in N, to be obtained according to **Fig 4.1.7** of the Guidance, and taken equal to  $B_1$ .

$F_{A2}$  : Support force at the rudder horn upper-support, in N, to be obtained according to **Fig 4.1.7** of the Guidance, and taken equal to  $B_2$ .

$z$  : Distance, in m, defined in **Fig 4.1.8** of the Guidance, to be taken less than the distance  $d$ , in m, defined in the same figure.

$d_{lu}$  : Distance, in m, between the rudder-horn lower and upper bearings (according to **Fig 4.1.7** of the Guidance)

$$d_{lu} = d - \lambda$$

(4) Rudder horn shear force

The shear force  $Q_H$  acting on the generic section of the rudder horn is to be obtained from the following formulae:

between the lower and upper rudder horn bearings:

$$Q_H = F_{A1} \quad (\text{N})$$

above the rudder horn upper-bearing:

$$Q_H = F_{A1} + F_{A2} \quad (\text{N})$$

$F_{A1}$  and  $F_{A2}$  : Support forces (N)

The torque  $M_T$  acting on the generic section of the rudder horn is to be obtained from the following formulae:

between the lower and upper rudder horn bearings:

$$M_T = F_{A1} e(z) \quad (\text{N-m})$$

above the rudder horn upper-bearing:

$$M_T = F_{A1} e(z) + F_{A2} e(z) \quad (\text{N-m})$$

$F_{A1}$  and  $F_{A2}$  : Support forces (N)

$e(z)$  : Torsion lever, in m, defined in **Fig 4.1.8** of the Guidance.

(5) Rudder horn shear stress calculation

The shear stress acting on the generic section of the rudder horn is to be obtained from the following formulae:

between the lower and upper rudder horn bearings:

$$\tau_S = \frac{F_{A1}}{A_H} \quad (\text{N/mm}^2)$$

above the rudder horn upper-bearing:

$$\tau_S = \frac{F_{A1} + F_{A2}}{A_H} \quad (\text{N/mm}^2)$$

$F_{A1}$  and  $F_{A2}$  : Support forces (N)

$A_H$  : Effective shear sectional area of the rudder horn in y-direction ( $\text{mm}^2$ )

The torsional stress to be obtained for hollow rudder horn from the following formula. For solid rudder horn, the torsional stress is to be considered by the Society on a case by case basis.

$$\tau_T = \frac{M_T 10^{-3}}{2F_T t_H} \quad (\text{N/mm}^2) \quad (2019)$$

$M_T$  : Torque (N-m)

$F_T$  : Mean of areas enclosed by outer and inner boundaries of the thin walled section of rudder horn ( $\text{m}^2$ )

$t_H$  : Plate thickness of rudder horn (mm). For a given cross section of the rudder horn, the maximum value of  $\tau_T$  is obtained at the minimum value of  $t_H$ .

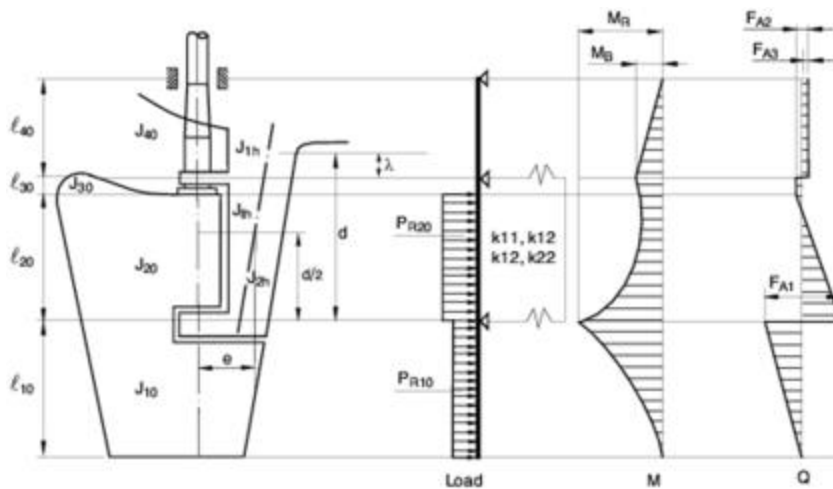
(6) Rudder horn bending stress calculation

For the generic section of the rudder horn within the length  $d$  defined in **Fig 4.1.8** of the Guidance, the following bending stresses are to be calculated:

$$\sigma_B = \frac{M_H}{Z_x} \quad (\text{N/mm}^2)$$

$M_H$  : Bending moment at the section considered (N-m)

$F_T$  : Section modulus around the  $x$ -axis ( $\text{cm}^3$ )



**Fig 4.1.7 Type E rudders**  
(Semi spade rudder with 2-conjugate elastic support)

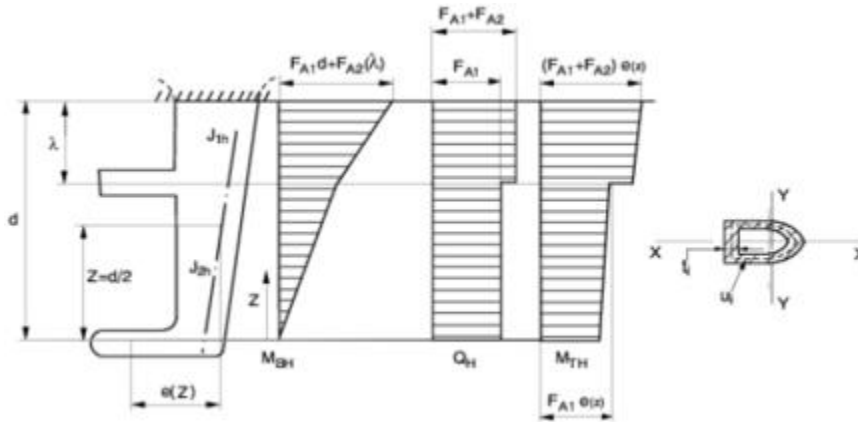


Fig 4.1.8 Rudder horn

## Section 5 Rudder Stocks

### 501. Upper stocks [See Rule]

#### 1. Taper of upper stock at joint with tiller

Where the upper stocks are tapered for fitting the tiller, the taper is not to exceed 1/12.5 in diameter.

#### 2. Keyways

- (1) The depth of the keyway may be neglected in determining the diameter of the rudder stock.
- (2) All corners of keyways are to be properly rounded.

#### 3. Each part of the rudder stocks of Type B, C and D rudders is to be so constructed as shown Fig 4.1.9 of the Guidance.

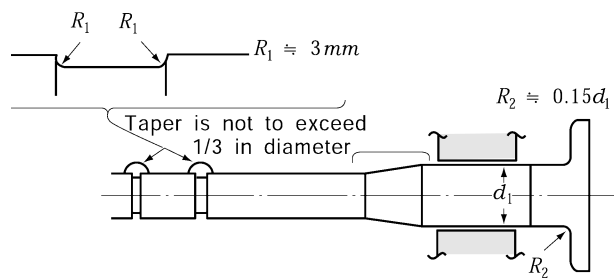


Fig 4.1.9 Rudder stock of type B, C and D rudder

### 503. Deformations

Before significant reductions in rudder stock diameter due to the application of steels with yield stresses exceeding 235 (N/mm<sup>2</sup>) are granted, the Society may require the evaluation of the rudder stock deformations. Large deformations of the rudder stock are to be avoided in order to avoid excessive edge pressures in way of bearings.

## Section 6 Rudder Plates, Rudder Frames and Rudder Main Pieces

### 603. Rudder main pieces [See Rule]

1. In Type *D* and Type *E* rudders, the effective breadth of rudder plate  $B_e$  to be as shown in **Fig 4.1.10** of the Guidance. However, the cover plate which is removed to lift up the rudder is not to be included into the section modulus. These requirements also apply to Type *A* rudders correspondingly.
2. Material factor  $K_m$  is to be for the lowest strength material among the materials used in the section considered.

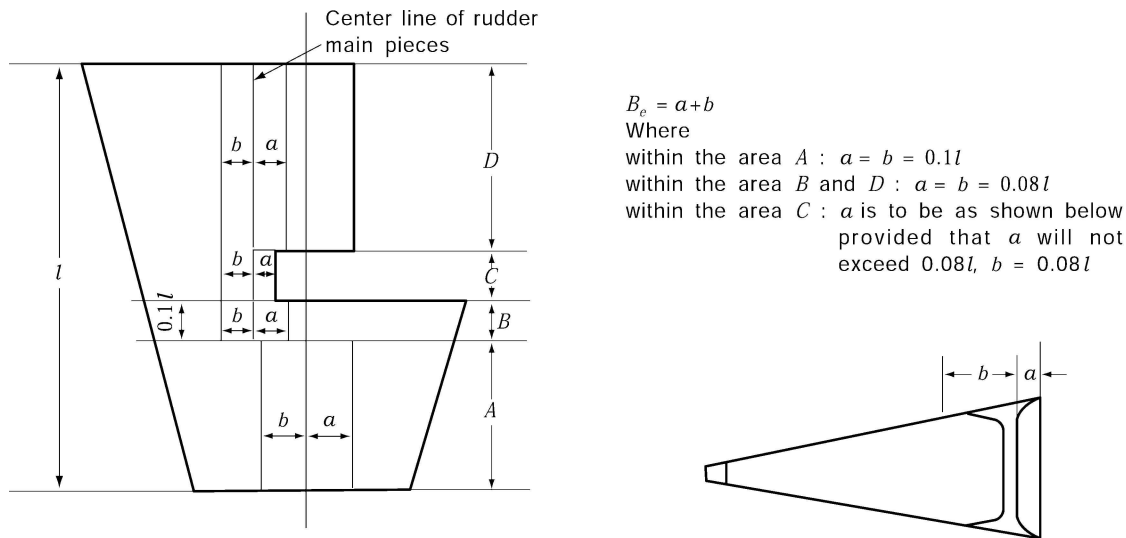


Fig 4.1.10 Effective breadth of rudder plate  $B_e$

### 605. Connections [See Rule]

In principle, edge bars are to be fitted to the aft end of the rudder. However, considering the size and form of the rudder, weld ability, etc., edge bars and or chill plates may be omitted. (See **Fig 4.1.11** of the Guidance)

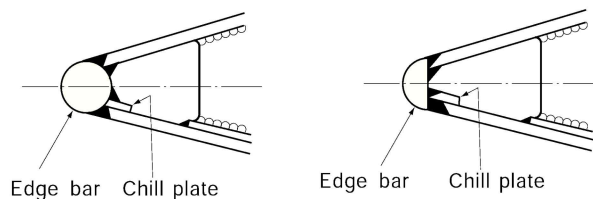


Fig 4.1.11 Structure of end part of rudder

## Section 7 Couplings between Rudder Stocks and Main Pieces

### 701. Horizontal flange coupling [See Rule]

#### 1. Diameters of coupling bolts in Type *A* and Type *E* rudders

In applying to Pt 4, Ch 1, 701. of the Rules, the diameters of coupling bolts  $d_b$  in Type *A* and Type *E* rudders are to be determined in accordance with the requirements in Pt 4, Ch 1, 502. of the Rules, assuming that the lower stock is cylindrical.

#### 2. Locking device for nuts of coupling bolts

The nuts of coupling bolts are to have locking devices. They may be split pins.

### 702. Vertical flange couplings [See Rule]

#### 1. Diameter of coupling bolt in Type *A* and *E* rudders

In applying to Pt 4, Ch 1, 701. of the Rules, the diameter of the coupling bolt  $d_b$  in Type *A* and *E* rudders are to be determined in accordance with Pt 4, Ch 1, 502. of the Rules, assuming that the lower stock is cylindrical.

#### 2. Locking devices for nuts of coupling bolts

The nuts of coupling bolts are to have locking devices. They may be split pins.

### 703. Cone coupling [See Rule]

#### 1. General

(1) The lower stock is to be securely connected to the rudder body with slugging nuts or hydraulic arrangements. Shipbuilders are to submit data on this connection to the Society.

(2) Special attention is to be paid to corrosion of the lower stock.

(3) The minimum thickness  $t_b$  is of the cast steel part of rudder body (See Fig 4.1.12 of the Guidance) not to be less than 0.25 times the required diameter of the lower stock.

2. Keys provided on the cone coupling for rudder stocks fitted into the rudder body and secured by a nut (Cone couplings without hydraulic arrangements for mounting and dismounting the coupling), where the entire rudder torque is transmitted by the key at the couplings as described in 703. 1 (8) of the Rules, the following requirements are to be complied with:

(1) The shear area  $A_k$  of keys is not to be less than:

$$A_k = \frac{30 T_R K_k}{d_k} \quad (\text{mm}^2)$$

$d_k$  = rudder stock diameter at the mid-point of length of the key (mm)

$K_k$  = material factor for the key as given in Pt 4, Ch 1, 103. of the Rules

$T_R$  = rudder torque obtained from Pt 4, Ch 1, Sec 3 of the Rules

(2) The abutting surface area  $A_c$  between key and rudder stock or between key and rudder body, respectively, is not be less than:

$$A_c = \frac{10 T_R K_{\min}}{d_k} \quad (\text{mm}^2)$$

where:

$K_{\min}$  = material factor for key, rudder stock, or rudder body as given in Pt 4, Ch 1, 103. of the Rules, whichever is smaller in comparison between the factors for key and rudder stock, and for key and rudder body in contact.

$d_k$  and  $T_R$  = as specified in (1).

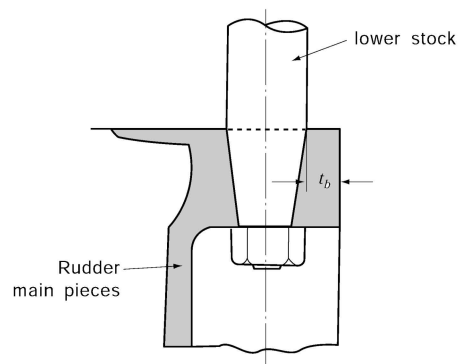


Fig 4.1.12 Coupling between rudder lower stock and rudder main pieces

## Section 8 Pintles

### 802. Construction of pintles [See Rule]

#### 1. Locking device for pintle nut

Split pins are not recommendable as the locking device for the pintle nuts. Locking rings or other equivalent devices (Nut stopper or Nut lock, etc.) are to be used, as shown in Fig 4.1.13 of the Guidance.

#### 2. Preventing corrosion of pintles

To prevent corrosion of pintles, the end of the sleeve is to be filled with red lead, grease packing, bituminous enamel, rubber (Neoprene) etc., as shown in Fig 4.1.13 of the Guidance.

#### 3. Combination of pintle and rudder frame in monoblock

In ships exceeding 80 m in length, combination of pintle and rudder frame into a monoblock is not recommended.

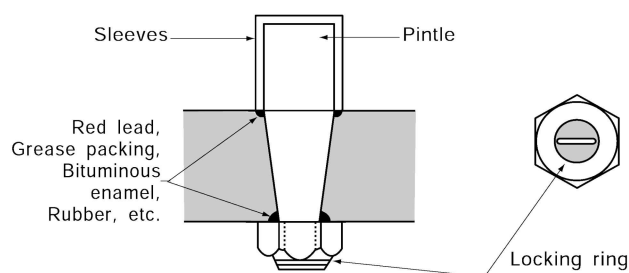


Fig 4.1.13 Locking device and preventing device of corrosion of pintle nut

## Section 9 Bearings of Rudders Stock and Pintles

### 901. Minimum bearing surface [See Rule]

Where a metal bush is used, the sleeve is to be a different material from the bush (for example, sleeve :  $BC_3$  and bush :  $BC_2$ ).

### 903. Bearing clearances [See Rule]

Where a bush is non-metal, the standard bearing clearances is to be 1.5 ~ 2.0 mm in diameter.

## Section 10 Rudder Accessories

### 1001. Rudder carriers [See Rule]

#### 1. Materials of rudder carriers and intermediate bearings

Rudder carriers and intermediate bearings are to be of steel. They are not to be of cast iron.

#### 2. Thrust bearing of rudder carrier

- (1) The bearing is to be provided with a bearing disc made of bronze or other equivalent materials.
- (2) The calculated bearing pressure is not to exceed 0.98 MPa (0.1 kg/mm<sup>2</sup>) as a standard. In calculating the weight of rudder, its buoyancy is to be neglected.
- (3) The bearing part is to be well lubricated by dripping oil, automatic grease feeding, or a similar method.
- (4) The bearing is to be designed to be structurally below the level of lubricating oil at all times. (See **Fig 4.1.14** of the Guidance)

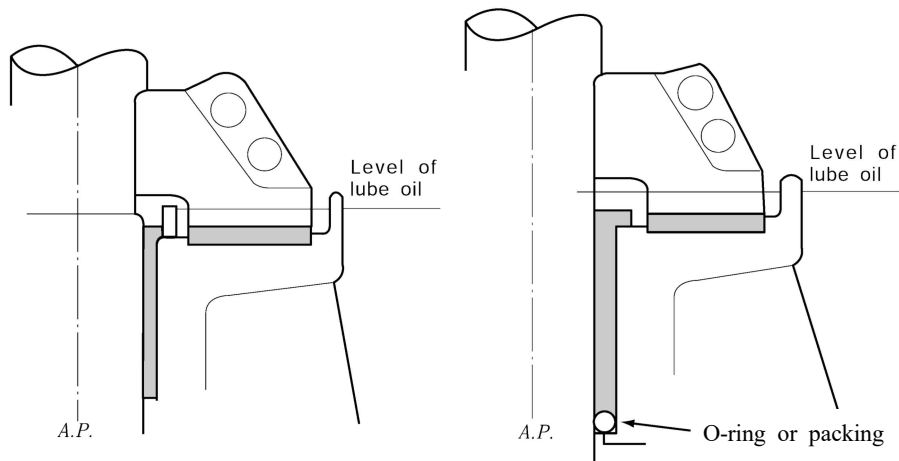


Fig 4.1.14 Rudder carrier

#### 3. Watertightness of rudder carrier part

- (1) In rudder trunks which are open to the sea, a seal or stuffing box is to be fitted above the deepest load waterline to prevent water from entering the steering gear compartment and the lubricant from being washed away from the rudder carrier. If the top of the rudder trunk is below the deepest waterline two separate stuffing boxes are to be provided.
- (2) It is recommended that the packing gland in the stuffing box have an appropriate clearance from the rudder stock corresponding to the position of the stuffing box. The standard clearance is to be 4 mm for the stuffing box provided at the neck or intermediate bearing, and 2 mm for the stuffing box at the upper stock bearing.

#### 4. Assembling of rudder carriers

In split type rudder carriers, at least two bolts are to be used on each side of the rudder for assembling.

#### 5. Installation of rudder carriers

- (1) In ships exceeding 80 m in length, it is recommended that the rudder carrier is directly installed on the seat on a deck.
- (2) A spigot type seat is not recommended to be installed on the deck.
- (3) The hull construction in way of the rudder carrier is to be suitably reinforced.

#### 6. Bolts fixing rudder carriers and intermediate bearing

- (1) As a standard, at least one half of the bolts fixing the rudder carrier and the intermediate bearing are to be reamer bolts. If stoppers for preventing the rudder carrier from moving are to be fitted on the deck, all bolts may be of ordinary bolts. In using chocks as stoppers, all of them are to be carefully arranged not to be driven in the same direction. (See **Fig 4.1.15** of the

Guidance)

- (2) (A) In ships provided with electro hydraulic steering gears, the total sectional area of the bolts fixing the rudder carriers or the bearing just under the tiller to the deck is not to be less than that obtained from the following formula:

$$A = 0.1d_u^2 \quad (\text{mm}^2)$$

$d_u$  = required diameter of upper stock(mm)

- (B) Where the arrangement of steering gear is such that each of two filler arms is connected with an actuator and two actuators function simultaneously, or is of any other type where the rudder stock is free from horizontal force, the total sectional area of bolts fixing the rudder carrier to the deck may be reduced to 60 % of the area required in (A).  
(C) Where all the bolts fixing the rudder carrier to the deck are reamer bolts, the total sectional area of bolts may be reduced to 80 % of the area required by (A) and (B).

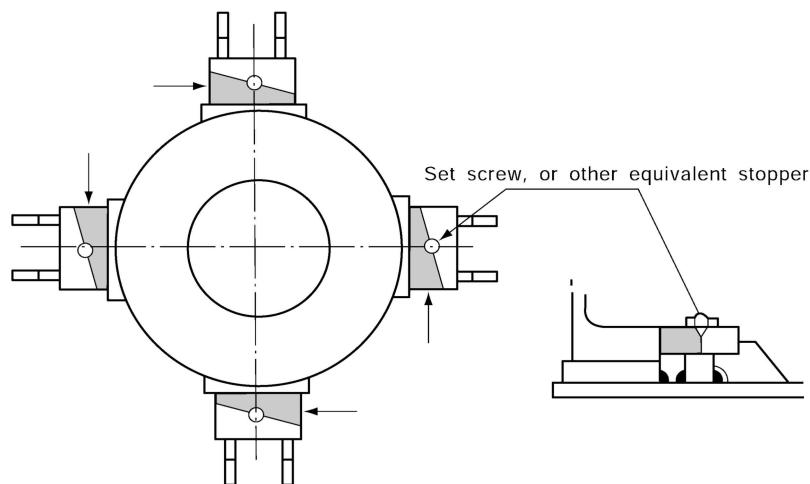


Fig 4.1.15 Fixing arrangement of rudder carrier on deck

#### 1002. Jumping stoppers [See Rule]

The clearance between the jumping stopper and the rudder carrier is to be 2 mm as a standard.

### Section 11 Propeller Nozzles

#### 1101. Application [See Rule]

In 1101. 1 of the Rules, the term "specially considered" means the cases as considered in accordance with Pt 1, Ch 1, 104. or 105. of the Guidance. ⚓

## CHAPTER 2 HATCHWAYS AND OTHER DECK OPENINGS

### Section 1 General

#### 101. Application [See Rule]

The regulation of **101. 2** of the Rules is not to be applied to the vessel which engaged in domestic service only.

#### 102. Position of exposed deck openings (2017) [See Rule]

In application of **102.** of the Rules, the details are as follows.

Position 1 - Upon freeboard decks and raised quarterdecks, or other exposed decks\* lower than one standard height of superstructure above the freeboard deck, and upon exposed decks\* situated forward of a point located a quarter of the ship's length from the forward perpendicular that are located lower than two standard heights of superstructure above the freeboard deck.

Position 2 - Upon exposed decks\* situated abaft a quarter of the ship's length from the forward perpendicular and located at least one standard height of superstructure above the freeboard deck and lower than two standard heights of superstructure above the freeboard deck.

- Upon exposed decks\* situated forward of a point located a quarter of the ship's length from the forward perpendicular and located at least two standard heights of superstructure above the freeboard deck and lower than three standard heights of superstructure above the freeboard deck.

\* "Exposed decks" include top decks of superstructures, deckhouses, companionways and other similar deck structures.

#### 104. Hatch covers [See Rule]

1. Steel hatch covers in way of tanks loading cargo oil of flash point below 60 °C are to be paid enough attention in order to keep oil-tightness and air-tightness and to prevent occurring sparks due to striking of the surrounding metal fittings. And their gaskets are to be of materials certified as oilproof and fireproof by the relative standard.

2. In principle, double plating hatch covers are not to be used in way of oil tanks. However, if they are to be used, their construction is to be easily drained out and vented by air.

3. In **104. 2** of the Rules, the term "the discretion of the society" means that the hatch cover comply with below requirements. In this article sand carrier and dredger mean that the ships are engaged in gathering, transporting, dredging or reclamation etc. for sand, soil, gravel etc.

(1) For the ship which operates in domestic-costal service area, the requirement for exemption of hatchway covers of sand carrier and dredger is as follows.

(A) Barge and self-propelled ship having hopper door (2018)

Barge and self-propelled ship which is fitted with a buoyancy tank in each side and hopper door in bottom should have sufficient reserved buoyancy and stability in assumed the worst flooded condition of cargo hold.

(B) Barge not having a hopper door (2017)

Barges which have buoyancy tanks of sufficient capacity for both sides and are considered to have sufficient reserve buoyancy and stability even in assumed worst flooded condition of the cargo hold. However, barges intend to sail to Jeju Island are to have hatch covers.

(C) For the exemption of hatchway cover installation, it should be met with the following conditions in assumed the worst flooded condition.

(a) The upper deck side line should be not flooded

(b) For self-propelled ship :  $G_0M \geq 0.15$  m

For non self-propelled ship :  $G_0M \geq 0.095B$  m

(where,  $B$  = Breadth)

(2) For the ship which operates in international service area and is fitted with door or valve in bot-

tom, the requirement for exemption of hatchway cover installation of sand carrier and dredger is as follows.

- (A) The intact stability is to be met with the requirement of **Pt 1, Annex 1-2** of the Guidance. In this case, the calculation is to include the homogeneous full load condition of cargo in each cargo hold loaded up to the top of the hatchway coaming.
- (B) When the wetted cargo with the design bulk density of minimum  $2.2 \text{ ton/m}^3$  is homogeneously loaded to the assigned freeboard in each hold and assuming that the void space of the cargo hold above the cargo surface is filled with the sea water induced by the flooding, the stability of the above (A) is to be satisfied.
- (C) The damage stability is to be met with **SOLAS Ch. II-1, B-1**
- (D) The doors or valves on bottom area are to be met with following requirements.
  - (a) The opening of the bottom dump doors should be effective in less than one(1) minute.
  - (b) In the case of bottom door not to be opened by gravity, the opening should be possible even after the main power source or the ram mechanism actuating the bottom dump doors have been put out of order.  
In this case, it should be possible to operate both systems from bridge, and the cargo releasing arrangements should be such that asymmetrical jettisoning of the cargo should not be possible even partially.
- (E) Draft indicator is to be fitted on the bridge.
- (F) Where the additional requirements other than described above are necessary, the ship is to be met with those requirements also.

#### **107. Corrosion additions [See Rule]**

In **107. 3. (3)** of the Rules, the term "when this is deemed necessary, at the discretion of the individual class society's surveyor" means the acceptance in accordance with **Pt 1, Ch 1, 801. 3** of the Guidance.

#### **108. Operation and maintenance manual for hatch cover**

It is recommended that ships with steel weathertight covers are supplied with an operation and maintenance manual including following (1) to (5)

- (1) Opening and closing instructions
- (2) Maintenance requirement for packings, securing devices and operating items,
- (3) Cleaning instruction for drainage system
- (4) Corrosion prevention instructions.
- (5) Lists of spare parts.

## **Section 2 Design Load**

#### **204. Cargo load**

When the cargoes loaded on hatch covers of exposed parts and lower deck, the loading height, loading condition, etc, is to be clearly shown in the drawings for approval. In case of loading freight containers, the kind of them and loading position are to be additionally described.

## **Section 3 Hatch cover strength criteria**

#### **303. Net plate thickness of hatch cover**

- 1. In **303. 3 (4)** of the Rules, the term "should be determined according to the Society" means the case where the lower plating not be less than 2.0 mm. **[See Rule]**
- 2. In **303. 4** of the Rules, the term "have to be derived from the Society" means to comply with **Pt 7, Ch 3, 301.** of the Guidance. **[See Rule]**

---

---

## **Section 5 Hatch cover details – Closing Arrangement, Securing Devices and Stoppers**

### **502. General [See Rule]**

In **502. 6** of the Rules, the term "considered by the Society" means the cases as considered in accordance with **Pt 1, Ch 1, 104.** or **105.** of the Guidance.

## **Section 7 Miscellaneous Openings**

### **702. Companionways [See Guidance]**

#### **1. Grouping into deckhouse and companionway**

- (1) A structure is regarded as a deckhouse where its inside is always accessible through access openings provided on the top of the structure or through under-deck passageways, even when all access openings in the boundary walls are closed
- (2) A structure is regarded as a companionway where its inside is not accessible through any other way, when all access openings in the boundary walls are closed. ↓

## CHAPTER 3 BOW DOORS, SIDE AND STERN DOORS

### Section 1 Bow Doors and Inner Doors

#### 101. General

##### 1. Application

- (1) The following measures are to be complied with by all existing ro-ro passenger ships with the date of building before or on the 30th June 1996, including, when not differently deliberated by the competent flag Administrations, ships only engaged on domestic sea voyages.
  - (A) The structural condition of bow doors and inner doors, especially the primary structure, the securing and supporting arrangements and the hull structure alongside and above the doors, are to be specially examined and any defects rectified.
  - (B) The operating procedures of the bow door and inner door are to comply with the requirements of **Pt 4, Ch 3, 108.** of the Rules.
  - (C) The location and arrangement of inner doors are to comply with the applicable requirements of the **SOLAS** Convention and with **Pt 4, Ch 3, 101. 3. (3)** of the Rules.
  - (D) Ships with visor door are to comply with **Pt 4, Ch 3, 106. 2. (7)** of the Rules. requiring redundant provision of securing devices preventing the upward opening of the bow door. In addition, where the visor door is not self closing under external loads (i. e. the closing moment  $M_y$  calculated in accordance with **Pt 4, Ch 3, 103. 1. (3) (A)** of the Rules is less than zero) then the opening moment  $M_0$  is not to be taken less than  $-M_y$ . If drainage arrangements in the space between the inner and bow doors are not fitted, the value of  $M_0$  is to be specially considered. Where available space above the tanktop does not enable the full application of **Pt 4, Ch 3, 106. 2. (7)** of the Rules, equivalent measures are to be taken to ensure that the door has positive means for being kept closed during seagoing operation.
  - (E) For visor doors, the securing and supporting device excluding the hinges to be capable of bearing the vertical design force ( $F_z - 10W$ ), in kN, within the permissible stresses given in **Table 4.3.1** of the Rules.
  - (F) For side-opening doors, the structural arrangements for supporting vertical loads, including securing devices, supporting devices and, where applicable, hull structure above the door, are to be re-assessed in accordance with the applicable requirements of **Pt 4, Ch 3, 106.** of the Rules and modified accordingly.
  - (G) The securing and locking arrangements for bow doors and inner doors which may lead to the flooding of a special category space or Ro-Ro cargo space as defined in the **Pt 4, Ch 3, 101. 4** of the Rules, are to comply with the following requirements: **[See Rule]**
    - (a) Separate indicator lights and audible alarms are to be provided on the navigation bridge and on each operating panel to indicate that the doors are closed and that their securing and locking devices are properly positioned. The indication panel is to be provided with a lamp test function. It shall not be possible to turn off the indicator light.
    - (b) The indication panel on the navigation bridge is to be equipped with a mode selection function harbour / sea voyage, so arranged that audible alarm is given if the vessel leaves harbour with side shell or stern doors not closed or with any of the securing devices not in the correct position.
    - (c) A water leakage detection system with audible alarm and television surveillance is to be arranged to provide an indication to the navigation bridge and to the engine control room of any leakage through the doors.

## Section 2 Side Shell Doors and Stern Doors

### 201. General

#### 1. Application

- (1) The following measures are to be complied with by all existing ro-ro passenger ships with the date of building before or on the 30th June 1997, including, when not differently deliberated by the competent flag Administrations, ships only engaged on domestic sea voyages.
  - (A) The structural condition of side shell doors and stern doors, especially the primary structure, the securing and supporting arrangements and the hull structure alongside and above the doors, are to be specially examined and any defects rectified.
  - (B) The structural arrangement of securing devices and supporting devices of inwards opening doors in way of these securing devices and, where applicable, of the surrounding hull structure is to be reassessed in accordance with the applicable requirements of **Pt 4, Ch 3, 205.** of the Rules and modified accordingly.
  - (C) The securing and locking arrangements for side and stern doors which may lead to the flooding of a special category space or Ro-Ro cargo space as defined in the **Pt 4, Ch 3, 101. 4** of the Rules, are to comply with the following requirements: **[See Rule]**
    - (a) Separate indicator lights and audible alarms are to be provided on the navigation bridge and on each operating panel to indicate that the doors are closed and that their securing and locking devices are properly positioned. The indication panel is to be provided with a lamp test function. It shall not be possible to turn off the indicator light.
    - (b) The indication panel on the navigation bridge is to be equipped with a mode selection function harbour / sea voyage, so arranged that audible alarm is given if the vessel leaves harbour with side shell or stern doors not closed or with any of the securing devices not in the correct position.
    - (c) A water leakage detection system with audible alarm and television surveillance is to be arranged to provide an indication to the navigation bridge and to the engine control room of any leakage through the doors.
  - (D) Documented operating procedures for closing and securing side shell and stern doors are to be kept on board and posted at the appropriate places. ↓

# CHAPTER 4 BULWARKS, FREEING PORTS, SIDE SCUTTLES, RECTANGULAR WINDOWS, VENTILATORS AND PERMANENT GANGWAYS

## Section 1 Bulwarks and Guardrails

### 101. Arrangements [See Rule]

1. The term "where deemed necessary by that Society" means when the ship is recognized adequate protection is equipped, the height of bulkwark may be more than 600 mm and may be provided with stormrail on the wall which is located with 1 m height in deckhouse on upperdeck.
2. Nevertheless **101.** of the Rules, where the ships have undergone survey according to relevant governmental regulation and allowed to operate within costal area, the application of this requirement may be dispensed with.

### 106. Guardrails [See Rule]

1. At least every third stanchion shall be supported by a bracket or stay. In lieu of this, flat steel stanchions shall be of increased breadth as given in **Fig 4.4.1**, and aligned with member below deck unless the deck plating thickness exceeds 20 mm.

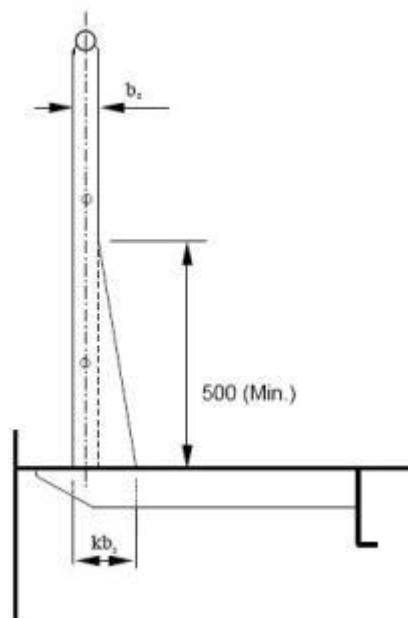


Fig 4.4.1 Guardrail stanchion of increased breadth

- (1) At least every third stanchion :  $kbs = 2.9 bs$
- (2) At least every second stanchion :  $kbs = 2.4 bs$
- (3) Every stanchion :  $kbs = 1.9 bs$

where,  $bs$  : breadth of normal stanchion according to the design standard.

2. Stanchions with increased breadth to be aligned with member below deck, min.  $100 \times 12$  flat bar. The member below deck are to be welded to deck by double continuous fillet weld with leg size of min. 7 mm or as specified by the design standard.
3. In application of **106. 3** of the Rules, wire ropes may only be accepted in lieu of guard rails in special circumstances and then only in limited lengths.

## Section 2 Freeing Ports

### 201. General [See Rule]

1. The adequate provision for freeing the spaces which are open at either or both ends within superstructure referred to in **Ch 4, 201. 3** of the Rules is subject to the (1) through (3).

- (1) The minimum freeing port area on each side of the ship for the open superstructure is not less than that obtained from the following formula.

$$A_s = \frac{A_1 b_0 h_s}{2 l_t h_w} \left\{ 1 - \left( \frac{l_w}{l_t} \right)^2 \right\} \quad (\text{m}^2)$$

Where,

$$A_1 = 0.7 + 0.035 l_t \quad (\text{m}^2) \quad l_t \text{ is not more than } 20 \text{ m}$$

$$= 0.07 l_t \quad (\text{m}^2) \quad l_t \text{ is more than } 20 \text{ m}$$

$$l_t : l_w + l_s \quad (\text{m})$$

$l_w$  : Where bulwark forms a well, the length of bulwark in well(m)

$l_s$  : Length of the common space within the open superstructure(m)

$b_0$  : Breadth of the openings in the end bulkhead of the enclosed superstructure(m)

$h_s$  : One standard superstructure height(m)

$h_w$  : The distance of the well deck above the freeboard deck(m)

- (2) The minimum freeing port area on each side of the ship for the open well is not less than that obtained from the following formula.

$$A_w = \frac{A_2 h_s}{2 h_w} \quad (\text{m}^2)$$

Where,

$$A_2 = 0.7 + 0.035 l_w + a \quad (\text{m}^2) \quad l_w \text{ is not more than } 20 \text{ m}$$

$$= 0.07 l_w + a \quad (\text{m}^2) \quad l_w \text{ is more than } 20 \text{ m}$$

$$a = 0.04 l_w (h - 1.2) \quad (\text{m}^2) \quad h \text{ is more than } 1.2 \text{ m}$$

$$= 0 \quad h \text{ is not more than } 1.2 \text{ m, but not less than } 0.9 \text{ m}$$

$$= -0.04 l_w (0.9 - h) \quad (\text{m}^2) \quad h \text{ is less than } 0.9 \text{ m}$$

$h$  : Average height of bulwark above the deck (m)

- (3) In ships either without sheer or with less sheer than the standard, the minimum freeing port area obtained from the above (1) and (2), is increased by multiply the factor obtained from **202. 2** of the Rules.

2. The requirements in **201. 4** of the Rules are applied to type A or B-100 ships with specially reduced freeboards.
3. The requirements in **202. 4** of the Rules are applied to type A or B-100 ships with specially reduced freeboard having trunks.

### 202. Freeing port area [See Rule]

1. A flush-decker having an effective deckhouse is to be considered to have two wells afore and abaft the deckhouse, and each of these wells is required to have freeing port area as prescribed in **202.** of the Rules. The term "effective deckhouse" means a structure having a breadth not less than 80 % of the breadth of ship and the width of passageways at its sides does not exceed 1.5 m.

2. Where a divisional bulkhead extending from side to side is provided at the forward end of deckhouse, the ship is to be considered to have two wells afore and abaft the bulkhead, irrespective of the breadth of deckhouse, and each of these wells is required to have the freeing port area as prescribed in **202.** of the Rules.
3. In ships which correspond to the requirements **201. 2** of the Rules, the guardrails installed at both sides for more than half of the length of the exposed parts of the freeboard deck, and in ships which correspond to the requirements in **201. 3** of the Rules, the guardrails installed at both sides for more than half of the length of trunks on the freeboard deck may be replaced by freeing ports of a total area not less than 33 % of the total area of bulwark in the lower parts of bulwarks.
4. In type B-60 ships, freeing ports in the lower parts of bulwarks are to have an area not less than 25 % of the total area of bulwark.
5. Where freeing ports are fitted with rails, etc., projected area of them is to be excluded from actual freeing port area in calculations.
6. Where set-in structure of side shell or superstructure from a well in pure car carrier, etc., adequate freeing ports are to be provided in accordance with the requirements of **202. 3** of the Rules.
7.
  - (1) The case where a ship is provided with a trunk or a hatch side coaming which is continuous or substantially continuous between detached superstructure specified in **202. 3** of the Rules means the case where  $F_0$  is equal to, or less than  $F_1$ , where  $F_0$  and  $F_1$  are shown in the following.

$F_0$  : Free flow area through which water runs across the deck given by the following formula(m<sup>2</sup>)

$$\Sigma(l_i h_i - a_i)$$

Where,

$l_i$  : Distance between hatchways, and between hatchways and superstructures and deckhouse(m)

$h_i$  : Height of bulwarks(m)

$a_i$  : Projected area of structure which prevent free flow in  $l_i \cdot h_i$ .

$F_1$  : As specified in **202. 1** and **2** of the Rules.(m<sup>2</sup>)

- (2) Where  $F_0$  is greater than  $F_1$ , but not greater than  $F_2$ , freeing port area ( $F$ ) is increased by the following formula with the value obtained from **202. 1** and **2** of the Rules.  
 $F_0$  and  $F_1$  are shown in the above (1),  $F_2$  is specified in **202. 3** of the Rules.

$$F = F_1 + F_2 - F_0 \text{ (m}^2\text{)}$$

- (3) Where  $F_0$  is greater than  $F_2$ ,  $F$  is equal to  $F_1$ .

8. Nevertheless **101. 1** thou. **3** of the Rules, where the ships operate within costal area which the ship could go and return from smooth water within 2 hours by the maximum speed, the freeing port area could be deducted to the half area of the required freeing port area.
9. For ships designed to carry cargo only on the deck, where coamings or other structures for retaining deck cargo form wells, adequate freeing ports are to be provided in accordance with **Ch 18, 301.** of Guidance for Steel Barges. (2019)

### 203. Arrangement of freeing ports [See Rule]

1. In ships having very small shear or without shear, the area of freeing ports is to be distributed throughout the whole length of the well.

2. Specially, for the ships having reduces freeboard, freeing ports having not less than 25 % of total area of bulwarks is to be provided in lower part of bulwarks.

**204. Structure [See Rule]**

In case fishing vessels etc. which are accepted to this Society are fitted securing and locking devices, its structure are to be of an approved one.

### **Section 3 Side Scuttles, Rectangular Windows and Skylights**

**301. General Application [See Rule]**

1. With respect to the provisions of **Ch 4, 301.** of the Rules, the term as deemed as appropriate by the Society means that the side scuttles and rectangular windows is to be in conformity corresponding to the position and to have appropriate weathertightness.
2. With respect to the provisions of **Ch 4, 301.** and **302.** of the Rules, windows on a navigation bridge within the third tiers above the freeboard deck, which is granted to be of rectangular window in accordance with the provisions of **306.** of the rules, may be of rectangular window other than of class E or F subject to the following (1) and (2)
  - (1) The navigation bridge is to be separated from spaces below the freeboard deck and spaces within superstructures by the following
    - (A) Weathertightness closing devices
    - (B) Two or more cabin bulkheads or doors. In such case, the height of sills of the doorway to the navigation bridge are not to be less than those required for closing devices at the position of such doorway.
  - (2) The design pressure of such windows is not to be less than the value specified in **308.** of the Rules and construction of frames, etc. for such windows is to be in conformity to those required for the class E, F rectangular window corresponding to the position of such windows and to have appropriate weathertightness.

**303. Application of side scuttle [See Rule]**

1. The wording as deemed as appropriate by the Society in **303. 5** of the Rules means that the side scuttles may be class A or class B side scuttles without deadlight.
2. Nevertheless **303. 1** thou. **9** of the Rules, the side scuttles of the ship which operates in the costal and smooth water service could be accepted as the followings
  - (1) The side scuttles of the ship which operates in the costal service to be in accordance with **Table 4.4.1** or equivalent thereto.
  - (2) The side scuttles of the ship which operates in the smooth water service to be in accordance with **Table 4.4.2** or equivalent thereto.
  - (3) The side scuttles of the superstructures and deckhouses above main deck not to be installed below seal height of the superstructures and deckhouses. However, where it is not practicable, the side scuttles with deadlight could be accepted.

Table 4.4.1 The side scuttles of the ship which operates in the costal service

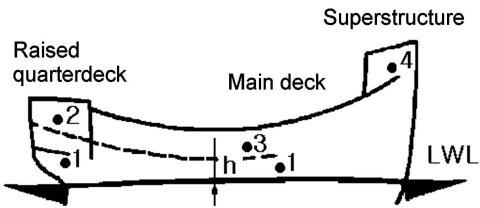
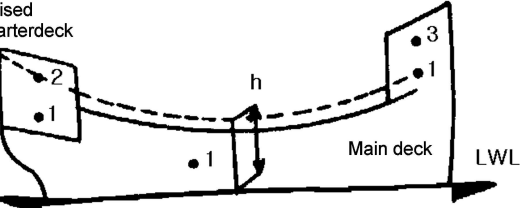
Location of installation	Requirements
<p>(1)</p>  <p><math>h = 0.025B</math> or 500mm, whichever is the greatest distance --- is parallel to the main deck</p>	<ul style="list-style-type: none"> <li>○ 1 Side scuttle impermissible</li> <li>○ 2 Type A, however, type B with deadlight could be accepted in the ship which operates in the registered costal service.</li> <li>○ 3 Type A</li> <li>○ 4 Type B, however, type C could be accepted in the ship which operates in the registered costal service.</li> </ul>
<p>(2)</p>  <p><math>h</math> and --- = same as (1)</p>	<ul style="list-style-type: none"> <li>○ 1 Side scuttle impermissible</li> <li>○ 2 Type A</li> <li>○ 3 Type A, however, type C with deadlight could be accepted in the ship which operates in the registered costal service.</li> </ul>
<p>(3) Below <math>h</math> dot line as deck house above main deck of (2)</p>	<p>Side scuttle impermissible</p>
<p>(4) Machinery space casings or companionway casings on the main deck or exposed superstructure deck</p>	<p>Type B with deadlight, however, type C with deadlight could be accepted in the ship which operates in the registered costal service.</p>
<p>(5) End bulkheads of superstructure having companionway on the main deck inside space (except the exposed companionway whose protect device is in accordance with the closure requirements of companionways). However, end and side bulkheads given in (3), (7) and (8) to be excepted.</p>	<p>Type C with deadlight</p>
<p>(6) Fore end bulkheads of deck house having companionway on the main deck inside space (except the exposed companionway whose protect device is in accordance with the closure requirements of companionways).</p>	<p>Type C with deadlight</p>
<p>(7) Side and aft end bulkheads of superstructure having door sill height installed on end bulkhead which is more than 230 mm and door attached on that bulkhead which is strong enough and could be closed securely inside and outside whose companionway on the main deck is arranged around 0.6 m or over from end and side bulkheads and whose companionway coaming height is not less than 150 mm (except side bulkheads of forecastle between fore end and 0.07 L point from fore end).</p>	<p>Type C</p>
<p>(8) Side and aft end bulkheads of Superstructures having companionway on the main deck inside space whose companionway is arranged around 0.6 m or over from end and side bulkheads and whose companionway coaming height is not less than 230 mm.</p>	<p>Type C</p>

Table 4.4.1 The side scuttles of the ship which operates in the costal service (continued)

Location of installation	Requirements
(9) Side and aft end bulkheads of deck house on the main deck having companionway on the main deck inside space (except the exposed companionway whose protect device is in accordance with the closure requirements of companionways).	Type C, however, rectangular window could be accepted in the ship which operates in the registered costal service. In this case, the thickness of glass holder is to be not less than 2.0 mm and those materials to be made of light alloy. The thickness of glass (only the reinforced glass) for side scuttles is to be not less than the following.  $t = \sqrt{\frac{p \cdot \beta \cdot b^2}{40,000}}$ where, <i>t</i> : Glass thickness (mm) <i>p</i> : As specified in <b>Ch 4, 305.</b> of the Rules <i>β</i> : As specified in <b>Ch 8, Fig 4.8.8</b> of the Rules <i>b</i> : minor dimension of the window (mm)
(10) End and side bulkheads of superstructures or deck houses not specified in (3) and (5) thou. (9).	Equivalent strength of the requirement in (9) and weathertightness according to the location of attachment to be secured.
(Note) 1. "Registered costal" means smooth water and costal area which the ship could go and return from smooth water within 2 hours by the maximum speed.	

Table 4.4.2 The side scuttles of the ship which operates in the smooth water

Location of attachment	Requirements
(1) Below a line drawn parallel to the main deck at side and having its lowest point 0.025B or 500mm, whichever is the greatest distance, above the Load Line.	Side scuttle impermissible
(2) Space below the main deck not specified in (1)	Type B
(3) Space not specified in (1) and (2)	Equivalent strength of the requirement in <b>Table 4.4.1 (10)</b> and weathertightness according to the location of attachment to be secured.

**305. Design pressure and maximum allowable pressure of side scuttle. [See Rule]**

With respect to provisions of **305. 1** of the Rules, the value of coefficient "a" for the side scuttles for spaces below the freeboard deck or spaces within the superstructures may be determined in applying the provisions of **Pt 3, Ch 17, 201.** of the Rules as the first tier deckhouse.

**307. Application of rectangular window [See Rule]**

The wording as deemed as appropriate by the Society in **307. 3** of the Rules means that the rectangular windows may be rectangular windows without shutter or deadlight.

## Section 4 Ventilators

### 402. Height of coamings [See Rule]

Ventilating systems for the machinery spaces to be in accordance with **Pt 5, Ch 1, 108. 2** of the Rules in addition to the requirement of **402.** of the Rules.

### 403. Thickness of coamings [See Rule]

In application to **403. 2, Table 4.4.6** of the Rules, the term "to be in accordance with the discretion of the Society" means the cases where the coaming thickness not be less than 8.5mm.

## Section 5 Permanent Gangways

### 501. General [See Rule]

1. Protection of crew provided in exposed freeboard deck, superstructure deck, crew accommodation area and machinery space and other area locations in question is to be in accordance with **Table 4.4.3.**
2. Where the access way(gangway, walkway may be included in access way) is provided, it is to be complied with the followings.
  - (1) Wire rope may only be accepted in lieu of guard rails in special circumstances and then only in limited length.
  - (2) In all cases where wire ropes are fitted, adequate devices are to be provided to ensure their tautness.
  - (3) Lengths of chain may only be accepted in lieu of guard rails if fitted between two fixed stanchions.
  - (4) Where stanchions are fitted, every 3rd stanchion is to be supported by a bracket or stay.
  - (5) Removable or hinged stanchions shall be capable of being locked in the upright position.
  - (6) A means of passage over obstructions. if any, such as pipes or other fittings of permanent nature should be provided.
  - (7) Generally, the width of gangway or deck-level walkway should not exceed 1.5 m.
3. For oil tankers, chemical tankers and gas carriers constructed before 1st July 1998, existing arrangements which complied with (b) or (c) may be accepted in lieu of (e) or (f) provided such existing arrangements are fitted with shelters and means of access to and from the deck as required for the arrangements (e) or (f) as defined in **Table 4.4.3.**
4. For tankers less than 100 m in length ( $L_f$ ), the minimum width of the gangway platform or deck level walkway fitted in accordance with arrangements (e) or (f), respectively, may be reduced to 0.6 m. ↓

Table 4.4.3 Protection of crew

Type of ships	Location of access in ship	Assigned summer freeboard	Acceptable arrangements according to type of freeboard assigned:				
			Type A	Type B-100	Type B-60	Type B&B+	
Other than tankers(Oil tankers, chemical tankers and gas carriers)	1. Access to Mid ship quarters. (1) Between poop and bridge, or (2) Between poop and deckhouse containing living accommodation or navigating equipments, or both	≤ 3000 mm	a b e	a b e	a b c(1) e f(1)	a b c(1) c(2) c(4) d(1) d(2) d(3) e f(1) f(2) f(4)	
		> 3000 mm	a b e	a b e	a b c(1) c(2) e f(1) f(2)		
	2. Access to end. (1) Between poop and bow(if there is no bridge), (2) Between bridge and bow, or (3) Between a deckhouse containing living accommodation or navigating equipments, or both, and bow, or (4) In the case of a flush deck vessel, between crew accommodation and the forward and after ends of ship	≤ 3000 mm	a b c(1) e f(1)	a b c(1) c(2) e f(1) f(2)	a b c(1) c(2) e f(1) f(2)		
		> 3000 mm	a b c(1) d(1) e f(1)	a b c(1) c(2) d(1) d(2) e f(1) f(2)	a b c(1) c(2) c(4) d(1) d(2) d(3) e f(1) f(2) f(4)		
	Tankers (Oil Tankers, Chemical Tankers and Gas Carriers)	1. Access to Bow (1) Between poop and bow, or (2) Between a deckhouse containing living accommodation or navigating equipment, or both, and bow, or (3) In the case of a flush deck vessel, between crew accommodation and the forward ends of ship	≤ ( $A_f^* + H_s^{**}$ )				a e f(1) f(5)
			> ( $A_f^* + H_s^{**}$ )				a e f(1) f(2)
2. Access to after end In the case of a flush deck vessel, between crew accommodation and the after ends of ship					as required in 2. (4) for other type of vessels.		

Table 4.4.3 Protection of crew (continue)

<p>(NOTES)</p> <p>1. <math>A_f^*</math> and <math>H_s^{**}</math> is to be as following.</p> <p style="padding-left: 40px;"><math>A_f^*</math> : The minimum summer freeboard calculated as Type <i>A</i> ship regardless of the type freeboard actually assigned.</p> <p style="padding-left: 40px;"><math>H_s^{**}</math> : the standard height of superstructure as defined in <b>ICLL Regulation 33</b>.</p> <p>2. Protection methods are to be as following (a) to (f)</p> <p>(a) A well lighted and ventilated under-deck passageway (clear opening 0.8 m wide, 2.0 m high) as close as practicable to the freeboard deck, connecting and providing access to the locations in question.</p> <p>(b) A permanent and efficiently constructed gangway fitted at or above the level of the superstructure deck on or as near as practicable to the center line of the ship, providing a continuous platform at least 0.6 m in width and a non-slip surface, with guard rails extending on each side throughout its length. Guard rails shall be at least 1 m high with courses as required in Load Line Regulation 25(3), and supported by stanchions spaced not more than 1.5 m ; a foot-stop shall be provided.</p> <p>(c) A permanent walkway at least 0.6 m in width fitted at freeboard deck level consisting of two rows of guard rails with stanchions spaced not more than 3 m. The number of courses of rails and their spacing are to be as required by Regulation 25(3). On Type <i>B</i> ships, hatchway coamings not less than 0.6 m in height may be regarded as forming one side of the walkway, provided that between the hatchways two rows of guard rails are fitted.</p> <p>(d) A 10 mm minimum diameter wire rope lifeline supported by stanchions about 10 m apart, or A single hand rail or wire rope attached to hatch coamings, continued and adequately supported between hatchways.</p> <p>(e) A permanent and efficiently constructed gangway fitted at or above the level of the superstructure deck on or as near as practicable to the center line of the ship: (2017)</p> <ul style="list-style-type: none"> <li>- located so as not to hinder easy access across the working areas of the deck;</li> <li>- providing a continuous platform at least 1.0 m in width;</li> <li>- constructed of fire resistant and non-slip material;</li> <li>- Fibre Reinforced Plastic(FRP) gratings used in lieu of steel gratings for safe access to tanker bows shall possess: <ul style="list-style-type: none"> <li>(i) low flame spread characteristics and shall not generate excessive quantities of smoke and toxic products as per the International Code for Application of Fire Test Procedures, 2010 (2010 FTP Code); and</li> <li>(ii) adequate structural fire integrity as per recognized standards(1) after undergoing tests in accordance with the above standards.</li> </ul> </li> <li>- fitted with guard rails extending on each side throughout its length; guard rails should be at least high with courses as required by Regulation 25(3) and supported by stanchions spaced not more than 1.5 m;</li> <li>- provided with a foot stop on each side;</li> <li>- having openings, with ladders where appropriate, to and from the deck. Openings should not be more than 40 m apart;</li> <li>- having shelters of substantial construction set in way of the gangway at intervals not exceeding 45 m if the length of the exposed deck to be traversed exceeds 70 m. Every such shelter should be capable of accommodating at least one person and be so constructed as to afford weather protection on the forward, port and starboard sides.</li> </ul> <p>(f) A permanent and efficiently constructed walkway fitted at freeboard deck level on or as near as practicable to the center line of the ship having the same specifications as those for a permanent gangway listed in (e) except for foot-stops. On Type <i>B</i> ships (certified for the carriage of liquids in bulk), with a combined height of hatch coaming and fitted hatch cover of together not less than 1 m in height the hatchway coamings may be regarded as forming one side of the walkway, provided that between the hatchways two rows of guard rails are fitted.</p> <p>3. Alternative transverse locations for 2. (c), (d) and (f) above, where appropriate:</p> <ol style="list-style-type: none"> <li>(1) At or near center line of ship; or Fitted on hatchways at or near center line of ship.</li> <li>(2) Fitted on each side of the ship.</li> <li>(3) Fitted on one side of the ship, provision being made for fitting on either side.</li> <li>(4) Fitted on one side only.</li> <li>(5) Fitted on each side of the hatchways as near to the center line as practicable</li> </ol> <p>(Notes)</p> <p>(1) For example, the Standard Specification for Fibre Reinforced Polymer (FRP) Gratings Used in Marine Construction and Shipbuilding (ASTM F3059-14). (2017)</p>
--

## CHAPTER 7 [Empty]

## CHAPTER 8 EQUIPMENT NUMBER AND EQUIPMENT

### Section 1 General

#### 101. General and application [See Rule]

##### 1. Consideration for restricted navigation area

- (1) Ships assigned with class notation "Smooth water service" may be provided the equipment in accordance with the equipment letter of equipment number which is one grade lower class of equipment letter.
- (2) In case of the above (1), the provisions of the used material may not be considered.

##### 2. Due to be assigned scantling draft( $d_s$ ), if draft( $d_f$ ) for designed ship and draft assigning is smaller than designed draft( $d$ ), equipment number and equipment are to be as follows:

- (1) For scantling draft( $d_s$ ), equipment number and equipment corresponded with scantling draft ( $d_s$ ) is to be equipped. In this case, if  $d_s - d$  is not less than 300 mm, ship length ( $L_s$ ) corresponded with  $d_s$  is to be used.
- (2) If  $d_f$  is not less than  $d$  (for ship assigned  $d_s$ ,  $d_f > d_s$ ), equipment number and equipment are to be decided by the scantling which is corresponded with  $d_f$ . If  $d_f - d$  is not less than 300 mm, equipment number is to be calculated with ship length which is corresponded with  $d_f$ .

##### 3. Superstructure which is not regarded as a deckhouse due to strength

Even though superstructure is not regarded as a deckhouse due to strength, if side wall is extended to side shell and deck is provided, it may be regarded as a superstructure. However, for the superstructure having unusually short end parts of deckhouse may be regarded as a deckhouse.

##### 4. Design of the anchoring equipment (2018)

- (1) The anchoring equipment required herewith is intended for temporary mooring of a ship within a harbour or sheltered area when the ship is awaiting berth, tide, etc. **Annex 4-3** may be referred to for recommendations concerning anchoring equipment for ships in deep and unsheltered water. (2019)
- (2) The Equipment Number (EN) formulae for anchoring equipment as given in **201.** of the Rules are based on an assumed maximum current speed of 2.5 m/s, maximum wind speed of 25 m/s and a minimum scope of chain cable of 6, the scope being the ratio between length of chain paid out and water depth. For ships with an equipment length greater than 135 m, alternatively the required anchoring equipment can be considered applicable to a maximum current speed of 1.5 m/s, a maximum wind speed of 11 m/s and waves with maximum significant height of 2 m.
- (3) It is assumed that under normal circumstances a ship will use only one bow anchor and chain cable at a time.

#### 104. Tests and inspections [See Rule]

In **104. 3** of the Rules, the "appropriate certificates accepted by the Society" means the certificates issued by any Society which is subject to verification of compliance with QSCS(Quality System Certification Scheme) of IACS and the relevant flag state or MED certificates.

## Section 2 Equipment Number

### 201. Equipment number [See Rule]

1. The equipment number of tug boat is to be following formula;

$$E = \Delta^{\frac{2}{3}} + 2(B \times f + \Sigma bh) + 0.1A$$

$b$  = maximum breadth of superstructure or deck house at each floor(m)

$h$  = each height of superstructure having breadth greater than  $B/4$  or each deckhouse(m).

#### 2. Significant figures

- (1) The scantling unit(m) of length, height, breadth has two significant figures and third figure is raised to a unit.
- (2)  $\Delta$  has a only positive number.
- (3) Each item of formula

( $\Delta^{\frac{2}{3}}$ ,  $2.0Bh$ ,  $0.1A$ ) has a only positive number with raising to unit from first figure.

#### 3. $\Delta$ , $f$

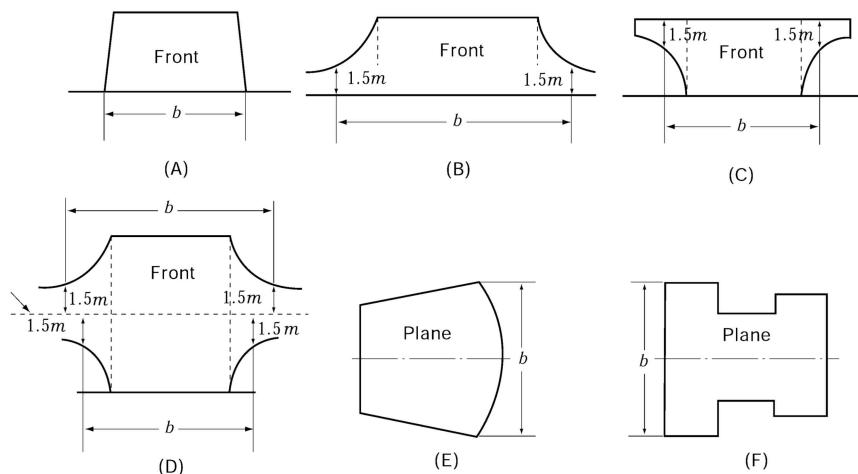
- (1) The values of  $\Delta$ ,  $f$  is to be in accordance with designed summer load line. However, ships assigned scantling draft  $d_s$  use the value  $d_s$ .
- (2) When the principle dimensions( $L$ ,  $B$  and  $D$ ) is changed (for example,  $L$  is changed when  $d_f - d$  is greater than 300 mm), equipment number may be recalculated.
- (3) When draft is changed, it is in accordance with the regulation **101. 2** of this chapter.

#### 4. Extents of structures to be included in the second term ( $2.0Bh$ ) of formula

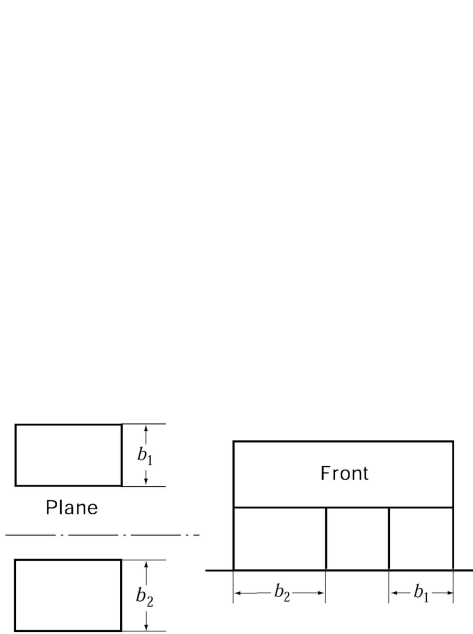
- (1) The following items are to be included into the calculation of  $h'$ .
  - (A) superstructures
  - (B) deckhouses having a breadth greater than  $B/4$
  - (C) screens or bulwarks higher than 1.5 m and in continuation to deckhouse, the total breadth of which exceeds  $B/4$  (See **Fig 4.8.4**)
- (2) The structures specified in (1) above are to be treated as divided at the intermediate deck into the upper and lower structures, the breadths of which are to be measured as respective tiers.

#### 5. Measurement of breadth of superstructures

- (1) A continuous superstructure or deck-house situated on one tier is to be treated as a single structure irrespective of the mode of variation of their breadth and height-continuous or discontinuous, and the breadth is to be the largest one as shown in **Fig 4.8.1**.

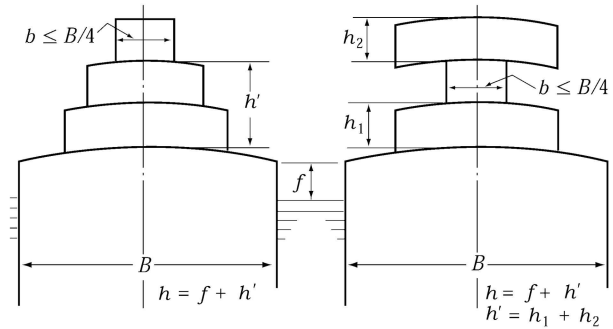
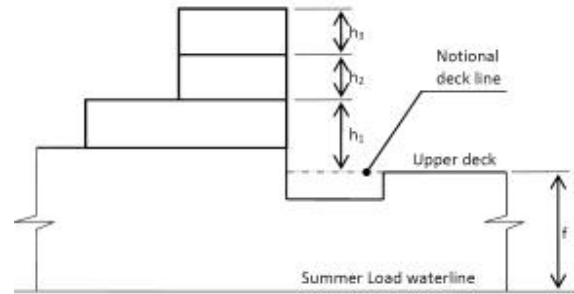


**Fig 4.8.1**



When  $b_1, b_2 < B/4$  (regardless of  $b_1+b_2$ ), it is not included.

Fig 4.8.2



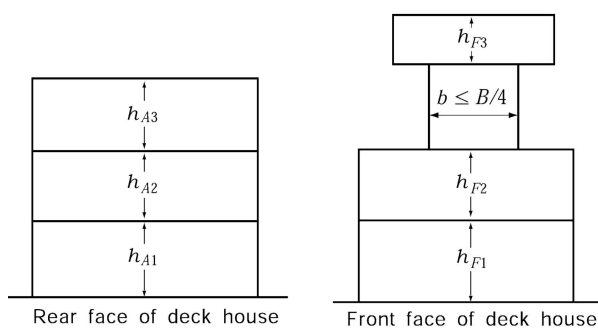
$f$  is to be measured from transverse section of ship

Fig 4.8.3 (2018)

(2) As for detached independent deck-houses on one tier, breadths of respective deckhouses are to be measured separately to determine whether they should be included or not. (See Fig 4.8.2)

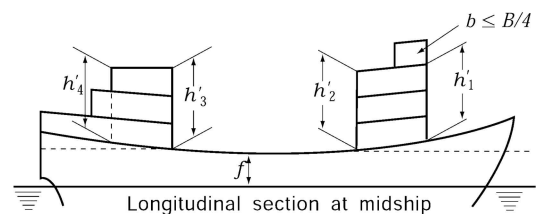
**6. Measurement of heights ( $h'$ ) of structures**

- (1)  $h'$  is to be the height at the ship centreline and is to be measured as shown in Fig 4.8.3.
- (2) Where there are detached structures,  $h'$  is to be determined for respective structures independently and the maximum value is to be taken as the height. (See Fig 4.8.4)
- (3) Where the between deck height varies longitudinally,  $h'$  is to be the maximum value measured from the uppermost continuous deck in the longitudinal section along the ship centreline (See Fig 4.8.5)



$$h' = \begin{matrix} h_{A1} + h_{A2} + h_{A3} \\ h_{F1} + h_{F2} + h_{F3} \end{matrix} \text{ whichever is greater}$$

Fig 4.8.4



$$h = f + h'$$

$$h' : h'_1, h'_2, h'_3 \text{ and } h'_4 \text{ whichever is greater}$$

Fig 4.8.5

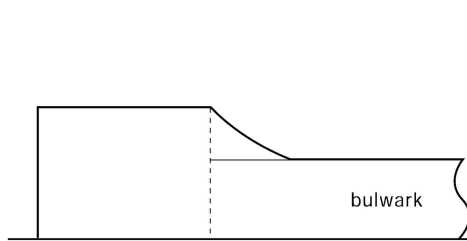
**7. Extents of structures to be included in the third term (0.1A) of the formula.**

- (1) The following items are to be included in  $\Sigma h''l$ .
  - (A) Superstructures

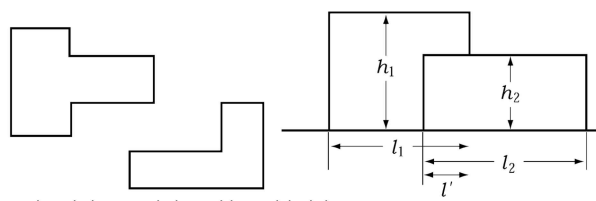
- (B) Deckhouses and trunks having breadth exceeding  $B/4$  and heights exceeding 1.5 m (See the above **Par 5**, as to measurement of breadth)
  - (C) Screens and bulwarks higher than 1.5 m in continuation to superstructure or to deckhouses having breadth exceeding  $B/4$  (See **Fig 4.8.7**)
  - (D) The following items may be excluded from the calculation of  $\Sigma h''l$ 
    - (a) portions outside the fore and aft ends of  $L$
    - (b) derrick posts, ventilators, etc. in continuation to superstructures or deckhouses
    - (c) hatch coamings and hatch covers
    - (d) funnels
    - (e) cargoes on decks
- (2) The structures specified in (1) above are to be treated as divided into the upper and lower structures at the intermediate deck, and the values of  $\Sigma h''l$  are to be calculated for respective tiers.

**8. Measurement of length of structures**

- (1) A continuous superstructure or deck house situated on one tier to be treated as a single superstructure or deckhouse even when its breadth and/or height vary discontinuously. The length is to be the maximum extreme length of the structure. However, where the height is changeable of deckhouse, the end parts or deckhouse having less than 1.5 m height to the middle of deckhouse height may be neglected. (See **Fig 4.8.6**)
- (2) Bulwarks in continuation to superstructures or deckhouses are to be treated in a the same manner as (1) above. (See **Fig 4.8.7**)

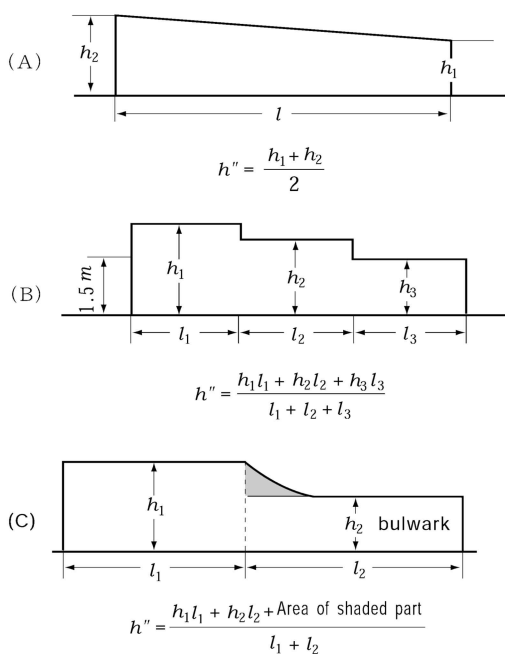


**Fig 4.8.7**

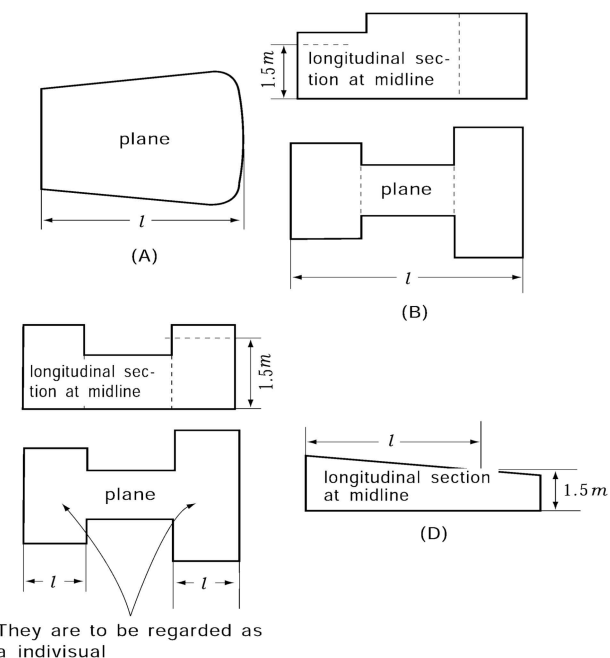


It is restricted that each breadth and height of deck house is over  $B/4$  and 1.5 m.  $h''l = h_1l_1 + h_2(l_2 - l_1)$

**Fig 4.8.9**



**Fig 4.8.8**



They are to be regarded as a individual

**Fig 4.8.6**

### 9. Measurement length to height( $h''$ ) of structures

- (1) The height of structures ( $h''$ ) covering the ship's centreline, such as super structures, deckhouse, etc. is to be the between deck height of respective tiers of structure at the centreline.
- (2) Where the deck height varies longitudinally,  $h''$  is to be determined as shown in **Fig 4.8.8**.
- (3) The height of structures not covering the ship's centreline is to be measured at the side facing to the centreline.

### 10. Where structure stand side by side

- (1) Where two or more deckhouse stand side by side transversely,  $h''l$  may be the projected plane of longitudinal section. (See **Fig 4.8.9**)
- (2) Screens and bulwark are to be treated in a same manner as (1) above.

### 11. Calculation $h''l$ of pressured LPG tanks

The  $h''l$  of the upper portions of LPG tanks above the upper deck which is included into  $h''l$  according to above **Par 8**. is to be the projected area on the longitudinal section along the ship's centreline.

### 12. Mooring lines for ships with EN > 2000 (2018)

The minimum recommended strength and number of mooring lines for ships with an Equipment Number EN > 2000 are given in (1) and (2), respectively. The length of mooring lines is given by (3).

The strength of mooring lines and the number of head, stern, and breast lines for ships with an Equipment Number EN > 2000 are based on the side-projected area A1. Side projected area A1 should be calculated similar to the side-projected area A according to **201**. of the rules but considering the following conditions:

- For oil tankers, chemical tankers, bulk carriers, and ore carriers the lightest ballast draft should be considered for the calculation of the side-projected area A1. For other ships the lightest draft of usual loading conditions should be considered if the ratio of the freeboard in the lightest draft and the full load condition is equal to or above two. Usual loading conditions mean loading conditions as given by the trim and stability booklet that are to be expected to regularly occur during operation and, in particular, excluding light weight conditions, propeller inspection conditions, etc.
- Wind shielding of the pier can be considered for the calculation of the side-projected area A1 unless the ship is intended to be regularly moored to jetty type piers. A height of the pier surface of 3 m over waterline may be assumed, i.e. the lower part of the side-projected area with a height of 3 m above the waterline for the considered loading condition may be disregarded for the calculation of the side-projected area A1.
- Deck cargo as given by the loading manual should be included for the determination of side-projected area A1. Deck cargo may not need to be considered if a usual light draft condition without cargo on deck generates a larger side-projected area A1 than the full load condition with cargo on deck. The larger of both side-projected areas should be chosen as side-projected area A1.

The mooring lines as given here under are based on a maximum current speed of 1.0 m/s and the following maximum wind speed  $v_w$ , in m/s:

$$\begin{aligned}
 V_w &= 25.0 - 0.002(A_1 - 2000) & : & \text{ for passenger ships, ferries, and car carriers with} \\
 & & & 2000 \text{ m}^2 < A_1 \leq 4000 \text{ m}^2 \\
 &= 21.0 & : & \text{ for passenger ships, ferries, and car carriers with } A_1 > 4000 \text{ m}^2 \\
 &= 25.0 & : & \text{ for other ships}
 \end{aligned}$$

The wind speed is considered representative of a 30 second mean speed from any direction and at a height of 10 m above the ground. The current speed is considered representative of the maximum

current speed acting on bow or stern ( $\pm 10^\circ$ ) and at a depth of one-half of the mean draft. Furthermore, it is considered that ships are moored to solid piers that provide shielding against cross current.

Additional loads caused by, e.g., higher wind or current speeds, cross currents, additional wave loads, or reduced shielding from non-solid piers may need to be particularly considered. Furthermore, it should be observed that unbeneficial mooring layouts can considerably increase the loads on single mooring lines.

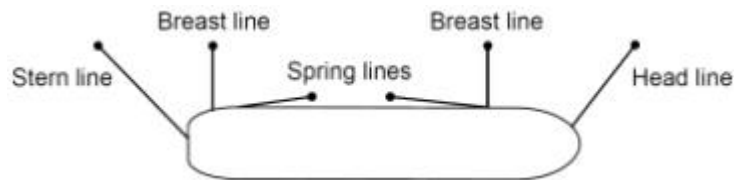
Note:

The following is defined with respect to the purpose of mooring lines, see also figure below:

Breast line: A mooring line that is deployed perpendicular to the ship, restraining the ship in the off-berth direction.

Spring line: A mooring line that is deployed almost parallel to the ship, restraining the ship in fore or aft direction.

Head/Stern line: A mooring line that is oriented between longitudinal and transverse direction, restraining the ship in the off-berth and in fore or aft direction. The amount of restraint in fore or aft and off-berth direction depends on the line angle relative to these directions.



(1) Minimum breaking strength

The minimum breaking strength, in kN, of the mooring lines should be taken as:

$$MBL = 0.1 \cdot A_1 + 350$$

The minimum breaking strength may be limited to 1275 kN (130 t). However, in this case the moorings are to be considered as not sufficient for environmental conditions given by this section. For these ships, the acceptable wind speed  $v_w^*$ , in m/s, can be estimated as follows:

$$V_w^* = V_w \cdot \sqrt{\frac{MBL^*}{MBL}}$$

where  $v_w$  is the wind speed as per this section,  $MBL^*$  the breaking strength of the mooring lines intended to be supplied and  $MBL$  the breaking strength as recommended according to the above formula. However, the minimum breaking strength should not be taken less than corresponding to an acceptable wind speed of 21 m/s:

$$MBL^* \geq \left(\frac{21}{V_w}\right)^2 \cdot MBL$$

If lines are intended to be supplied for an acceptable wind speed  $v_w^*$  higher than  $v_w$  as per 2.1.2, the minimum breaking strength should be taken as:

$$MBL^* \geq \left(\frac{V_w^*}{V_w}\right)^2 \cdot MBL$$

(2) Number of mooring lines

The total number of head, stern and breast lines (see Note in 2.1.2) should be taken as:

$$n = 8.3 \cdot 10^{-4} \cdot A_1 + 6$$

For oil tankers, chemical tankers, bulk carriers, and ore carriers the total number of head, stern and breast lines should be taken as:

$$n = 8.3 \cdot 10^{-4} \cdot A_1 + 4$$

The total number of head, stern and breast lines should be rounded to the nearest whole number.

The number of head, stern and breast lines may be increased or decreased in conjunction with an adjustment to the strength of the lines. The adjusted strength,  $MBL^*$ , should be taken as:

$$MBL^* = 1.2 \cdot MBL \cdot n/n^* \leq MBL \quad \text{for increased number of lines,}$$

$$MBL^* = MBL \cdot n/n^* \quad \text{for reduced number of lines.}$$

where  $n^*$  is the increased or decreased total number of head, stern and breast lines and  $n$  the number of lines for the considered ship type as calculated by the above formulas without rounding.

Vice versa, the strength of head, stern and breast lines may be increased or decreased in conjunction with an adjustment to the number of lines.

The total number of spring lines (see Note in this section) should be taken not less than:

Two lines where  $EN < 5000$ ,

Four lines where  $EN \geq 5000$ .

The strength of spring lines should be the same as that of the head, stern and breast lines. If the number of head, stern and breast lines is increased in conjunction with an adjustment to the strength of the lines, the number of spring lines should be likewise increased, but rounded up to the nearest even number.

(3) Length of mooring lines

For ships with  $EN > 2000$  the length of mooring lines may be taken as 200 m.

The lengths of individual mooring lines may be reduced by up to 7% of the above given lengths, but the total length of mooring lines should not be less than would have resulted had all lines been of equal length.

**13. Tow line (2018)**

The tow lines are given in **Table 4.8.1** of the rules and are intended as own tow line of a ship to be towed by a tug or other ship. For the selection of the tow line from **Table 4.8.1** of the rules, the Equipment Number EN should be taken according to **12**.

**203. Chain cables and stream lines [See Rule]**

1. Steel wire rope instead of stud link chain cable may be accepted for vessels of special design or operation such as crane barges if recognized by the Society. The acceptance will be based on a case-by-case evaluation, including consideration of operational and safety aspects. If steel wire rope is accepted, the following to be fulfilled.

- (1) The steel wire rope shall have at least the same breaking strength as the stud link chain cable.
- (2) The length of the steel wire rope shall be at least 50 % above the table value for the chain cable.
- (3) The anchor weight shall be increased by 25 %.
- (4) A length of chain cable shall be fitted between the anchor and the steel wire rope. The length

shall be taken as the smaller of the follows.

(A) 12.5 m

(B) The distance between the anchor in stowed position and the winch

2. The Society may consider the acceptance if the effect of mooring equipment for operating condition is equivalent to the Rules to the satisfaction to the Society.

### **Section 3 Anchors**

#### **304. Constructions and dimensions [See Rule]**

In the Rules, "holding power indicated by the Society" means 2 times of holding power to stockless anchor having same mass in case of high holding power anchors and 4 times of holding power to stockless anchor having same mass in case of super high holding power anchors by the results of holding power test by the type approval tests in **Ch 3, Sec 6** of the **Guidance for Approval of Manufacturing Process and Type Approval, Etc.**

### **Section 4 Chains**

#### **401. Application [See Rule]**

1. "Chafing chain for Emergency Towing Arrangements (ETA)" specified in **Pt 4, Ch 8, 401. 2** of the Rules are as follows.
  - (1) Scope  
These requirements apply to the chafing chain for chafing gear of two types of Emergency Towing Arrangements (ETA) with specified safe working load (SWL) of 1,000kN (ETA1000) and 2,000kN (ETA2000). Chafing chains other than those specified can be used subject to special agreement with the Society.
  - (2) Approval of manufacturing  
The chafing chain is to be manufactured by works approved by the Society.
  - (3) Materials  
The materials used for the manufacture of the chafing chain are to satisfy the requirements in **403.** of the Rules.
  - (4) Design, manufacture, testing and certification of chafing chain
    - (A) The chafing chain is to be designed, manufactured, tested and certified in accordance with the requirements in **Pt 4, Ch 8, Sec 4** of the Rules.
    - (B) The arrangement at the end connected to the strongpoint and the dimensions of the chafing chain are determined by the type of ETA. The other end of the chafing chain is to be fitted with a pear-shaped open link allowing connection to a shackle corresponding to the type of ETA and chain cable grade. A typical arrangement of this chain end is shown in **Fig 4.8.10.**

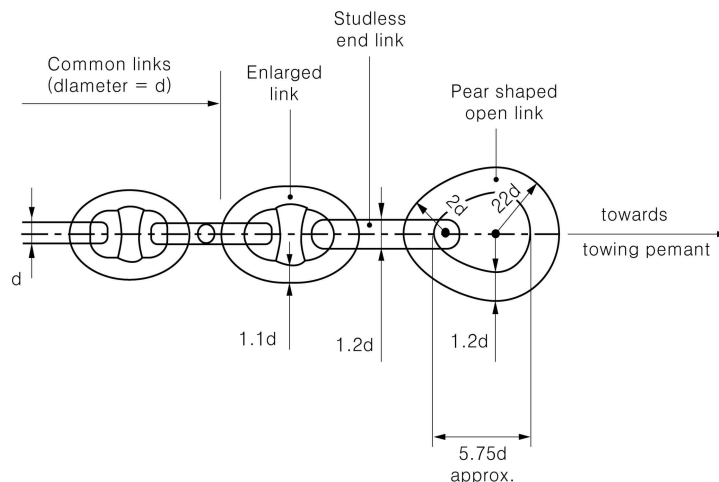


Fig 4.8.10 Typical outboard chafing chain end

- (C) The common link is to be of stud link type grade 2 or 3.  
 (D) The chafing chain is to be able to withstand a breaking load not less than twice the SWL. For each type of ETA, the nominal diameter of common link for chafing chains is to comply with the value indicated in **Table 4.8.1**.

Table 4.8.1. Nominal diameter of common link for chafing chains

Type of ETA	Nominal diameter of common link, d min.	
	Grade 2	Grade 3
ETA1000	62mm	52mm
ETA2000	90mm	76mm

2. "The Offshore mooring chains deemed appropriate by the Society" specified in **Pt 4, Ch 8, 401. 2** of the Rules are as follows. (2017)

(1) General

(A) Scope

- These requirements apply to the materials, design, manufacture and testing of offshore mooring chain and accessories intended to be used for applications such as: mooring of mobile offshore units, mooring of floating production units, mooring of offshore loading systems and mooring of gravity based structures during fabrication.
- Mooring equipment covered are common stud and studless links, connecting common links (splice links), enlarged links, end links, detachable connecting links (shackles), end shackles, subsea connectors, swivels and swivel shackles.
- Studless link chain is normally deployed only once, being intended for long-term permanent mooring systems with pre-determined design life.
- Requirements for chafing chain for single point mooring arrangements are given in **Par 3**.

(B) Chain grades

- Depending on the nominal tensile strength of the steels used for manufacture, chains are to be subdivided into five grades, i.e.: R3, R3S, R4, R4S and R5.
- Manufacturers propriety specifications for R4S and R5 may vary subject to design conditions and the acceptance of the Society.
- Each Grade is to be individually approved. Approval for a higher grade does not constitute approval of a lower grade. If it is demonstrated to the satisfaction of the Society that the higher and lower grades are produced to the same manufacturing procedure using the same chemistry and heat treatment, consideration will be given to qualification of a lower grade by a higher. The parameters applied during qualification are not to be modified during production.

(2) Materials

- (A) Offshore chains are to be made of the materials given in **Table 4.8.2** of the Guidance according to their grades and manufacturing processes, respectively.  
(B) Accessories for offshore chains are to be made of the materials given in **Table 4.8.3** of the Guidance corresponding to the grades of the connected offshore chain.

**Table 4.8.2 Materials for offshore chain link**

Kind of offshore chain	Materials	Grade of material
Grade <i>R</i> 3	Grade <i>R</i> 3 offshore chain bar	<i>RSBCR</i> 3
Grade <i>R</i> 3S	Grade <i>R</i> 3S offshore chain bar	<i>RSBCR</i> 3S
Grade <i>R</i> 4	Grade <i>R</i> 4 offshore chain bar	<i>RSBCR</i> 4
Grade <i>R</i> 4S	Grade <i>R</i> 4S offshore chain bar	<i>RSBCR</i> 4S
Grade <i>R</i> 5	Grade <i>R</i> 5 offshore chain bar	<i>RSBCR</i> 5

**Table 4.8.3 Materials for accessories of offshore chains**

Kind of connected offshore chain	Manufacturing process			
	Casting	Grade of material	Forging	Grade of material
Grade <i>R</i> 3	Grade <i>R</i> 3 steel casting	<i>RSCCR</i> 3	Grade <i>R</i> 3 steel forging	<i>RSFCR</i> 3
Grade <i>R</i> 3S	Grade <i>R</i> 3S steel casting	<i>RSCCR</i> 3S	Grade <i>R</i> 3S steel forging	<i>RSFCR</i> 3S
Grade <i>R</i> 4	Grade <i>R</i> 4 steel casting	<i>RSCCR</i> 4	Grade <i>R</i> 4 steel forging	<i>RSFCR</i> 4
Grade <i>R</i> 4S	Grade <i>R</i> 4S steel casting	<i>RSCCR</i> 4S	Grade <i>R</i> 4S steel forging	<i>RSFCR</i> 4S
Grade <i>R</i> 5	Grade <i>R</i> 5 steel casting	<i>RSCCR</i> 5	Grade <i>R</i> 5 steel forging	<i>RSFCR</i> 5

(3) Design and manufacture

(A) Design

- (a) Drawings accompanied by design calculations, giving detailed design of chain and accessories made by or supplied through the chain manufacturer are to be submitted for approval. Typical designs are given in ISO 1704. For studless chain the shape and proportions are to comply with the requirements of this paragraph. Other studless proportions are to be specially approved. It should be considered that new or non-Standard designs of chain, shackles or fittings, may require a fatigue analysis and possible performance, fatigue or corrosion fatigue testing.  
(b) In addition, for stud link chain, drawings showing the detailed design of the stud shall be submitted for information. The stud shall give an impression in the chain link which is sufficiently deep to secure the position of the stud, but the combined effect of shape and depth of the impression shall not cause any harmful notch effect or stress concentration in the chain link.  
(c) Machining of Kenter shackles shall result in fillet radius min. 3 percent of nominal diameter.

(B) Chain cable manufacturing process

(a) General

- (i) Offshore mooring chains are to be manufactured only by works approved by the Classification Society. For this purpose approval tests are to be carried out, the scope of which is to include proof and breaking load tests, measurements and mechanical tests including fracture mechanics tests.

- (ii) Offshore mooring chains shall be manufactured in continuous lengths by flash butt welding and are to be heat treated in a continuous furnace; batch heat treatment is not permitted, except in special circumstances where short lengths of chain are delivered, such as chafing chain. (Ref. **Par 3**).
- (iii) The use of joining shackles to replace defective links is subject to the written approval of the end purchaser in terms of the number and type permitted. The use of connecting common links is restricted to 3 links in each 100 m of chain.
- (b) Chain cable manufacturing process records
  - Records of bar heating, flash welding and heat treatment shall be made available for inspection by the Surveyor.
- (c) Bar heating
  - (i) Bars for links shall be heated by electric resistance, induction or in a furnace.
  - (ii) For electric resistance heating or induction heating, the heating phase shall be controlled by an optical heat sensor. The controller shall be checked at least once every 8 hours and records made.
  - (iii) For furnace heating, the heat shall be controlled and the temperature continuously recorded using thermocouples in close proximity to the bars. The controls shall be checked at least once every 8 hours and records made.
- (d) Flash welding of chain cable
  - (i) The following welding parameters shall be controlled during welding of each link:
    - ① Platen motion
    - ② Current as a function of time
    - ③ Hydraulic pressure
  - (ii) The controls shall be checked at least every 4 hours and records made.
- (e) Heat treatment of chain cable
  - (i) Chain shall be austenitized, above the upper transformation temperature, at a combination of temperature and time within the limits established.
  - (ii) When applicable, chain shall be tempered at a combination of temperature and time within the limits established. Cooling after tempering shall be appropriate to avoid temper embrittlement.
  - (iii) Temperature and time or temperature and chain speed shall be controlled and continuously recorded.
  - (iv) Grain determination shall be made for the final product. The austenitic grain size for R3, R3S, R4, R4S and R5 is to be 6 or finer in accordance with ASTM E112 or equivalent grain size index in accordance to ISO 643. Measurements for circular sections are to be taken at surface, 1/3 radius and centre for the base material, HAZ and weld.
- (f) Mechanical properties
  - (i) The mechanical properties of finished chain and accessories are to be in accordance with **Table 4.8.4** of the Guidance. For the location of test specimens see **Fig 1**. of **Pt 2, Annex 2-9** of the Guidance and **Fig 4.8.11** of the Guidance.
- (g) Proof and breaking test loads
  - (i) Chains and accessories are to withstand the proof and break test loads given in **Table 4.8.5** of the Guidance.
- (h) Freedom from defects
  - (i) All chains are to have a workmanlike finish consistent with the method of manufacture and be free from defects. Each link is to be examined in accordance with **(4) (E)** using approved procedures.

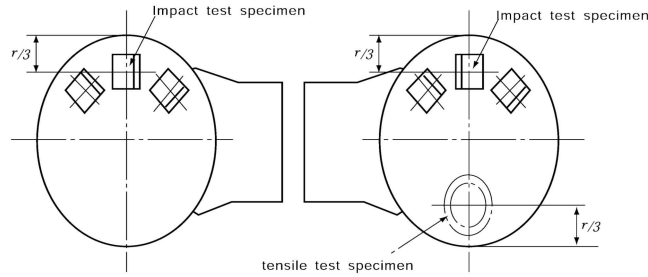


Fig 4.8.11 Sampling of chain links

Table 4.8.4 Mechanical properties

Kinds of offshore chains	Tensile test				Impact test(1)		
	Yield strength(2) (N/mm <sup>2</sup> )	Tensile strength(2) (N/mm <sup>2</sup> )	Elongation (L = 5d)(%)	Reduction of area (%)	Testing temperature (°C)	Minimum mean absorbed energy (J)	
						except welded part	welded part
Grade R 3	410 min.	690 min.	17 min.	50 min.	-20(3)	40 min.(3)	30 min.(3)
Grade R 3S	490 min.	770 min.	15 min.	50 min.	-20(3)	45 min.(3)	33 min.(3)
Grade R 4	580 min.	860 min.	12 min.	50 min.	-20	50 min.	36 min.
Grade R 4S	700 min.	960 min.	12 min.	50 min.	-20	56 min.	40 min.
Grade R 5	760 min.	1000 min.	12 min.	50 min.	-20	58 min.	42 min.

(Notes)

- (1) When the absorbed energy of two or more test specimens among a set of test specimens is less in value than the specified minimum mean absorbed energy or when the absorbed energy of a single test specimen is less in value 70 % of the specified minimum mean absorbed energy, the test is considered to have failed.
- (2) Aim value of yield to tensile ration is maximum 0.92
- (3) Impact test of Grade R 3 and R 3S offshore chains may be carried out at the temperature of 0°C where approved by the Society. In this case, minimum mean absorbed energy is not to be less than following values.

	except welded part	welded part
(a) Grade R 3	60 J	50 J
(b) Grade R 3S	65 J	53 J

Table 4.8.5 Breaking and proof test loads, mass and length over 5 links for offshore chains

Test Load	Grade R3 Stud Link	Grade R3S Stud Link	Grade R4 Stud Link	Grade R4S Stud Link	Grade R5 Stud Link
Proof test load (kN)	$0.0148d^2(44-0.08d)$	$0.0180d^2(44-0.08d)$	$0.0216d^2(44-0.08d)$	$0.0240d^2(44-0.08d)$	$0.0251d^2(44-0.08d)$
Breaking test load (kN)	$0.0223d^2(44-0.08d)$	$0.0249d^2(44-0.08d)$	$0.0274d^2(44-0.08d)$	$0.0304d^2(44-0.08d)$	$0.0320d^2(44-0.08d)$
Test Load	Grade R3 Studless	Grade R3S Studless	Grade R4 Studless	Grade R4S Studless	Grade R5 Studless
Proof test load (kN)	$0.0148d^2(44-0.08d)$	$0.0174d^2(44-0.08d)$	$0.0192d^2(44-0.08d)$	$0.0213d^2(44-0.08d)$	$0.0223d^2(44-0.08d)$
Breaking test load (kN)	$0.0223d^2(44-0.08d)$	$0.0249d^2(44-0.08d)$	$0.0274d^2(44-0.08d)$	$0.0304d^2(44-0.08d)$	$0.0320d^2(44-0.08d)$
Chain Weight (kg/m)	Stud Link = $0.0219d^2$				
	Studless chain Weight calculations for each design are to be submitted.				
Length over 5 links (mm)	over $22d$ up to $22.55d$				

- (i) Dimensions and dimensional tolerances
- (i) The shape and proportion of links and accessories must conform to ISO 1704:1991 or the designs specially approved.
- (ii) The following tolerances are applicable to links:
- ① The negative tolerance on the nominal diameter measured at the crown:

Nominal diameter (mm)	over		40	84	122	152	184
	up to	40	84	122	152	184	222
negative tolerance(mm)		-1	-2	-3	-4	-6	-7.5

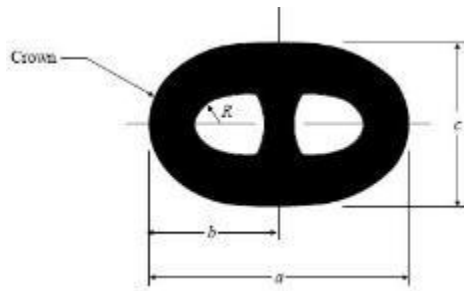
Note 1: The cross sectional area at the crown must have no negative tolerance. For diameters of 20 mm or greater, the plus tolerance may be up to 5 percent of the nominal diameter. For diameters less than 20 mm the plus tolerance is to be agreed with the Society at the time of approval. The cross sectional area at the crown must have no negative tolerance.

Note 2: The cross sectional area at the crown is to be calculated using the average of the diameters with negative tolerance and plus tolerance, measurements are to be taken from at least 2 locations approximately 90 degrees apart.

- ② Diameter measured at locations other than the crown:  
The diameter is to have no negative tolerance. The plus tolerance may be up to 5 percent of the nominal diameter. except at the butt weld where it is to be in accordance to manufacturer's specification, which is to be agreed with the Society. For diameters less than 20 mm, the plus tolerance is to be agreed with the Society at the time of approval.
- ③ The allowable manufacturing tolerance on a length of five links is + 2.5 percent, but may not be negative.

- ④ All other dimensions are subject to a manufacturing tolerance of  $\pm 2.5$  percent, provided always that all parts fit together properly.
- ⑤ The tolerances for stud link and studless common links are to be measured in accordance with **Fig 4.8.12** of the Guidance.
- ⑥ For stud link chains studs must be located in the links centrally and at right angles to the sides of the link. The following tolerances in **Fig 4.8.12** of the Guidance are acceptable provided that the stud fits snugly and its ends lie flush against the inside of the link:

Stud link - The internal link radii (R) and external radii should be uniform



Designation(1)	Description	Nominal Dimension of the Link	Minus Tolerance	Plus Tolerance
<i>a</i>	Link Length	$6d$	$0.15d$	$0.15d$
<i>b</i>	Link Half Length	$a^*/2$	$0.1d$	$0.1d$
<i>c</i>	Link Width	$3.6d$	$0.09d$	$0.09d$
<i>e</i>	Stud Angular Misalignment	0 degrees	4 degrees	4 degrees
<i>R</i>	Inner Radius	$0.65d$	0	-----

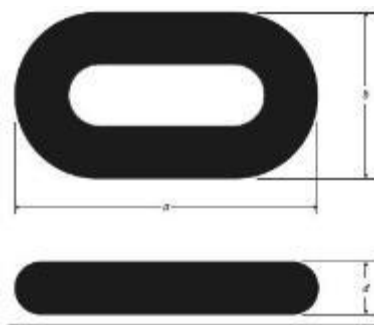
Notes:

(1) Dimension designation is shown in above figure.

*d* = Nominal diameter of chain

*a\** = Actual link length

Studless - The internal link radii (R) and external radii should be uniform.



Designation(1)	Description	Nominal Dimension of the Link	Minus Tolerance	Plus Tolerance
<i>a</i>	Link Length	$6d$	$0.15d$	$0.15d$
<i>b</i>	Link Width	$3.35d$	$0.09d$	$0.09d$
<i>R</i>	Inner Radius	$0.65d$	0	-----

Notes:

- (1) Dimension designation is shown in above figure.  
 $d$  = Nominal diameter of chain
- (2) Other dimension ratios are subject to special approval.

**Fig 4.8.12 Stud link and studless common link, proportions dimensions and tolerances**

- (j) Stud link chain - welding of studs
  - (i) A welded stud may be accepted for grade R3 and R3S chains. Welding of studs in grades R4, R4S and R5 chain is not permitted unless specially approved.
  - (ii) Where studs are welded into the links this is to be completed before the chain is heat treated.
  - (iii) The stud ends must be a good fit inside the link and the weld is to be confined to the stud end opposite to the flash butt weld. The full periphery of the stud end is to be welded unless otherwise approved.
  - (iv) Welding of studs both ends is not permitted unless specially approved.
  - (v) The welds are to be made by qualified welders using an approved procedure and low-hydrogen approved consumables.
  - (vi) The size of the fillet weld shall as a minimum be as per API Specification 2F.
  - (vii) The welds are to be of good quality and free from defects such as cracks, lack of fusion, gross porosity and undercuts exceeding 1 mm.
  - (viii) All stud welds shall be visually examined. At least 10 per cent of all stud welds within each length of chain shall be examined by dye penetrant or magnetic particles after proof testing. If cracks or lack of fusion are found, all stud welds in that length are to be examined.
- (k) Connecting common links (splice links)
  - (i) Single links to substitute for test links or defective links without the necessity for reheat treatment of the whole length are to be made in accordance with an approved procedure. Separate approvals are required for each grade of chain and the tests are to be made on the maximum size of chain for which approval is sought.
  - (ii) Manufacture and heat treatment of connecting common link is not to affect the properties of the adjoining links. The temperature reached by these links is nowhere to exceed 250°C.
  - (iii) Each link is to be subjected to the appropriate proof load and non-destructive examination as detailed in **Table 4.8.5** of the Guidance and **(4) (E)**. A second link shall be made identical to the connecting common link; the link shall be tested and inspected per **(4) (D)** and **(E)**.
  - (iv) Each connecting common link is to be marked either; on the stud for stud link chain or, on the outer straight length on the side opposite the flash butt weld for studless chain. This marking is to be in accordance with **(4) (G)** plus a unique number for the link. The adjoining links are also to be marked on the studs or straight length as above.
- (4) Testing and inspection of finished chain
  - (A) General
    - (a) This Sub-paragraph applies to but is not limited to finished chain cable such as common stud and studless links, end links, enlarged end links and connecting common links (splice links).
    - (b) All chain is to be subjected to proof load tests, sample break load tests and sample mechanical tests after final heat treatment in the presence of a Surveyor. Where the manufacturer has a procedure to record proof loads and the Surveyor is satisfied with the adequacy of the recording system, he need not witness all proof load tests. The Surveyor is to satisfy himself that the testing machines are calibrated and maintained in a satisfactory condition. Prior to inspection the chain is to be free from scale, paint or other coating and is to have a suitably prepared surface as per the applied NDE testing standard. The chain shall be sand or shot blast to meet this requirement.
  - (B) Proof and break load tests
    - (a) The entire length of chain shall withstand the proof load specified in **Table 4.8.5** of the Guidance without fracture and shall not crack in the flash weld. The load applied shall not exceed the proof load by more than 10% when stretching the chain. Where plastic straining is used to set studs, the applied load is not to be greater than that

- qualified in approval tests.
- (b) A break-test specimen consisting of at least 3 links is to be either taken from the chain or produced at the same time and in the same manner as the chain. The test frequency is to be based on tests at sampling intervals according to **Table 4.8.6** of the Guidance provided that every cast is represented. Each specimen shall be capable of withstanding the break load specified without fracture and shall not crack in the flash weld. It shall be considered acceptable if the specimen is loaded to the specified value and maintained at that load for 30 seconds.
  - (c) For chain diameters over 100mm, alternative break-test proposals to the above breaktest will be considered whereby a one link specimen is used. Alternatives are to be approved by the Classification Society, every heat is to be represented, the test frequency is to be in accordance with **Table 4.8.6** of the Guidance, and it is to be demonstrated and proven that the alternative test represents an equivalent load application to the three link test.
  - (d) If the loading capacity of the testing machine is insufficient, an alternative load testing machine is to be used that does have sufficient capacity (e.g. two loading machines in parallel) provided the testing and calibration procedure are agreed with the Society.
- (C) Dimensions and dimensional tolerances
- (a) After proof load testing measurements are to be taken on at least 5 per cent of the links in accordance with **(3) (B) (i)**.
  - (b) The entire chain is to be checked for the length, five links at a time. By the five link check the first five links shall be measured. From the next set of five links, at least two links from the previous five links set shall be included. This procedure is to be followed for the entire chain length. The measurements are to be taken preferably while the chain is loaded to 5 - 10 % of the minimum proof load. The tolerances for the 5 link measurements are indicated in **Table 4.8.5** of the Guidance, any deviations from the 5 link tolerances are to be agreed by the client and Society. The links held in the end blocks may be excluded from this measurement.
  - (c) Chain dimensions are to be recorded and the information retained on file.

**Table 4.8.6 Number of breaking test**

Nominal diameter of offshore chain <i>d</i> (mm)	Maximum sampling interval(m)
$d \leq 48$	91
$48 < d \leq 60$	110
$60 < d \leq 73$	131
$73 < d \leq 85$	152
$85 < d \leq 98$	175
$98 < d \leq 111$	198
$111 < d \leq 124$	222
$124 < d \leq 137$	250
$137 < d \leq 149$	274
$149 < d \leq 162$	297
$162 < d \leq 175$	322
$175 < d \leq 186$	346
$186 < d \leq 198$	370
$198 < d \leq 210$	395
$210 < d \leq 222$	420

- (D) Mechanical tests
- (a) Links of samples detached from finished, heat treated chain shall be sectioned for determination of mechanical properties. A test unit shall consist of one tensile and nine im-

compact specimens. The tensile specimen shall be taken in the side opposite the flash weld. Three impact specimens shall be taken across the flash weld with the notch centred in the middle. Three impact specimens shall be taken across the unwelded side and three impact specimens shall be taken from the bend region.

- (b) The test frequency is to be based on tests at sampling intervals according to **Table 4.8.3** of the Guidance provided that every cast is represented. Mechanical properties shall be as specified in **Table 4.8.4** of the Guidance.
  - (c) The frequency of impact testing in the bend may be reduced at the discretion of the Society provided it is verified by statistical means that the required toughness is consistently achieved.
  - (d) Hardness tests are to be carried out on finished chain. The frequency and locations are to be agreed with the Society. The recorded values are for information only and used as an additional check to verify that the heat treatment process has been stable during the chain production.
- (E) Non-destructive examination after proof load testing
- (a) All surfaces of every link shall be visually examined. Burrs, irregularities and rough edges shall be contour ground. Links shall be free from mill defects, surface cracks, dents and cuts, especially in the vicinity where gripped by clamping dies during flash welding. Studs shall be securely fastened. Chain is to be positioned in order to have good access to all surfaces. In order to allow optimal access to the surface area it is recommended that chain be hung in the vertical position, however access to inspect the interlink area may only be possible with the chain in the horizontal position.
  - (b) Testing is to be performed in accordance with a recognized Standard and the procedures, together with acceptance/rejection criteria are to be submitted to the Society for review. Manufacturers shall prepare written procedures for NDE. NDE personnel shall be qualified and certified according to ISO 9712, ACCP or equivalent. Personnel qualification to an employer or responsible agency based qualification scheme as SNT-TC-1A may be accepted if the employer's written practice is reviewed and found acceptable and the Level III is ASNT Level III, ISO 9712 Level III or ACCP Professional Level III and certified in the applicable method. NDE operators shall be qualified to at least level II.
  - (c) Magnetic particles shall be employed to examine the flash welded area including the area gripped by the clamping dies. Procedures are to be submitted to the Society for approval. Procedures and equipment in accordance with those approved shall be used. Frequency of examination shall be every link. Additionally, 10% of links are to be tested on all accessible surfaces. Link surfaces and the surface at the flash weld shall be free from cracks, lack of fusion and gross porosity. Testing shall be performed in accordance with ASTM E709 or another recognized standard (e.g. ISO 9934) using wet continuous fluorescent magnetization technique. Non fluorescent techniques can be accepted in special cases where the standard inspection procedures are impractical.

Links shall be free from:

- relevant linear indications exceeding 1.6 mm in transverse direction
- relevant linear indications exceeding 3.2 mm in longitudinal direction
- relevant non-linear indications exceeding 4.8 mm.

- (d) Ultrasonics shall be employed to examine the flash weld fusion. Procedures are to be submitted to the Society for approval. Procedures and equipment in accordance with those approved shall be used. On-site calibration standards for chain configurations shall be approved. Frequency of examination shall be every link. The flash weld shall be free from defects causing ultrasonic back reflections equal to or greater than the calibration standard. The flash butt welds shall be ultrasonic tested (UT) in accordance with ASTM E587 or another recognized standard using single probe, angle-beam shear waves in the range from 45 to 70°.

Single probe technique has limitations as far as testing of the central region is concerned and the flash weld imperfections such as flat spots may have poor reflectivity. Where it is deemed necessary, detectability of imperfections may need to be carried out by using a tandem technique, TOFD or phased array.

- (e) Stud welds, if used, shall be visually inspected. The toes of the fillets shall have a smooth transition to the link with no undercuts exceeding 1.0 mm. Additionally, at least

10% of the stud welds distributed through the length shall be dye penetrant tested according to ASTM E1417 or magnetic particle tested according to ASTM E1444 or equivalent. Cracks, lack of fusion or gross porosity are not acceptable. If defects are found, testing shall be extended to all stud welds in that length.

- (F) Retest, rejection and repair criteria
- (a) If the length over 5 links is short, the chain may be stretched by loading above the proof test load specified provided that the applied load is not greater than that approved and that only random lengths of the chain need stretching. If the length exceeds the specified tolerance, the over length chain links shall be cut out and (b) shall apply.
  - (b) If single links are found to be defective or to do not meet other applicable requirements, defective links may be cut out and a connecting common link inserted in their place. The individual heat treatment and inspection procedure of connecting common links is subject to the Society's approval. Other methods for repair are subject to the written approval of the Society and the end purchaser. Weld repair of chain is not permitted.
  - (c) If a crack, cut or defect in the flash weld is found by visual or magnetic particle examination, it shall be ground down no more than 5% of the link diameter in depth and streamlined to provide no sharp contours. The final dimensions must still conform to the agreed standard.
  - (d) If indications of interior of flash weld defects, in reference to the accepted calibration standards are detected during ultrasonic examination, (b) shall apply.
  - (e) If link diameter, length, width and stud alignment do not conform to the required dimensions, these shall be compared to the dimensions of 40 more links; 20 on each side of the affected link. If a single particular dimension fails to meet the required dimensional tolerance in more than 2 of the sample links, all links shall be examined. (b) shall apply.
  - (f) If a break load test fails, a thorough examination with the Surveyor informed in a timely manner is to be carried out to identify the cause of failure. Two additional break test specimens representing the same sampling length of chain are to be subjected to the break load test. Based upon satisfactory results of the additional tests and the results of the failure investigation, it will be decided what lengths of chain can be accepted. Failure of either or both additional tests will result in rejection of the sampling length of chain represented and (b) shall apply.
  - (g) If a link fails during proof load testing, a thorough examination with the Surveyor informed in a timely manner is to be carried out to identify the probable cause of failure of the proof test. In the event that two or more links in the proof loaded length fail, that section of proof loaded length is to be rejected. The above failure investigation is to be carried out especially with regard to the presence in other lengths of factors or conditions thought to be causal to failure.
  - (h) In addition to the above failure investigation, a break test specimen is to be taken from each side of the one failed link, and subjected to the breaking test. Where multiple chains are produced simultaneously it is recognised that the preceding flash butt welded link and subsequent flash butt welded link will be on an alternative chain length or the other end of the chain length. In such cases the Classification Society may require that two additional break tests are to be taken from the lengths of chain that include the preceding and subsequent welded links. Based upon satisfactory results of both break tests and the results of the failure investigation, it will be decided what length of chain can be considered for acceptance. Failure of either or both breaking tests will result in rejection of the same proof loaded length. Replacement of defective links is to be in accordance with (b). If the investigation identifies defects in the flash butt weld or a lower strength flash weld "a glue-weld" is found, additional NDT such as phased array UT is to be carried out to identify if other links are affected. A full assessment of the flash butt welding machine is to be carried out, together with assessment of the condition of the bar ends prior to welding.
  - (i) Re-test requirements for tensile tests are to be in accordance with **Pt 2, Ch 1, 109.** of the Rules. Failure to meet the specified requirements of either or both additional tests will result in rejection of the sampling length of chain represented and (b) shall apply.
  - (j) Re-test requirements for Charpy impact tests are to be in accordance with **Pt 2, Ch 1, 109.** of the Rules. Failure to meet the requirements will result in rejection of the sam-

- pling length represented and (b) shall apply.
- (G) Marking
- (a) The chain shall be marked at the following places:
    - At each end.
    - At intervals not exceeding 100 m.
    - On connecting common links.
    - On links next to shackles or connecting common links.
  - (b) All marked links shall be stated on the certificate, and the marking shall make it possible to recognize leading and tail end of the chain. In addition to the above required marking, the first and last common link of each individual charge used in the continuous length shall be traceable and adequately marked.  
The marking shall be permanent and legible throughout the expected lifetime of the chain.
  - (c) The chain shall be marked on the studs as follows:
    - Chain grade (e.g. KR-R3, KR-R3S, KR-R4, KR-R4S and KR-R5 for stud link, KR-R3-SL, KR-R3S-SL, KR-R4-SL, KR-R4S-SL and KR-R5-SL for studless)
    - Certificate No.
    - Society's stamp
  - (d) The Certificate number may be exchanged against an abbreviation or equivalent. If so, this shall be stated in the certificate.
  - (e) The chain certificate shall contain information on number and location of connecting common links. The certificate number and replacement link number may be exchanged against an abbreviation or equivalent. If so, this shall be stated in the certificate.
- (H) Documentation
- (a) A complete Chain Inspection and Testing Report in booklet form shall be provided by the chain manufacturer for each continuous chain length. This booklet shall include all dimensional checks, test and inspection reports, NDT reports, process records, photographs as well as any nonconformity, corrective action and repair work.
  - (b) Individual certificates are to be issued for each continuous single length of chain.
  - (c) All accompanying documents, appendices and reports shall carry reference to the original certificate number.
  - (d) The manufacturer will be responsible for storing, in a safe and retrievable manner, all documentation produced for a period of at least 10 years.
- (5) Testing and inspection of accessories
- (A) General
- (a) This Sub-paragraph applies to but is not limited to mooring equipment accessories such as detachable connecting links (shackles), detachable connecting plates (triplates), end shackles, swivels and swivel shackles, and subsea connectors.
  - (b) All accessories are to be subjected to proof load tests, sample break load tests and sample mechanical tests after final heat treatment in the presence of a Surveyor. Where the manufacturer has a procedure to record proof loads and the Surveyor is satisfied with the adequacy of the recording system, he need not witness all proof load tests. The Surveyor is to satisfy himself that the testing machines are calibrated and maintained in a satisfactory condition. Prior to testing and inspection the chain accessories are to be free from scale, paint or other coating.
  - (c) For accessory production a Manufacturing Procedure Specification (MPS) is to be submitted to the Classification Society that details all critical aspects of accessory production, casting, forging, heat treating (including arrangement and spacing of components in the heat treatment furnaces), quenching, mechanical testing, proof and break loading and NDE.
- (B) Proof and break load tests
- (a) All accessories are to be subjected to the proof load specified for the corresponding stud link chain.
  - (b) Chain accessories are to be tested at the break load prescribed for the grade and size of chain for which they are intended. At least one accessory out of every batch or every 25 accessories, whichever is less, is to be tested.
    - (i) For individually produced, individually heat treated, accessories or accessories produced in small batches (less than 5), alternative testing will be subject to special consideration. Alternative testing is to be approved by the Classification Society and

- the following additional conditions may apply.
- ① Alternative testing is described in a written procedure and manufacturing procedure specification (MPS).
  - ② A finite element analysis is provided at the break load and demonstrates that the accessory has a safety margin over and above the break load of the chain.
  - ③ Strain age testing (as per approved procedure by the Society) is carried out on the material grade produced to the same parameters at the time of qualification.
  - ④ If an accessory is of a large size that will make heat treating in batches unfeasible or has a unique design, strain gauges are to be applied during the proof and break load tests during initial qualification and during production. The strain gauge results from production are to be comparable with the results from qualification.
- (c) A batch is defined as accessories that originate from the same heat treatment charge and the same heat of steel. Reference **Par 3** and **Par 4** of **Pt 2, Annex 2-9** of the Guidance.
- (d) The accessories which have been subjected to the break load test are to be destroyed and not used as part of an outfit, with the exceptions given in (e).
- (e) Where the accessories are of increased dimension or alternatively a material with higher strength characteristics is used, they may be included in the outfit at the discretion of the Society, provided that;
- (i) the accessories are successfully tested at the prescribed breaking load appropriate to the chain for which they are intended, and
  - (ii) it is verified by procedure tests that such accessories are so designed that the breaking strength is not less than 1.4 times the prescribed breaking load of the chain for which they are intended.
  - (iii) strain age properties have been carried out on the material grade produced to the same parameters.
  - (iv) strain gauges are to be applied during the break load test in the high stress locations to monitor that the strains stay within allowable limits.
- (C) Dimensions and dimensional tolerances
- (a) At least one accessory (of the same type, size and nominal strength) out of 25 is to be checked for dimensions after proof load testing. The manufacturer is to provide a statement indicating compliance with the purchaser's requirements.
  - (b) The following tolerances are applicable to accessories:
    - (i) Nominal diameter: + 5 percent, - 0 percent
    - (ii) Other dimensions:  $\pm$  2.5 percentThese tolerances do not apply to machined surfaces.
- (D) Mechanical tests
- (a) Accessories are to be subjected to mechanical testing as described in **Par 3** and **Par 4** of **Pt 2, Annex 2-9** of the Guidance. Mechanical tests are to be taken from proof loaded full size accessories that have been heat treated with the production accessories they represent. At least one accessory out of every batch or every 25 accessories, whichever is less, is to be tested. Hardness tests are to be carried out on finished accessories. The frequency and locations are to be agreed with the Society. The recorded values are for information only and used as an additional check to verify that the heat treatment process has been stable during the accessory production. The use of separate representative coupons is not permitted except as indicated in (e) below.
  - (b) Test location of forged shackles. Forged shackle bodies and forged Kenter shackles are to have a set of three impact tests and a tensile test taken from the crown of the shackle. Tensile tests on smaller diameter shackles can be taken from the straight part of the shackle, where the geometry does not permit a tensile specimen from the crown. The tensile properties and impact values are to meet the requirements of **Table 4.8.4** of the Guidance in the locations specified in **Fig 1** of **Pt 2, Annex 2-9** of the Guidance, with the Charpy pieces on the outside radius.
  - (c) The locations of mechanical tests of cast shackles and cast Kenter shackles can be taken from the straight part of the accessory. The tensile properties and impact values are to meet the requirements of **Table 4.8.4** of the Guidance in the locations specified in

Fig 1 of Pt 2, Annex 2-9 of the Guidance.

- (d) The locations of mechanical tests of other accessories with complex geometries are to be agreed with the Society.  
For non-circular sections,  $1/4t$  (thickness) from the surface is considered appropriate.  
Rolled plates are to be tested to the Standard to which they are produced.
- (e) For individually produced (heat treated) accessories or accessories produced in small batches, (less than 5), alternative testing can be proposed to the Society. Each proposal for alternative testing is to be detailed by the manufacturer in a written procedure and submitted to the Society, and the following additional conditions may apply:
  - (i) If separately forged or cast coupons are used, they are to have a cross-section and, for forged coupon, a reduction ratio similar to that of the accessories represented, and are to be heat treated in the same furnace and quenched in the same tank at the same time, as the actual forgings or castings. Thermocouples are to be attached to the coupon and to the accessories.
  - (ii) If separately forged or cast coupons are agreed, it is to be verified by procedure test that coupon properties are representative of accessory properties.
- (f) A batch is defined as accessories that originate from the same heat treatment charge and the same heat of steel. Reference Par 3 and Par 4 of Pt 2, Annex 2-9 of the Guidance.
- (g) Mechanical tests of pins are to be taken as per Fig 1 of Pt 2, Annex 2-9 of the Guidance from the mid length of a sacrificial pin of the same diameter as the final pin. For oval pins the diameter taken is to represent the smaller dimension. Mechanical tests may be taken from an extended pin of the same diameter as the final pin that incorporates a test prolongation and a heat treatment buffer prolongation, where equivalence with mid length test values have been established. The length of the buffer is to be at least equal to 1 pin diameter dimension which is removed after the heat treatment cycle is finished. The test coupon can then be removed from the pin. The buffer and test are to come from the same end of the pin as per Fig 4.8.13 of the Guidance.

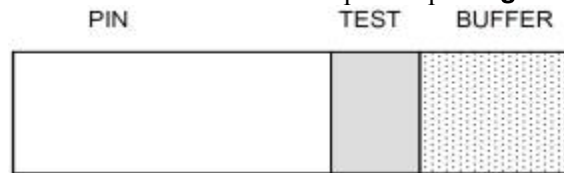


Fig 4.8.13 Buffer and test piece location

- (E) Non-destructive examination after proof load testing
  - (a) All chain accessories are to be subjected to a close visual examination. Special attention is to be paid to machined surfaces and high stress regions. Prior to inspection, chain accessories are to have a suitably prepared surface as per the applied NDE testing standard. All non-machined surfaces are to be sand or shot blast to permit a thorough examination. Where applicable, accessories shall be dismantled for inspection of internal surfaces. All accessories are to be checked by magnetic particles or dye penetrant. UT of accessories may be required by the Society. The acceptance /rejection criteria of UT established for the design is to be met.
  - (b) Testing is to be performed in accordance with a recognized Standard, such as those indicated below, or equivalent. The procedures, together with acceptance/rejection criteria are to be submitted to the Society for review.  
Manufacturers shall prepare written procedures for NDE. NDE personnel shall be qualified and certified according to ISO 9712, ACCP or equivalent. Personnel qualification to an employer or responsible agency based qualification scheme as SNT-TC-1A may be accepted if the employer's written practice is reviewed and found acceptable and the Level III is ASNT Level III, ISO 9712 Level III or ACCP Professional Level III and certified in the applicable method. NDE operators shall be qualified to at least level II.

Magnetic particle testing (MT) of forgings:

- EN 10228-1, ASTM A275, using wet continuous magnetization technique or equivalent standards such as ISO 4986, IACS Rec 69

Ultrasonic testing (UT) of forgings:  
- EN 10228-3, ASTM A388, ISO 13588

Magnetic particle testing (MT) of castings:  
- ASTM E709, using wet continuous magnetization technique

Ultrasonic testing (UT) of castings:  
- ASTM A609, ISO 13588

All surfaces shall be magnetic particle tested (MT). Testing shall be performed in accordance with standards referenced using the fluorescent technique. As a minimum surfaces shall be free from:

- relevant linear indications exceeding 1.6 mm in transverse direction
- relevant linear indications exceeding 3.2 mm in longitudinal direction
- relevant non-linear indications exceeding 4.8 mm.

When required by the Society, ultrasonic testing is to be carried out on 100% of cast or forged accessories. The acceptance/rejection criteria established for the design is to be met.

- (c) The manufacturer is to provide a statement that non destructive examination has been carried out with satisfactory results. This statement should include a brief reference to the techniques and to the operator's qualification.
- (d) Weld repairs of finished accessories are not permitted.

(F) Test failures

- (a) In the event of a failure of any test the entire batch represented is to be rejected unless the cause of failure has been determined and it can be demonstrated to the Surveyor's satisfaction that the condition causing the failure is not present in any of the remaining accessories.

(G) Marking

- (a) Each accessory is to be marked as follows:
  - Chain grade (e.g. KR-R3, KR-R3S, KR-R4, KR-R4S and KR-R5 for stud link, KR-R3-SL, KR-R3S-SL, KR-R4-SL, KR-R4S-SL and KR-R5-SL for studless)
- (b) The Certificate number may be exchanged against an abbreviation or equivalent. If so, this shall be stated in the certificate.

(H) Documentation

- (a) A complete Inspection and Testing Report in booklet form shall be provided by the manufacturer for each order. This booklet shall include all dimensional checks, test and inspection reports, NDT reports, process records and example photographs of components positioned in furnaces, as well as any nonconformity, corrective action and repair work.
- (b) Each type of accessory shall be covered by separate certificates.
- (c) All accompanying documents, appendices and reports shall carry reference to the original certificate number.
- (d) The manufacturer will be responsible for storing, in a safe and retrievable manner, all documentation produced for a period of at least 10 years.

3. "Chafing Chain for Single Point Mooring arrangements" specified in **Pt 4, Ch 8, 401. 2** of the Rules are as follows. (2017)

(1) Scope

These requirements apply to short lengths (approximately 8 m) of 76 mm diameter chain to be connected to hawsers for the tethering of oil carriers to single point moorings, FPSO's and similar uses.

(2) Approval of Manufacturing

The chafing chain is to be manufactured by works approved by the Society according to **Ch 2, 1023. of Guidance for Approval of Manufacturing Process and Type Approval, Etc..**

(3) Materials

The materials used for the manufacture of the chafing chain are to satisfy the requirements of **Pt 2, Annex 2-9** of the Guidance.

(4) Design, manufacturing, testing and certification

- (A) The chafing chain is to be designed, manufactured, tested and certified in accordance with the requirements specified in **2 (3), (4) and (5)**, except that batch heat treatment is permitted.
- (B) The arrangement of the end connections is to be of an approved type.
- (C) The common link is to be of the stud link type - Grade R3 or R4.
- (D) The chafing chain is to be capable of withstanding the breaking test loads of 4884 kN (Grade R3) and 6001 kN (Grade R4). See Note 1.
- (E) The chain lengths shall be proof load tested in accordance with **2 (4) (B)**. The test load for Grade R3 is 3242 kN and for Grade R4 is 4731 kN.

Note 1: Documented evidence of satisfactory testing of similar diameter mooring chain in the prior 6 month period may be used in lieu of break testing subject to agreement with the society.

Note 2: The requirements herein are also applicable to other diameter chafing chains, such as 84 mm and 96 mm, subject to compliance with the proof and break load requirements specified for the chain grade and diameters in **Table 4.8.5** of the Guidance.

#### **409. Dimensions and forms**

1. In **Pt 4, Ch 8, 409. 1** of the Rules, when manufacturer would make chains different from standard dimensions, the dimension tables are to be approved by the Society except the case where the dimensions comply with KS or ISO. **[See Rule]**
2. For anchor chain cables for large anchor specified in **Pt 4, Ch 8, 203. 1** of the Rules, the length of the shackle and accessories may be included in one length of chain.

#### **412. Breaking test of chains [See Rule]**

1. The omissions of breaking test of chains due to the shortage of capacity of testing machine specified in **Pt 4, Ch 8, 412. 2** of the Rules, is to be in accordance with the following requirements in (1) to (3).
  - (1) Chains are to be comply with the requirements as follows.
    - (A) Chains are to be Grade 2 or Grade 3 chain.
    - (B) Breaking loads specified in **Table 4.8.7** of the Rules are to be above 6000 kN.
    - (C) Chains are to be heat treated.
    - (D) Breaking test had been demonstrated at approval test for manufacturing process for the nominal diameter or more.
    - (E) For welded chains specified in **Pt 4, Ch 8, 413.** of the Rules is to pass the mechanical test of chain link.
  - (2) Following tests are to be carried out as an alternative test. Manufacturers are to obtain approval of the concrete testing plan by the Society in advance. The test is able to confirm the strength of welded part for welded chain.
    - (A) Non-destructive inspection
    - (B) Marco-structure inspection
    - (C) Bend test
    - (D) Tensile test
    - (E) For Grade 3 chain impact test may be required for reference.
  - (3) Where the test had been performed as specified in (2) without breaking test, "Alternative breaking test has been applied" is indicated in the certificate.

#### **413. Test and inspection of accessories [See Rule]**

In **413. 2 (4)** of the Rules, the term "subject to the approval by the Society" means the case where the result of test and inspection of **413. 2 (4) (A) to (C)** are accepted as following.

- (A) In case of the result of breaking load test of the approval testing of parts of the same design are accepted.
- (B) In case of accepted by a criterion specified in **Ch 2, 1013. Table 2.10.2 of the Guidance for Approval of Manufacturing Process and Type Approval, Etc.**

(C) In case of accepted by a non-destructive criterion specified in Pt 2, Annex 2-2 and Annex 2-7 of the Rules.

## Section 5 Steel Wire Ropes

### 506. Rope test

- The values not included in breaking loads of steel wire ropes in Table 4.8.13 specified in Pt 4, Ch 8, 506. of the Rules are to be as follows.

Breaking loads of rope = area coefficient × strand efficiency coefficient × tensile strength(KN/mm<sup>2</sup>) × (diameter of rope)<sup>2</sup>

Area coefficient and strand efficiency coefficient according to composition mark of steel wire ropes are to be as follows.

Composition mark of steel wire ropes	Area coefficient	Strand efficiency coefficient
6 x 7	0.399	0.90
6 x 12	0.252	0.88
6 x 19	0.397	0.86
6 x 24	0.358	0.87
6 x 30	0.317	0.88
6 x 37	0.395	0.85
6 x WS(36)	0.429	0.80

## Section 7 Hatch Tarpaulins

### 701. Application [See Rule]

Test and inspection of hatch tarpaulins made of synthetic materials is in accordance with "Regulations for Type Approval Test and Inspection of Ship and Ship's Articles"

## Section 9 Rectangular Windows

### 906. Dispensation with tests [See Rule]

In 906. of the Rules, the "appropriate certificates accepted by the Society" means the certificates issued by any Society which is subject to verification of compliance with QSCS(Quality System Certification Scheme) of IACS and the relevant flag state or MED certificates. ↓

---

---

# CHAPTER 9 STRENGTH AND SECURING OF SMALL HATCHES, FITTINGS AND EQUIPMENT ON THE FORE DECK

## Section 2

### Strength and Securing of Small Hatches on the Exposed Fore Deck

#### 201. General [See Rule]

In application of **201. 3** of the Rules, securing devices of hatches designed for emergency escape are to be of a quick-acting type(e.g., one action wheel handles are provided as central locking devices for latching/unlatching of hatch cover)operable from both sides of the hatch cover.

#### 202. Strength [See Rule]

In **202. 3** of the Rules, the term "to be in accordance with the requirement specified by the Society" means the case where the thickness of hatch cover not be less than 6.0mm. ⚓

# CHAPTER 10 SHIPBOARD EQUIPMENT, FITTINGS AND SUPPORTING HULL STRUCTURES ASSOCIATED WITH TOWING AND MOORING

## Section 1 Definitions and Scope of Application

### 101. Application [See Rule]

In application of Pt 4, Ch 10, 101. 7 of the Rules, the details are as follows. (2019)

#### 1. General

##### (1) Application

This instruction, in case of survey requested by an applicants (shipowner's, shipyard's or manufacturer's, hereafter referred to as "applicants"), is to be applied to mooring equipment of SPM using standard equipment complying with the recommendations of the Oil Companies International Marine Forum (hereafter referred to as "OCIMF") fitted onboard ships such as oil tankers (hereafter referred to as "ships"), the delivery of which is after 1 January 2009.

##### (2) General arrangement of mooring equipment of SPM

(A) The components of the ship's equipment required for mooring equipment of SPM are the chain stopper, fairlead, pedestal roller, winch or capstan. (See Fig 4.10.1)

However, pedestal roller may not be installed according to arrangement of winch/capstan.

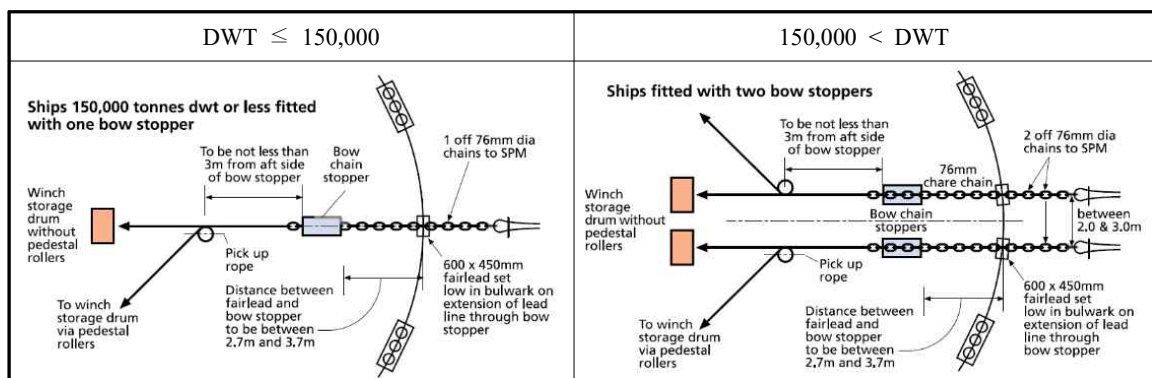


Fig 4.10.1 General arrangement of mooring equipment of SPM

(B) For mooring at SPM terminals, ships are to be provided forward with equipment to haul a standardized chafing chain of 76 mm in diameter connection to structure of single point mooring or end of the hawser wire of single buoy mooring terminals.

(C) When the chafing chain is carried on board the ship as a component for mooring equipment of SPM, chafing chain is comply with the requirements in Pt 4, Ch 8, 401. 3 of the Guidance.

#### 2. Design and specification of material

##### (1) Forward chain stoppers

(A) Chain stopper is to secured the chafing chain as a strong point. The number of chain stoppers and their safe working loads (SWL) are defined in Table 4.10.1.

Table 4.10.1 Number and SWL of chain stoppers

Deadweight (ton)	Chain stoppers	
	Number	Safe working load(SWL) (ton)
DWT ≤ 100,000	1	200
100,000 < DWT ≤ 150,000	1	250
150,000 < DWT	2	350

- (B) Chain stoppers are to be capable of securing the 76 mm common stud links of the chafing chain when the stopping device is in the closed position, and capable of passing freely the chafing chain and its associated fittings when the stopping device is in the open position.
- (C) Chain stoppers may be of the hinged bar or pawl type or of other equivalent design.
- (D) The stopping device of the chain stopper is to be arranged, when in the closed position, to prevent it from gradually working to the open position, which would release the chafing chain and allow it to pay out. Stopping devices are to be easy and safe to operate and, in the open position, are to be properly secured.
- (E) Chain stoppers are to be located between 2.7 m and 3.7 m inward of the hull from the bow fairlead. Fairlead and pedestal roller are to be located in line with each other.
- (F) Stopper supporting structures are to be trimmed to compensate for any camber and/or sheer of the deck. The leading edge of the stopper base plate is to be faired to allow for the unimpeded entry of the chafing chain into the stopper.
- (G) Where the chain stopper is bolted to a seating welded to the deck, the bolts are to be satisfied with the following strength criteria. However, in such condition, efficient thrust chocks capable of withstanding a horizontal force equal to 2.0 times the required working strength are to be installed.

$$\sigma_{VM} \leq \sigma_y$$

Where,

$\sigma_{VM}$  : The equivalent stress in the equipment components(bolts, etc.) induced by the loads.

$\sigma_y$  : Permissible stress, to be taken, in N/mm<sup>2</sup>, (=  $R_{eH}$ ) (2019)

$R_{eH}$  : Minimum yield stress, in N/mm<sup>2</sup>, of the material

- (H) The steel grade of bolts is to be not less than grade 8.8 as defined by **KS B ISO898-1** (Grade 10.9 is recommended). Bolts are to be pre-stressed in compliance with appropriate standards and tightening is to be suitably checked.
- (I) The chain stopper is to be made of rolled steel, steel forging or steel casting complying with the requirements of **Pt 2, Ch 1** of the Rules.  
However, use of spheroidal graphite iron casting may be accepted for the main component of the chain stopper provided that:
- the component concerned is not to be a welded part
  - the spheroidal graphite iron casting is of ferritic structure with an elongation not less than 12%
  - the yield stress at 0.2% proof load is measured and surveyed
  - the internal structure of the component is inspected by means of non-destructive examinations
- (J) The material used for the stopping device (pawl or hinged bar) of chain stoppers is to have mechanical properties similar to Grade R3 chain cable.
- (2) Fairleads
- (A) One fairlead is to be fitted for each chain stopper.
- (B) For ships of over 150,000 ton DWT, two fairleads are required and the fairleads are to be spaced 2.0 m or more center to center apart, if practicable, and in no case more than 3.0 m apart. For ships of 150,000 ton DWT or less, only one fairlead is to be fitted on the centerline.
- (C) Fairleads are normally of a closed type such as Panama chocks and are to have an opening

large enough to pass the largest portion of the chafing chain, pick-up rope and associated fittings. For this purpose, the inner dimensions of the bow fairlead opening are to be at least 600 mm in width and 450 mm in height.

- (D) Fairleads are to be oval or round in shape. The lips of the fairleads are to be suitably faired in order to prevent the chafing chain from fouling on the lower lip when heaving inboard. The bending ratio (bearing surface diameter of the fairlead to chafing chain diameter) is to be not less than 7 to 1.
- (E) Fairleads are to be located as close as possible to the deck and, in any case, to be in such a position that the chafing chain is approximately parallel to the deck when it is pulled between the chain stopper and the fairlead.
- (F) Fairleads are to be made of rolled steel, steel forging or steel casting complying with the requirements of **Pt 2, Ch 1** of the Rules.
- (3) Pedestal roller
  - (A) Pedestal rollers are to be positioned to enable a direct pull to be achieved on the continuation of the direct lead line between the fairlead and chain stopper. They are to be fitted not less than 3.0 m behind the chain stopper.
  - (B) Pedestal rollers are to be capable of withstanding a horizontal force equal to the greater of the following values. Stresses generated by this horizontal force are to comply with the strength criteria indicated in **Par 2 (1) (G)**.
    - (a) 22.5 ton
    - (b) the resultant force due to an assumed pull of 22.5 ton in the pick-up rope
  - (C) It is recommended that the pedestal roller should have a diameter not less than 7 times the diameter of the pick-up rope. Where the diameter of the pick-up rope is unknown, the roller diameter should be at least 400 mm.
- (4) Winches or capstans
  - (A) Winches or capstans used to handle the mooring gear are to be capable of heaving inboard a load of at least 15 ton. For this purpose winches or capstans are to be capable of exerting a continuous duty pull of not less than 15 ton and withstanding a braking pull of not less than 22.5 ton.
  - (B) If a winch storage drum is used to stow the pick-up rope, it is to be of sufficient size to accommodate 150 m of rope of 80 mm diameter.

### 3. Type approval

The prototype testing of mooring equipment of SPM is to be in accordance with **Ch 3, Sec 7-2**. in "**Guidance for Approval of Manufacturing Process and Type Approval, Etc**".

### 4. Certificate Etc.

- (1) Issuing, valid term and renewal for the approval certificate are to be complied with **Ch 3, Sec 1** in "**Guidance for Approval of Manufacturing Process and Type Approval, Etc**".
- (2) Some components of mooring equipment of SPM may be also used for the bow emergency towing arrangements provided that the requirements of instruction are to be complied with and type approval of bow emergency towing arrangement complied with **Ch 3, Sec 7-1**. in "**Guidance for Approval of Manufacturing Process and Type Approval, Etc**".

### 5. Component's inspection of mooring equipment of SPM

Where components of mooring equipment of SPM have undergone the type approval of this Society and satisfactorily passed the tests and inspections required as followings, the certificate will be issued when applicants request the inspection of components.

- (1) Chain stoppers used to mooring equipment of SPM are according to the followings.
  - (A) The materials are to comply with the requirements in **Pt 2, Ch 1** of the Rules and dimensions are to comply with an approved drawings.
  - (B) Performance of chain stopper is to comply with the requirements in **101. 2 (1)**.
  - (C) Chain stoppers are to be wholly examined by ultrasonic test in principle, but, if impracticable, may be examined by effective non-destructive test such as magnetic particle test.
  - (D) Where chain stoppers have satisfactorily passed the tests and inspections required in this Society, safe working load and identification numbers are to be marked permanently.
- (2) Fairleads used to mooring equipment of SPM are to be in accordance with the following requirements.

- (A) The materials are to comply with the requirements in **Pt 2, Ch 1** of the Rules and dimensions are to comply with an approved drawings.
  - (B) Performance of fairleads is to comply with the requirements in **101. 2 (2)**.
  - (C) Fairleads are to be wholly examined by ultrasonic test in principle, but, if impracticable, may be examined by effective non-destructive test such as magnetic particle test.
- (3) Pedestal roller and winches or capstans used to mooring equipment of SPM are to comply with the requirements in **101. 2 (3), (4)** and to be verified by means of certificate/report of inspection issued by manufacturer.

## 6. Installation inspection of mooring equipment of SPM on board

Where mooring equipment of SPM type approved by this Society is requested for the installation inspection onboard by ship owner or by shipyard, the equipment is to be satisfactorily passed drawing approval and the tests as followings, the fitness certificate including supporting hull structure is to be issued.

### (1) Documentation

Prior to installation of the mooring equipment of SPM on a ship, the applicants are to submit the three copies of the following drawings and data for approval and information.

#### (A) Documentation for approval

- (a) General layout of the forecastle arrangements and mooring at single point moorings
- (b) Construction drawing of the bow chain stoppers, fairleads and pedestal roller, together with material specifications and relevant calculations
- (c) Drawings and relevant calculations of the local ship structures supporting the loads applied to chain stoppers, fairleads, pedestals roller and winches or capstans

#### (B) Informations

- (a) Specifications of winches or capstans giving the continuous duty pull and brake holding force
- (b) Deadweight(ton) of the ship at summer load line
- (c) Certificate and Type test record

### (2) Design and material requirements

Design and material requirements are to comply with the requirements in **Par 2**.

### (3) Supporting hull structures

- (A) General arrangement of chain stopper and fairlead is comply with **Fig 4.10.1** and **Fig 4.10.2**
- (B) The bulwark plating and stays are to be suitably reinforced in the region of the fairleads.
- (C) Deck structures in way of bow chain stoppers, including deck seatings and deck connections, are to be suitably reinforced to resist a horizontal load equal to 2 times the required safe working load and, in such condition, to meet the strength criteria(based on net thickness) specified in **Par 2 (1) (G)**. (2019)
- (D) Minimum thickness of the deck structures in way of the strongpoint and in way of fairlead as well as the deck connections is defined local structure strength calculation and to be at least 15 mm.
- (E) For deck bolted chain stoppers, reinforcements are to comply with the requirements in **2 (1) (G)** and **(H)**.
- (F) The deck structures in way of the pedestal roller and in way of winches or capstans as well as the deck connections are to be reinforced to withstand, respectively, the horizontal force defined in **Par 2 (3) (B)** or the braking pull defined in **Par 2 (4) (A)** and to meet the strength criteria specified in **Par 2 (1) (G)**.

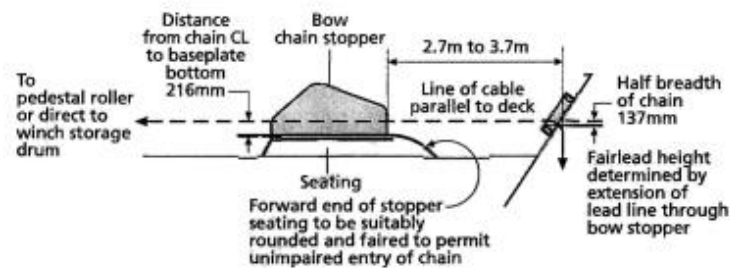


Fig 4.10.2 General arrangement of chain stopper and fairlead

- (4) Installation inspection on a ship
- (A) Components to be installed and inspected including support structure in accordance with an approved arrangement by this Society and components are to have no permanent deformation provided that proof test loads are equivalent to the required safe working load at least 1 minute as given **Table 4.10.1**. However, load test may be exempted in the following cases:
- (a) where mooring equipment of SPM with type approved by this Society, inspection has been approved in accordance with the requirements in **Par 5**.
  - (b) where mooring equipment of SPM without type approved by this Society, strength calculation sheets provided that 2 times the required safety factor should be submitted and approved by this Society and inspection has been approved in accordance with the requirements in **Par 5**, provided that proof test loads equivalent to safe working load.
- (B) Supporting hull structures are to comply with the requirements in **Par 6 (3)**.
- (C) Main welds of the chain stoppers with the hull structure are to be 100% inspected by means of non-destructive examinations.
- (D) Onboard status of an instruction manual and approved drawings are to be confirmed.

## Section 2 Towing and Mooring

### 206. Survey after construction [See Rule]

The condition of deck fittings, their pedestals, if any, and the hull structures in the vicinity of the fittings are to comply with regulations specified in **Pt 1, Ch 2, 202**, of the Rules. ↓

# CHAPTER 11 ACCESS TO AND WITHIN SPACES IN, AND FORWARD OF, THE CARGO AREA OF OIL TANKERS AND BULK CARRIERS

## Section 1 General

### 101. Application [See Rule]

1. In application of **101. 1** of the Rules, the details are as follows.

- (1) The contents of Res. MSC.151/8(78) can be applied for ships which were keeling on and after 1 Jan. 2005 instead of Res. MSC.133/4(76).
- (2) Oil tankers:  
The regulation is only applicable to oil tankers having integral tanks for carriage of oil in bulk, which is contained in the definition of oil in Annex 1 of MARPOL 73/78. Independent oil tanks can be excluded. SOLAS Regulation II-1/3-6 is not normally applied to FPSO or FSO unless the Administration decides otherwise.

### 102. Means of access to cargo and other spaces [See Rule]

1. In application of **102. 1** of the Rules, the details are as follows.

Each space for which close-up inspection is not required such as fuel oil tanks and void spaces forward of cargo area, may be provided with a means of access necessary for overall survey intended to report on the overall conditions of the hull structure.

2. In application of **102. 2** of the Rules, the details are as follows.

- (1) Some possible alternative means of access are listed under **202. 9** of the Rules. Always subject to acceptance as equivalent by the Administration, alternative means such as an unmanned robot arm, ROV's and dirigibles with necessary equipment of the permanent means of access for overall and close-up inspections and thickness measurements of the deck head structure such as deck transverses and deck longitudinals of cargo oil tanks and ballast tanks, are to be capable of:
  - safe operation in ullage space in gas-free environment;
  - introduction into the place directly from a deck access.

3. In application of **102. 3** of the Rules, the details are as follows.

(1) Inspection

The MA arrangements, including portable equipment and attachments, are to be periodically inspected by the crew or competent inspectors as and when it is going to be used to confirm that the MAs remain in serviceable condition.

(2) Procedures

- (A) Any company authorised person using the MA shall assume the role of inspector and check for obvious damage prior to using the access arrangements. Whilst using the MA the inspector is to verify the condition of the sections used by close up examination of those sections and note any deterioration in the provisions. Should any damage or deterioration be found, the effect of such deterioration is to be assessed as to whether the damage or deterioration affects the safety for continued use of the access. Deterioration found that is considered to affect safe use is to be determined as "substantial damage" and measures are to be put in place to ensure that the affected section(s) are not to be further used prior effective repair.
- (B) Statutory survey of any space that contains MA shall include verification of the continued effectiveness of the MA in that space. Survey of the MA shall not be expected to exceed the scope and extent of the survey being undertaken. If the MA is found deficient the scope of survey should be extended if this is considered appropriate.
- (C) Records of all inspections are to be established based on the requirements detailed in the ships Safety Management System. The records are to be readily available to persons using the MAs and a copy attached to the MA Manual. The latest record for the portion of the MA inspected should include as a minimum the date of the inspection, the name and title of the inspector, a confirmation signature, the sections of MA inspected, verification of con-

tinued serviceable condition or details of any deterioration or substantial damage found. A file of permits issued should be maintained for verification.

### 103. Safe access to cargo holds, cargo tanks, ballast tanks and other spaces [See Rule]

1. In application of **103. 1** of the Rules, the details are as follows. (2017)

- (1) Access to a double side skin space of bulk carriers may be either from a topside tank or double bottom tank or from both.
- (2) The wording "not intended for the carriage of oil or hazardous materials" applies only to "similar compartments", i.e. safe access can be through a pump-room, deep cofferdam, pipe tunnel, cargo hold or double hull space.

2. In application of **103. 2** of the Rules, the details are as follows.

A cargo oil tank of less than 35 m length without a swash bulkhead requires only one access hatch.

Where rafting is indicated in the ship structures access manual as the means to gain ready access to the under deck structure, the term "similar obstructions" referred to in the regulation includes internal structures (e.g., webs >1.5 m deep) which restrict the ability to raft (at the maximum water level needed for rafting of under deck structure) directly to the nearest access ladder and hatchway to deck. When rafts or boats alone, as an alternative means of access, are allowed under the conditions specified in the ESP Code, as amended, permanent means of access are to be provided to allow safe entry and exit. This means:

- (1) access direct from the deck via a vertical ladder and small platform fitted approximately 2 m below the deck in each bay; or
- (2) access to deck from a longitudinal permanent platform having ladders to deck in each end of the tank. The platform shall, for the full length of the tank, be arranged in level with, or above, the maximum water level needed for rafting of under deck structure. For this purpose, the ullage corresponding to the maximum water level is to be assumed not more than 3 m from the deck plate measured at the midspan of deck transverses and in the middle length of the tank. (See Figure below). A permanent means of access from the longitudinal permanent platform to the water level indicated above is to be fitted in each bay (e.g., permanent rungs on one of the deck webs inboard of the longitudinal permanent platform).

### 104. Ship structure access manual [See Rule]

1. In application of **104. 1** of the Rules, the details are as follows.

Access manual should address spaces listed in paragraph 3 of SOLAS II-1/3-6.

As a minimum the English version should be provided

The ship structure access manual is to contain at least the following two parts:

Part 1: Plans, instructions and inventory required by paragraphs 4.1.1 to 4.1.7 of SOLAS II-1/3-6. This part is to be approved by the Administration or the organization recognised by the Administration

Part 2 : Form of record of inspections and maintenance, and change of inventory of portable equipment due to additions or replacement after construction. This part is to be approved for its form only at new building.

The following matters are to be addressed in the ship structure access manual:

- (1) The access manual should clearly cover scope as specified in the regulations for use by crews, surveyors and port state control officers.
- (2) Approval / re-approval procedure for the manual, i.e. any changes of the permanent, portable, movable or alternative means of access within the scope of the regulation and the Technical provisions are subject to review and approval by the Administration or by the organization recognised by the Administration.
- (3) Verification of MA is to be part of safety construction survey for continued effectiveness of the MA in that space which is subject to the statutory survey.

- (4) Inspection of MA by the crew and/or a competent inspector of the company as a part of regular inspection and maintenance.
- (5) Actions to be taken if MA is found unsafe to use.
- (6) In case of use of portable equipment plans showing the means of access within each space indicating from where and how each area in the space can be inspected;

2. In application of **104. 2** of the Rules, the details are as follows.

- (1) Critical structural areas are to be identified by advanced calculation techniques for structural strength and fatigue performance, if available, and feed back from the service history and design development of similar or sister ships.
- (2) Reference is to be made to the following publications for critical structural areas, where applicable:
  - Oil tankers: Guidance Manual for Tanker Structures by TSCF;
  - Bulk carriers: Bulk Carriers Guidelines for Surveys, Assessment and Repair of Hull Structure by IACS;
  - Oil tankers and bulk carriers: the ESP Code, as amended.

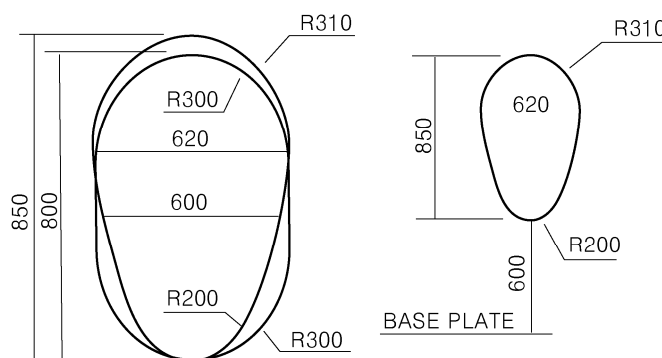
### 105. General technical specifications [See Rule]

1. In application of **105. 1** of the Rules, the details are as follows.

The minimum clear opening of 600 mm × 600 mm may have corner radii up to 100 mm maximum. The clear opening is specified in MSC/Circ.686 to keep the opening fit for passage of personnel wearing a breathing apparatus. In such a case where as a consequence of structural analysis of a given design the stress is to be reduced around the opening, it is considered appropriate to take measures to reduce the stress such as making the opening larger with increased radii, e.g. 600 mm × 800 mm with 300 mm radii, in which a clear opening of 600 mm × 600 mm with corner radii up to 100 mm maximum fits.

2. In application of **105. 2** of the Rules, the details are as follows.

- (1) The minimum clear opening of not less than 600 mm × 800 mm may also include an opening with corner radii of 300 mm. An opening of 600 mm in height × 800 mm in width may be accepted as access openings in vertical structures where it is not desirable to make large opening in the structural strength aspects, i.e. girders and floors in double bottom tanks.
- (2) Subject to verification of easy evacuation of injured person on a stretcher the vertical opening 850 mm × 620 mm with wider upper half than 600 mm, while the lower half may be less than 600 mm with the overall height not less than 850 mm is considered acceptable alternative to the traditional opening of 600 mm × 800 mm with corner radii of 300 mm.



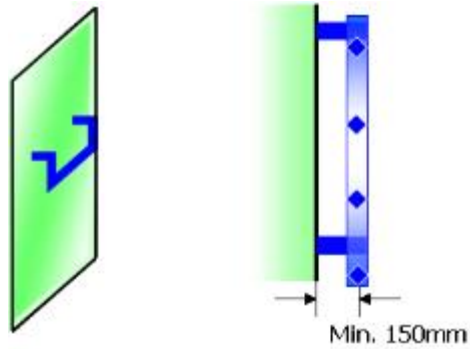
- (3) If a vertical opening is at a height of more than 600 mm steps and handgrips are to be provided. In such arrangements it should be demonstrated that an injured person can be easily evacuated.

## Section 2 Technical Provisions for Means of Access for Inspections

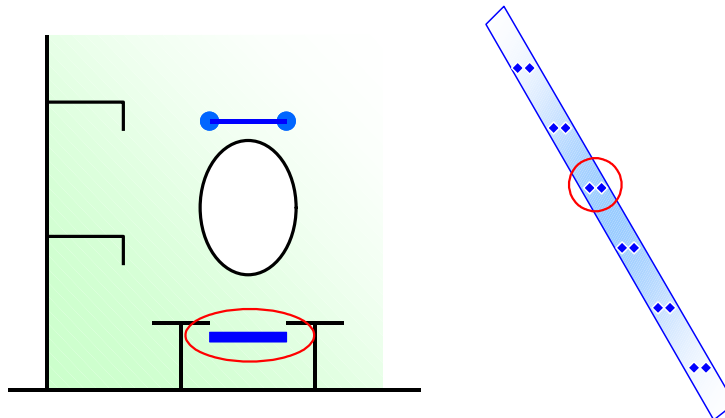
### 201. Definitions [See Rule]

1. In application of **201. 1** of the Rules, the details are as follows.

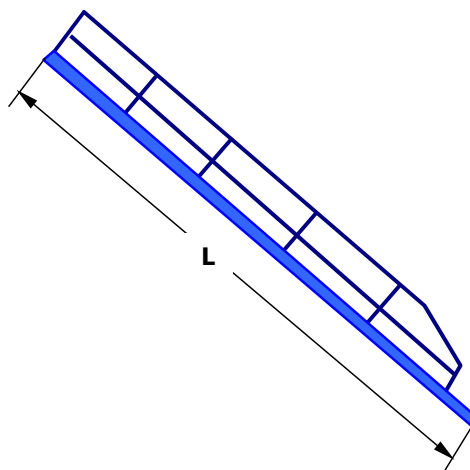
(1) rung



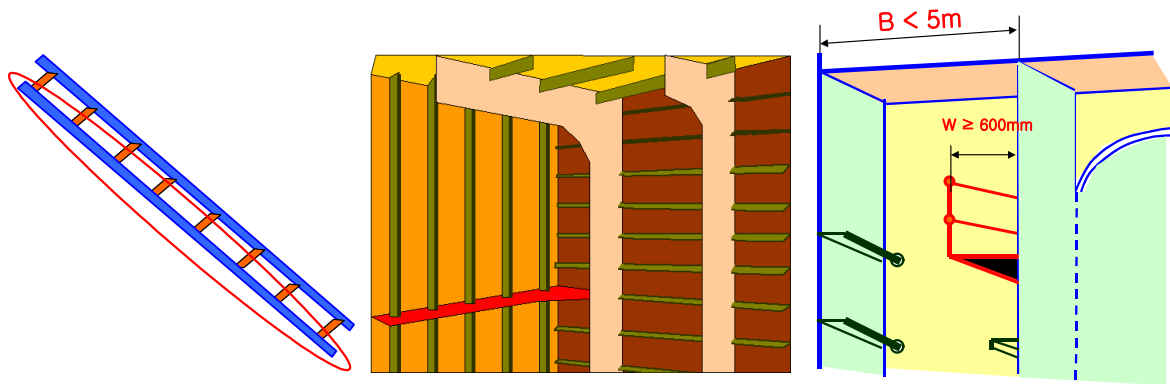
(2) tread



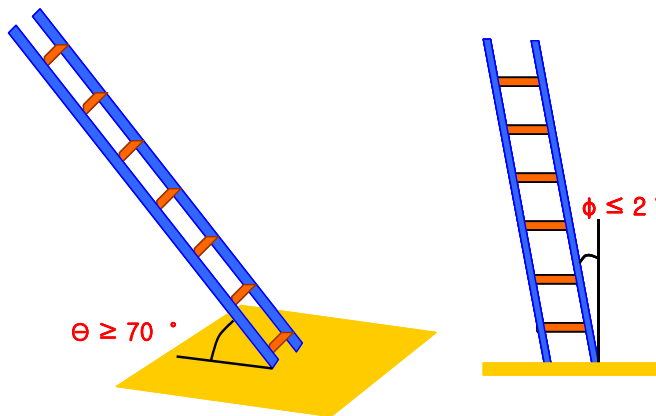
(3) flight of an inclined ladder



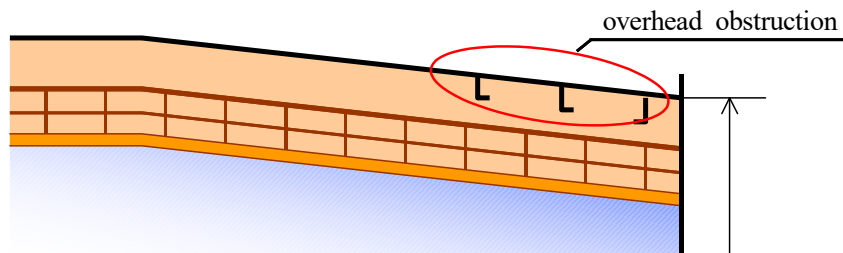
(4) stringer



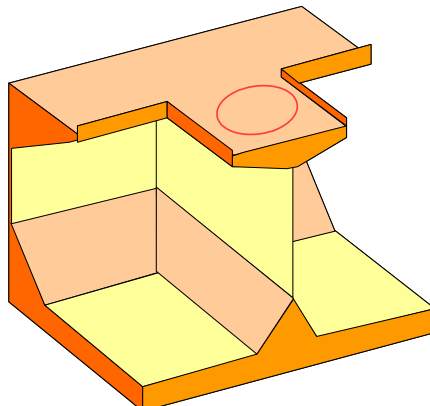
(5) vertical ladder



(6) overhead obstruction & (7) distance below deck head



(8) cross deck



**202. Technical provisions [See Rule]**

1. In application of **202. 1** of the Rules, the details are as follows.

The permanent means of access to a space can be credited for the permanent means of access for inspection.

2. In application of **202. 3** of the Rules, the details are as follows.

(1) Sloping structures are structures that are sloped by 5 or more degrees from horizontal plane when a ship is in upright position at even-keel.

(2) Guard rails are to be fitted on the open side and should be at least 1,000 mm in height. For stand alone passageways guard rails are to be fitted on both sides of these structures. Guardrail stanchions are to be attached to the PMA. The distance between the passageway and the intermediate bar and the distance between intermediate bar and the top rail shall not be more than 500 mm.

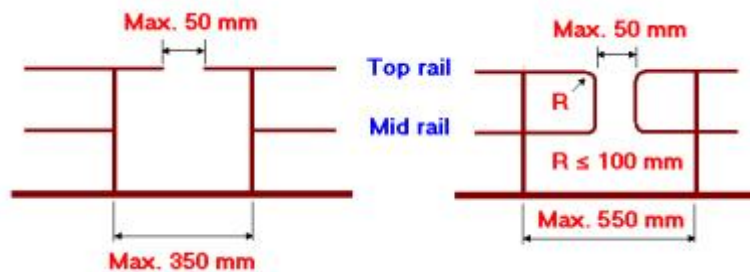
(3) Discontinuous top handrails are allowed, provided the gap does not exceed 50 mm.

The same maximum gap is to be considered between the top handrail and other structural members (i.e. bulkhead, web frame, etc.).

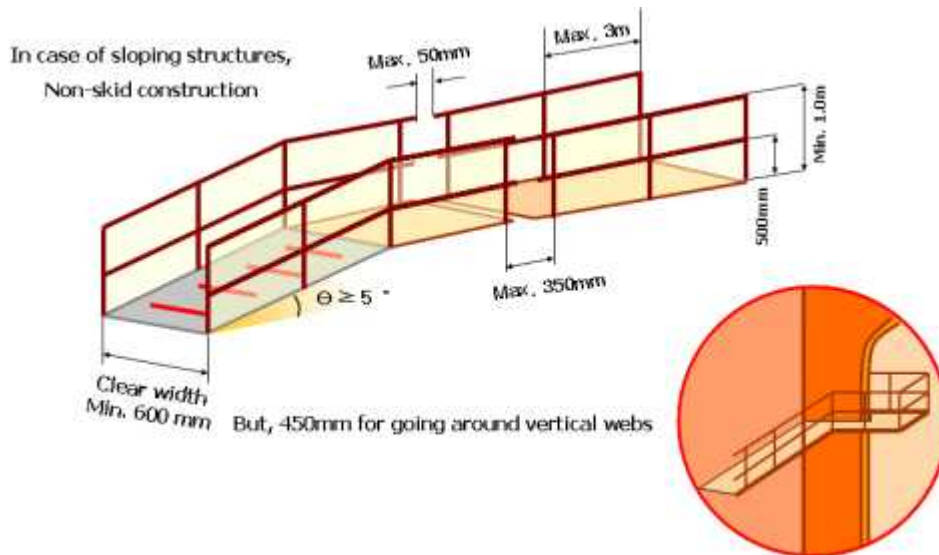
The maximum distance between the adjacent stanchions across the handrail gaps is to be 350 mm where the top and mid handrails are not connected together and 550 mm when they are connected together.

The maximum distance between the stanchion and other structural members is not to exceed 200 mm where the top and mid handrails are not connected together and 300 mm when they are connected together.

When the top and mid handrails are connected by a bent rail, the outside radius of the bent part is not to exceed 100 mm (see Figure below).

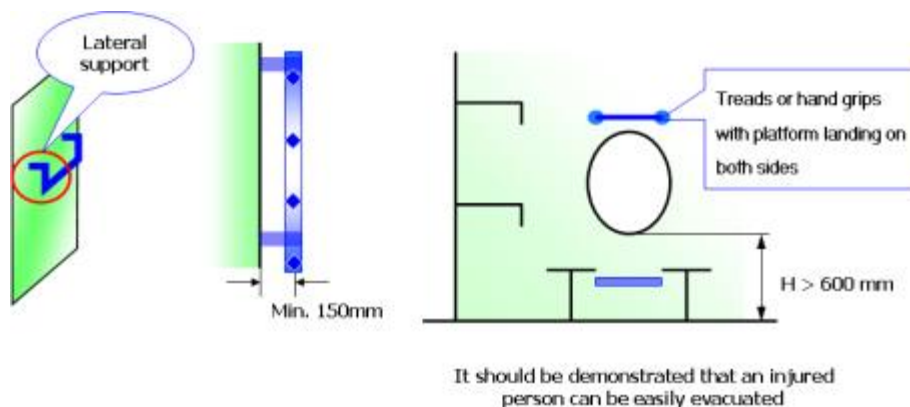


- (4) Non-skid construction is such that the surface on which personnel walks provides sufficient friction to the sole of boots even the surface is wet and covered with thin sediment.
- (5) “Substantial construction” is taken to refer to the as-designed strength as well as the residual strength during the service life of the vessel. Durability of passageways together with guard rails should be ensured by the initial corrosion protection and inspection and maintenance during services.
- (6) For guard rails, use of alternative materials such as GRP should be subject to compatibility with the liquid carried in the tank. Non-fire resistant materials should not be used for means of access to a space with a view to securing an escape route at a high temperature.
- (7) Requirements for resting platforms placed between ladders are equivalent to those applicable to elevated passageways.



3. In application of 202. 4 of the Rules, the details are as follows.

Where the vertical manhole is at a height of more than 600 mm above the walking level, it should be demonstrated that an injured person can be easily evacuated.



4. In application of 202. 5 of the Rules, the details are as follows.

(1) MA for access to ballast tanks, cargo tanks and spaces other than FPT:

For oil tankers:

(A) Tanks and subdivisions of tanks having a length of 35 m or more with two access hatchways:

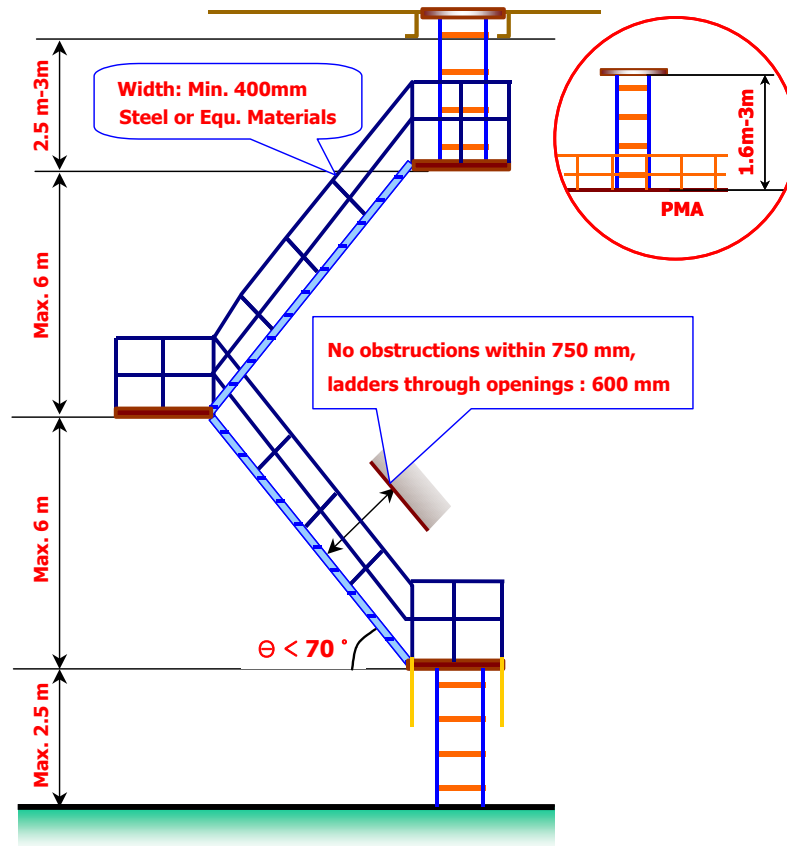
(a) First access hatchway: Inclined ladder or ladders are to be used.

(b) Second access hatchway:

(i) A vertical ladder may be used. In such a case where the vertical distance is more than 6 m, vertical ladders should comprise one or more ladder linking platforms spaced not more than 6 m apart vertically and displaced to one side of the ladder.

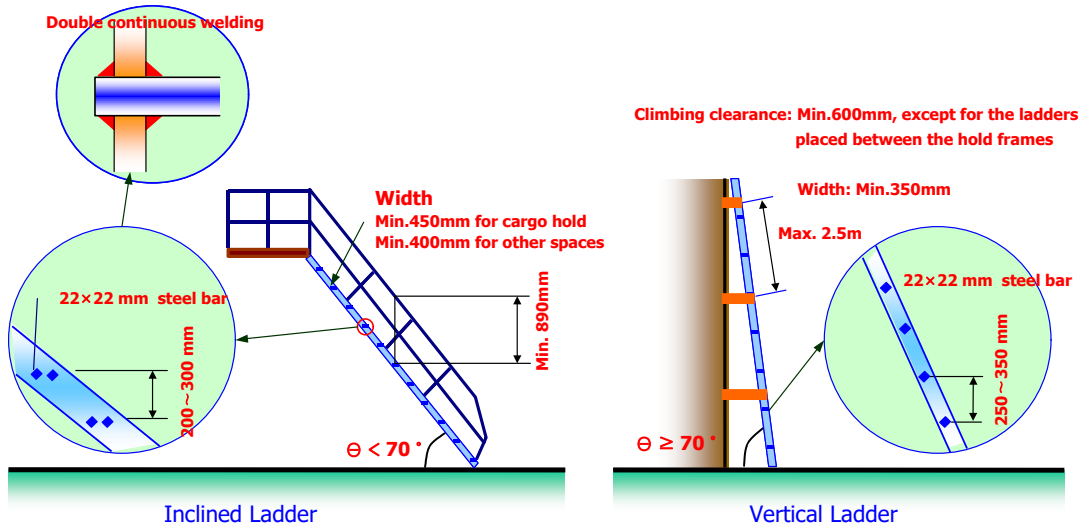
The uppermost section of the vertical ladder, measured clear of the overhead obstructions in way of the tank entrance, should not be less than 2.5 m but not exceed 3.0 m and should comprise a ladder linking platform which should be displaced to one side of a vertical ladder. However, the vertical distance of the upper most section of the vertical ladder may be reduced to 1.6 m, measured clear of the overhead obstructions in way of the tank entrance, if the ladder lands on a longitudinal or athwartship permanent means of access fitted within that range. Adjacent sections of the ladder are to be laterally offset from each other by at least the width of the ladder (see paragraph 20 of MSC/Circ.686 and refer to the interpretation of Technical Provision, resolution MSC.158(78), paragraph 3.13.2 and paragraph 3.13.6); or (2017)

- (ii) Where an inclined ladder or combination of ladders is used for access to the space, the uppermost section of the ladder, measured clear of the overhead obstructions in way of the tank entrance, should be vertical for not less than 2.5 m but not exceed 3.0 m and should comprise a landing platform continuing with an inclined ladder. However, the vertical distance of the upper most section of the vertical ladder may be reduced to 1.6 m, measured clear of the overhead obstructions in way of the tank entrance, if the ladder lands on a longitudinal or athwartship permanent means of access fitted within that range. The flights of the inclined ladders are normally to be not more than 6 m in vertical height. The lowermost section of the ladders may be vertical for the vertical distance not exceeding 2.5 m.
- (B) Tanks less than 35 m in length and served by one access hatchway an inclined ladder or combination of ladders are to be used to the space as specified in (1) (ii) above.
- (C) In double hull spaces of less than 2.5 m width the access to the space may be by means of vertical ladders that comprises one or more ladder linking platforms spaced not more than 6 m apart vertically and displaced to one side of the ladder. The uppermost section of the vertical ladder, measured clear of the overhead obstructions in way of the tank entrance, should not be less than 2.5 m but not exceed 3.0 m and should comprise a ladder linking platform which should be displaced to one side of a vertical ladder. However, the vertical distance of the upper most section of the vertical ladder may be reduced to 1.6 m, measured clear of the overhead obstructions in way of the tank entrance, if the ladder lands on a longitudinal or athwartship permanent means of access fitted within that range. Adjacent sections of the ladder should be laterally offset from each other by at least the width of the ladder. (see paragraph 20 of MSC/Circ.686 and refer to the interpretation of Technical Provision, resolution MSC.158(78), paragraph 3.13.2 and paragraph 3.13.6) (2017)
- (D) Access from deck to a double bottom space may be by means of vertical ladders through a trunk. The vertical distance from deck to a resting platform, between resting platforms or a resting platform and the tank bottom is not be more than 6 m unless otherwise approved by the Administration.
- (2) MA for inspection of the vertical structure of oil tankers:  
Vertical ladders provided for means of access to the space may be used for access for inspection of the vertical structure.  
Unless stated otherwise in Table 1 of TP, vertical ladders that are fitted on vertical structures for inspection should comprise one or more ladder linking platforms spaced not more than 6 m apart vertically and displace to one side of the ladder. Adjacent sections of ladder should be laterally offset from each other by at least the width of the ladder. (see paragraph 20 of MSC/Circ.686 and refer to the interpretation of Technical Provision, resolution MSC.158(78), paragraph 3.13.2 and paragraph 3.13.6) (2017)
- (3) Obstruction distances  
The minimum distance between the inclined ladder face and obstructions, i.e. 750 mm and, in way of openings, 600 mm specified in **202. 5** of the Rules is to be measured perpendicular to the face of the ladder.

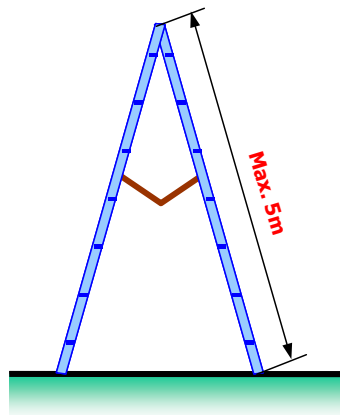


5. In application of 202. 6 of the Rules, the details are as follows.

- (1) Vertical height of handrails is not to be less than 890 mm from the center of the step and two course handrails need only be provided where the gap between stringer and top handrail is greater than 500 mm.
- (2) The requirement of two square bars for treads specified in TP 3.6 is based upon the specification of construction of ladders in paragraph 3(e) of Annex 1 to resolution A.272(VIII), which addresses inclined ladders. TP.3.4 allows for single rungs fitted to vertical surfaces, which is considered for a safe grip. For vertical ladders, when steel is used, the rungs should be formed of single square bars of not less than 22 mm by 22 mm for the sake of safe grip.
- (3) The width of inclined ladders for access to a cargo hold is to be at least 450 mm to comply Australian AMSA Marine Orders Part 32, Appendix 17.
- (4) The width of inclined ladders other than an access to a cargo hold is to be not less than 400 mm.
- (5) The minimum width of vertical ladders is to be 350 mm and the vertical distance between the rungs is to be equal and is to be between 250 mm and 350 mm.
- (6) A minimum climbing clearance in width is to be 600 mm other than the ladders placed between the hold frames.
- (7) The vertical ladders should be secured at intervals not exceeding 2.5 m apart to prevent vibration.



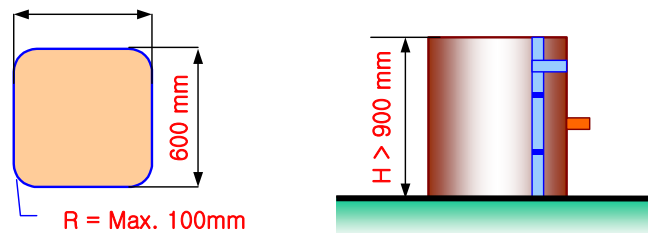
6. In application of **202. 8** of the Rules, the details are as follows.

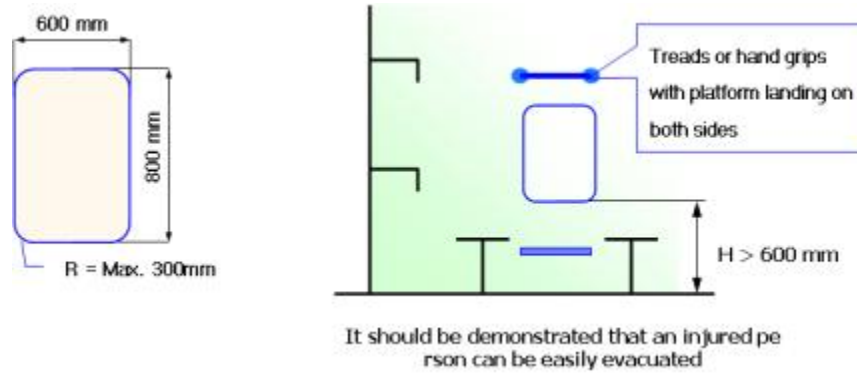


7. In application of **202. 9** (6) of the Rules, the details are as follows. A mechanical device such as hooks for securing at the upper end of a ladder is considered an appropriate securing device if a movement fore/aft and sideways can be prevented at the upper end of the ladder. In **202. 9** (7) the Rules, the "other means of access, approved by and acceptable to this Society" means the case where the means are approved by **Pt 1, Ch 1, 104.** or **105.** of the Guidance or equivalent means.

8. In application of **202. 10** and **11** of the Rules, the details are as follows.

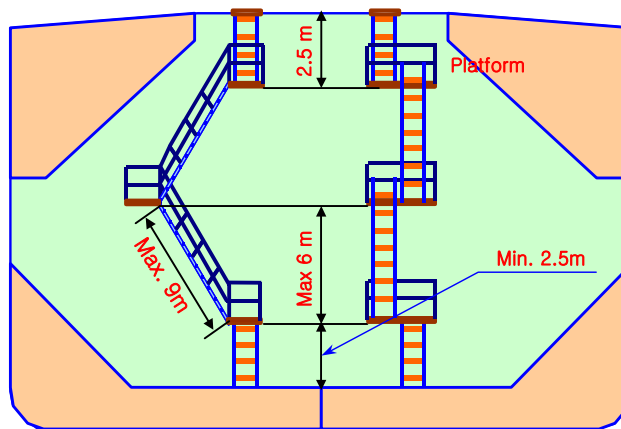
See the **202. 10** and **11** of the Guidances.





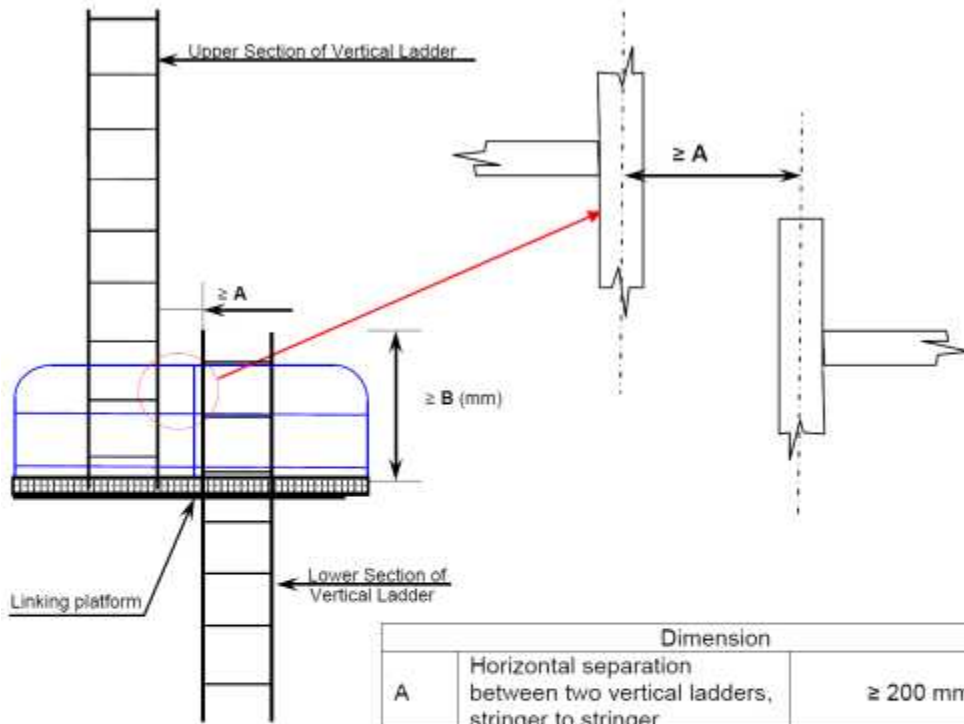
9. In application of **202. 13** of the Rules, the details are as follows.

- (1) Either a vertical or an inclined ladder or a combination of them may be used for access to a cargo hold where the vertical distance is 6 m or less from the deck to the bottom of the cargo hold.



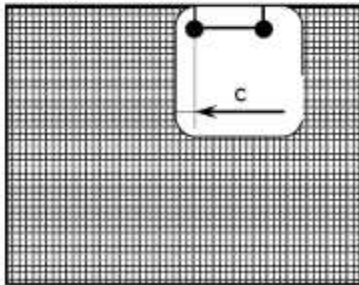
- (2) Adjacent sections of vertical ladder need to be installed so that the following provisions are complied with:
  - (A) the minimum “lateral offset”. between two adjacent sections of vertical ladder, is the distance between the sections, upper and lower, so that the adjacent stringers are spaced at least 200 mm apart, measured from half thickness of each stringer.
  - (B) adjacent sections of vertical ladder shall be installed so that the upper end of the lower section is vertically overlapped, in respect to the lower end of the upper section, to a height of 1500 mm in order to permit a safe transfer between ladders.
  - (C) no section of the access ladder shall be terminated directly or partly above an access opening.

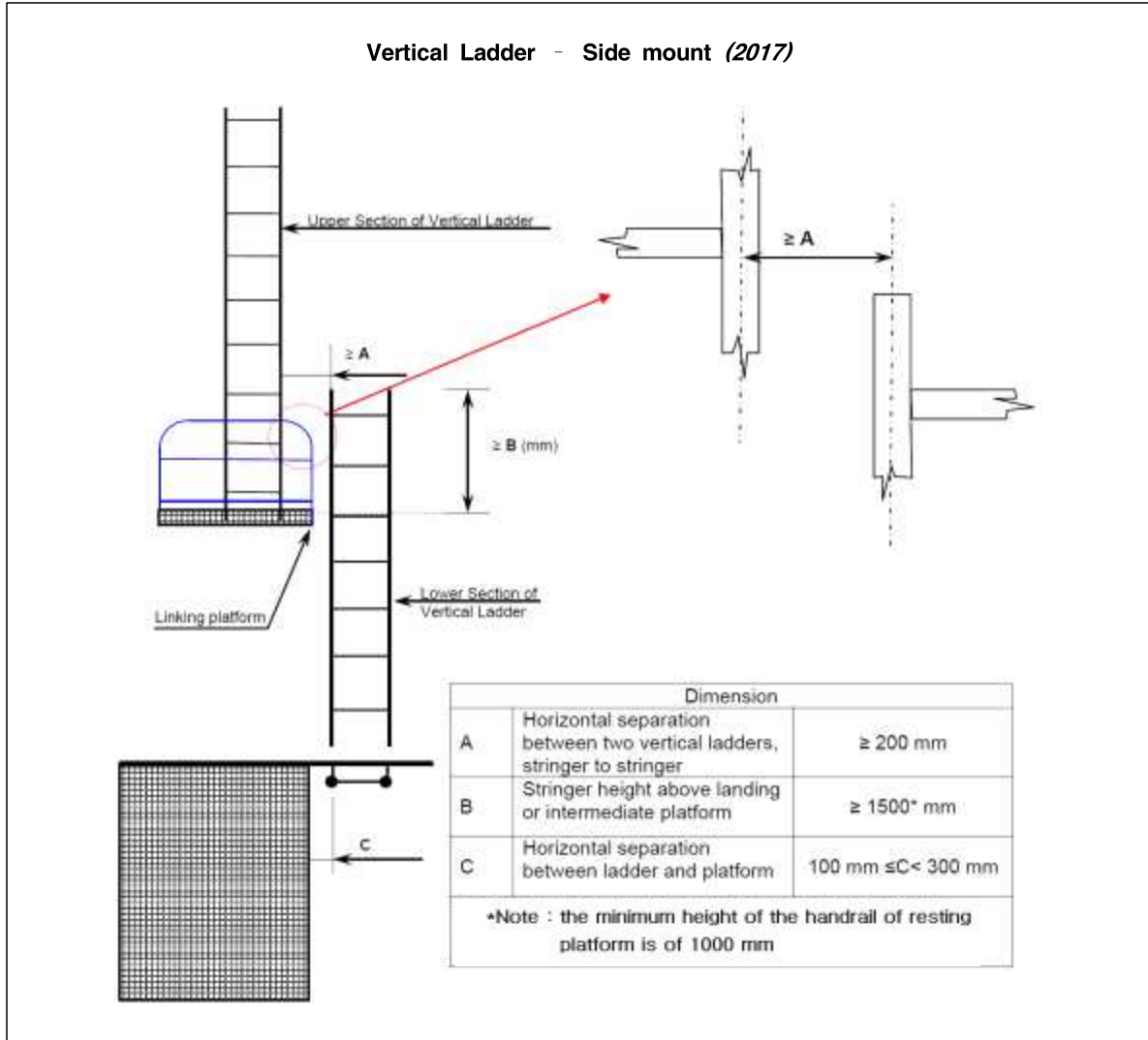
Vertical Ladder - Ladder through the linking platform (2017)



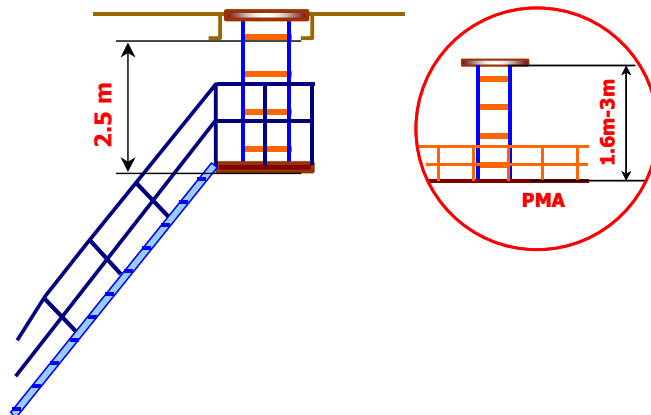
Dimension		
A	Horizontal separation between two vertical ladders, stringer to stringer	$\geq 200$ mm
B	Stringer height above landing or intermediate platform	$\geq 1500^*$ mm
C	Horizontal separation between ladder and platform	$100 \text{ mm} \leq C < 300 \text{ mm}$

\*Note : the minimum height of the handrail of resting platform is of 1000 mm





10. In application of 202. 14 of the Rules, the "deck" is defined as weather deck and the details are as follows.



**203. Corrosion protection [See Rule]**

In application of **203.** of the Rules, the details are as follows.

1. Permanent means of access in dedicated seawater ballast tanks in all types of ships and double-side skin spaces of bulk carriers
  - (1) Permanent means of access arrangements that are integral to the ship structure shall be coated in accordance with the Performance standard for protective coatings for dedicated seawater ballast tanks of all types of ships and double-side skin spaces of bulk carriers (PSPC) (resolution MSC.215(82)).
  - (2) Guidelines for PMAs that are not part of the structural strength elements
    - (A) Hot dip galvanizing should be employed as the primary means for corrosion protection for the ladders, rails, walkways, gratings, stanchions, etc. Hot dip galvanizing and repairs of damages should be performed in accordance with KS D ISO 1461
    - (B) The galvanized items should be subsequently coated in accordance with KS M ISO 12944-5 or the coating manufacturer's recommendation.
    - (C) Where protective coating is applied as the sole means of corrosion protection for these PMAs, the standard in resolution MSC.215(82) should be applied to the extent possible. In such cases, the protective coating should at least comply with the requirements of the PSPC for the job specification, coating system (epoxy-based system) and total NDFT (320 µm).
2. Permanent means of access in void spaces
  - (1) Permanent means of access arrangements in void spaces that are integral to the ship structure should be coated in accordance with the Performance standard for protective coatings for void spaces (resolution MSC.244(83)).
  - (2) Guidelines for PMAs that are not part of the structural strength elements
    - (A) Hot dip galvanizing should be employed as the primary means for corrosion protection for these PMAs. The galvanized items should be subsequently coated according to the coating manufacturer's recommendation.
    - (B) Where protective coating is applied as the sole means of corrosion protection for these items, the Performance standard for protective coatings for void spaces (resolution MSC.244(83)), should be applied to the extent possible. In such case, the protective coating should at least comply with the requirements for the coating system (epoxy-based system) and total NDFT (200 µm) of that standard. ↓

## Annex 4-1 Means of Access for Ballast and Cargo Tanks of Oil Tankers

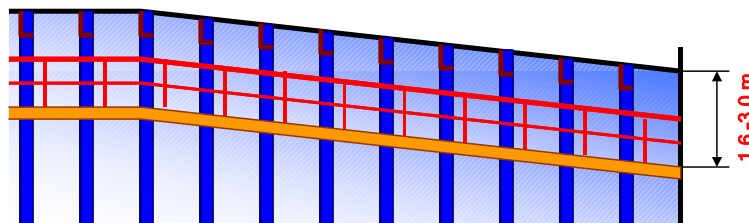
In application of **Ch 11, Table 4.11.1** of the Rules, the details are as follows.

### 1. Water ballast tanks, except those specified in **Par 2**, and cargo oil tanks

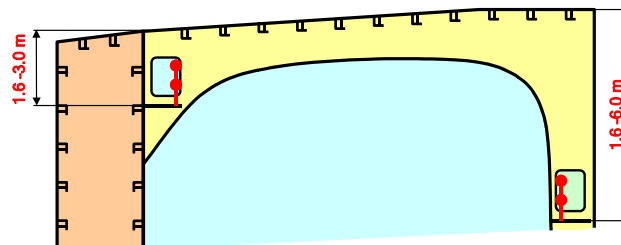
#### 1.1

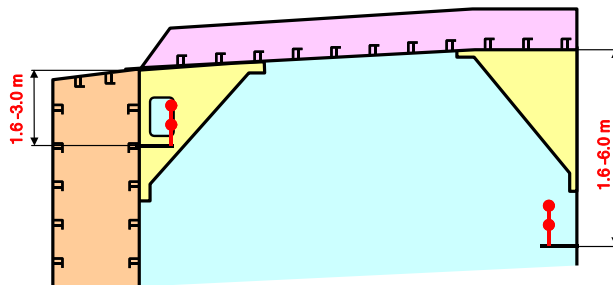
- (1) Sub-paragraphs .1, .2 and .3 define access to underdeck structure, access to the uppermost sections of transverse webs and connection between these structures.
- (2) Sub-paragraphs .4, .5 and .6 define access to vertical structures only and are linked to the presence of transverse webs on longitudinal bulkheads.
- (3) If there are no underdeck structures (deck longitudinals and deck transverses) but there are vertical structures in the cargo tank supporting transverse and longitudinal bulkheads, access in accordance with sub-paragraphs from .1 through to .6 is to be provided for inspection of the upper parts of vertical structure on transverse and longitudinal bulkheads.
- (4) If there is no structure in the cargo tank, section 1.1 of Table 1 is not applicable.
- (5) Section 1 of Table 1 is also to be applied to void spaces in cargo area, comparable in volume to spaces covered by the regulation II-1/3-6, except those spaces covered by Section 2.
- (6) The vertical distance below the overhead structure is to be measured from the underside of the main deck plating to the top of the platform of the means of access at a given location.
- (7) The height of the tank is to be measured at each tank. For a tank the height of which varies at different bays item 1.1 is to be applied to such bays of a tank that have height 6 m and over.

#### 1.1.1



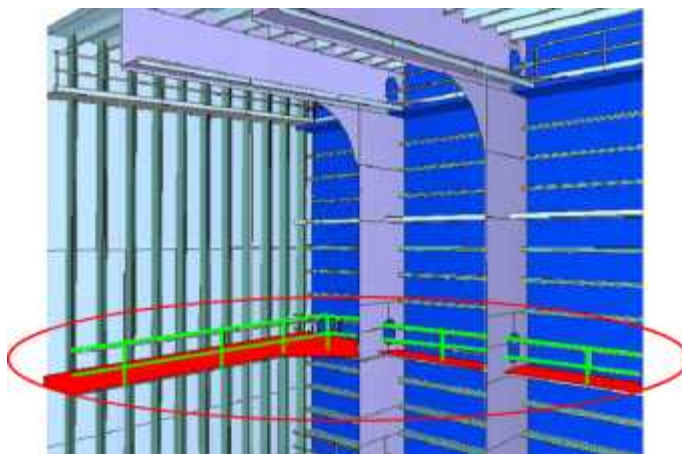
- 1.1.2 There is need to provide continuous longitudinal permanent means of access when the deck longitudinals and deck transverses are fitted on deck but supporting brackets are fitted under the deck.



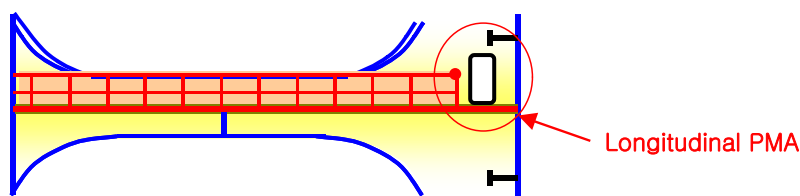


1.1.3 Means of access to tanks may be used for access to the permanent means of access for inspection.

1.1.4 The permanent fittings required to serve alternative means of access such as wire lift platform, that are to be used by crew and surveyors for inspection should provide at least an equal level of safety as the permanent means of access stated by the same paragraph. These means of access shall be carried on board the ship and be readily available for use without filling of water in the tank. Therefore, rafting is not acceptable under this provision. Alternative means of access are to be part of Access Manual which is to be approved on behalf of the flag State. For water ballast tanks of 5 m or more in width, such as on an ore carrier, side shell plating shall be considered in the same way as “longitudinal bulkhead”.



1.1.5

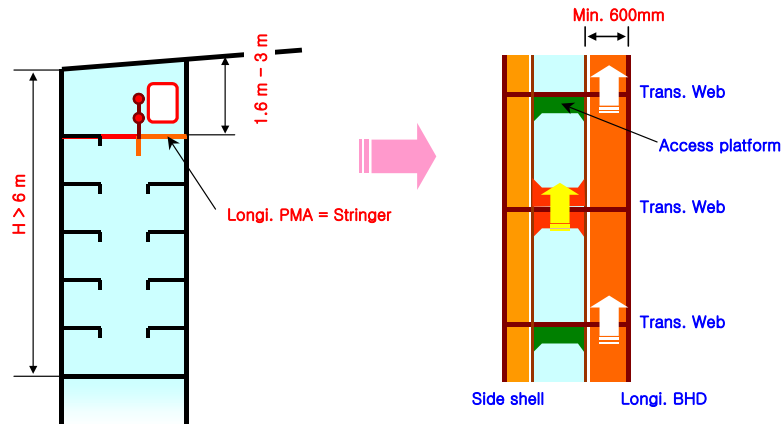


2. Water ballast wing tanks of less than 5 m width forming double side spaces and their bilge hopper sections

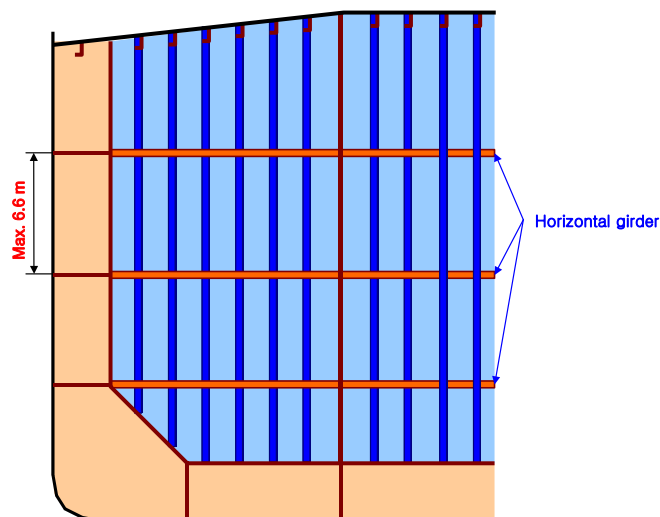
2.1 Par 2 of Table 4.11.1 is also to be applied to wing tanks designed as void spaces. Paragraph 2.1.1 represents requirements for access to underdeck structures, while paragraph 2.1.2 is a requirement for access for survey and inspection of vertical structures on longitudinal bulkheads (transverse webs).

2.1.1

- (1) For a tank the vertical distance between horizontal upper stringer and deck head of which varies at different sections item 2.1.1 is to be applied to such sections that falls under the criteria.
- (2) The continuous permanent means of access may be a wide longitudinal, which provides access to critical details on the opposite side by means of platforms as necessary on web frames. In case the vertical opening of the web frame is located in way of the open part between the wide longitudinal and the longitudinal on the opposite side, platforms shall be provided on both sides of the web frames to allow safe passage through the web frame.
- (3) Where two access hatches are required by SOLAS regulation II-1/3-6.3.2, access ladders at each end of the tank are to lead to the deck.

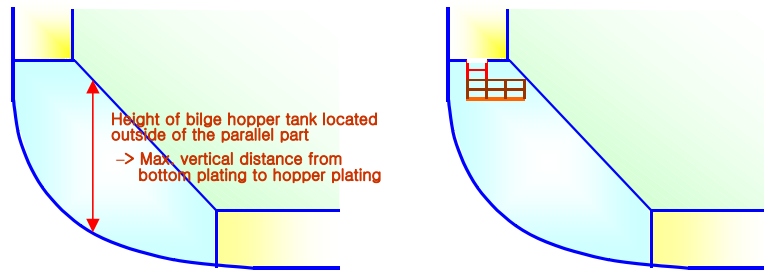


- 2.1.2 The continuous permanent means of access may be a wide longitudinal, which provides access to critical details on the opposite side by means of platforms as necessary on web frames. In case the vertical opening of the web is located in way of the open part between the wide longitudinal and the longitudinal on the opposite side, platforms shall be provided on both sides of the web to allow safe passage through the web. A "reasonable deviation" as noted in TP/1.4, of not more than 10% may be applied where the permanent means of access is integral with the structure itself.

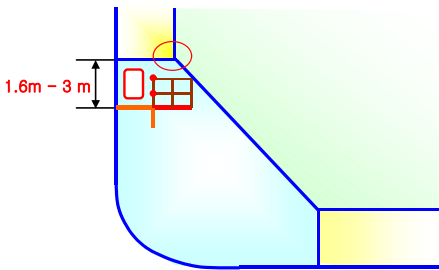


2.2

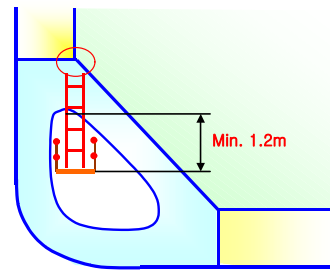
- (1) Permanent means of access between the longitudinal continuous permanent means of access and the bottom of the space is to be provided.
- (2) The height of a bilge hopper tank located outside of the parallel part of vessel is to be taken as the maximum of the clear vertical distance measured from the bottom plating to the hopper plating of the tank.
- (3) The foremost and aftmost bilge hopper ballast tanks with raised bottom, of which the height is 6 m and over, a combination of transverse and vertical MA for access to the upper knuckle point for each transverse web is to be accepted in place of the longitudinal permanent means of access.



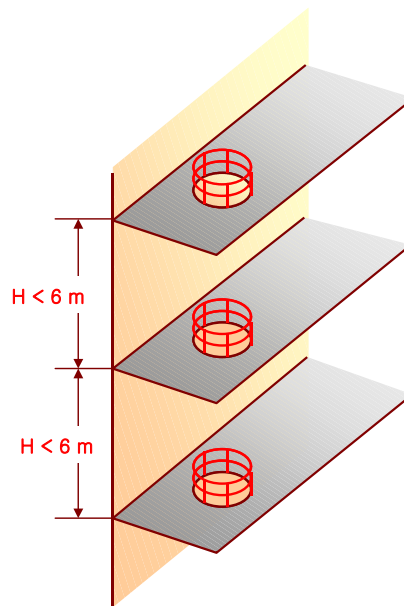
2.2.1



2.2.2



2.3



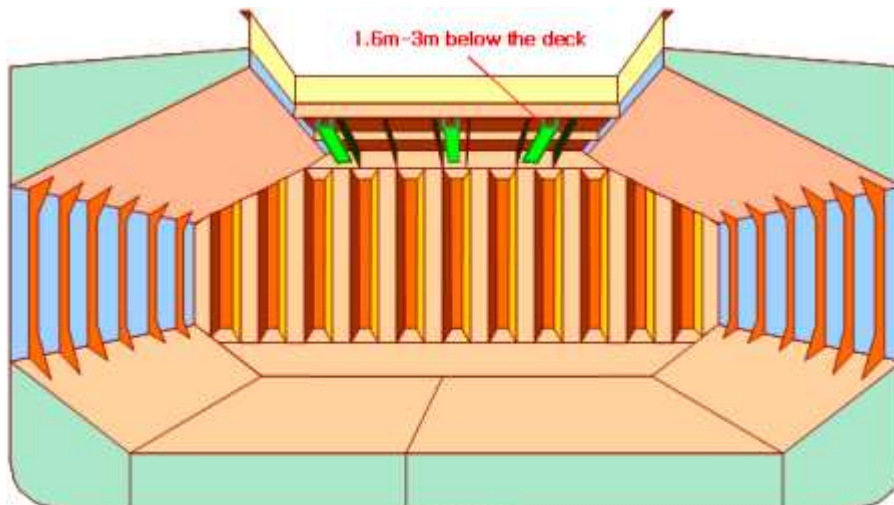
## Annex 4-2 Means of Access for Bulk Carriers

In application of Ch 11, Table 4.11.2 of the Rules, the details are as follows.

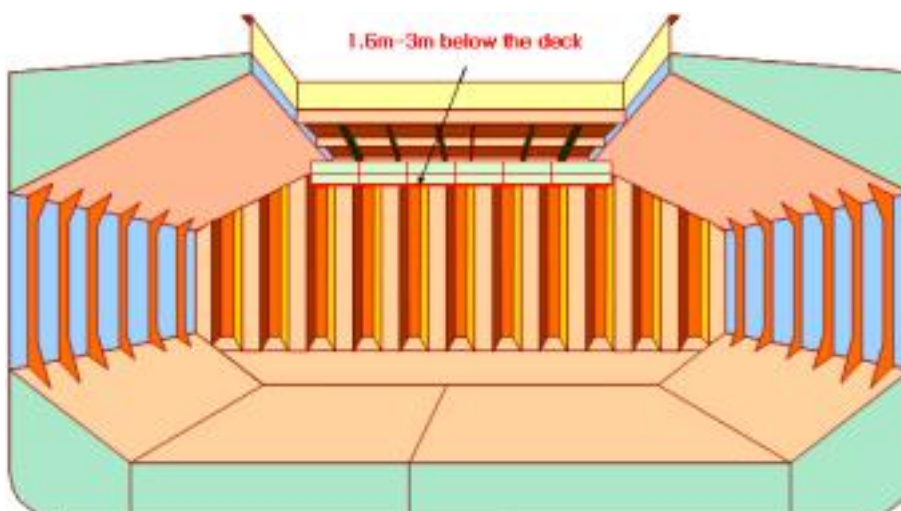
### 1. Cargo holds

#### 1.1

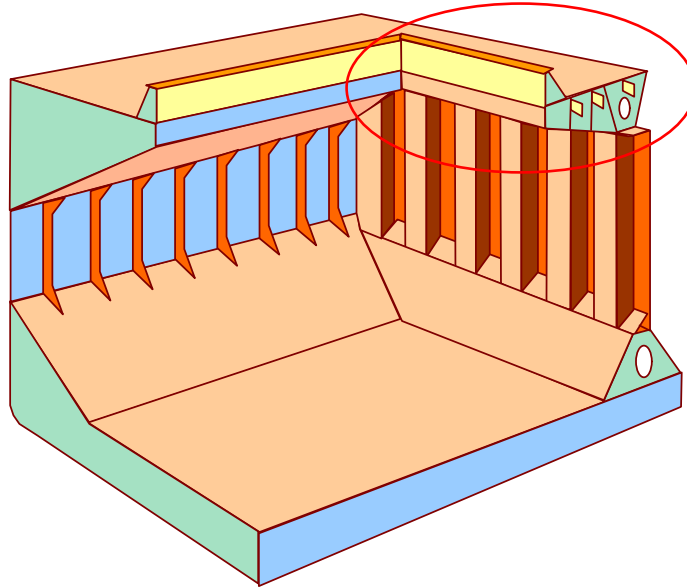
- (1) Means of access shall be provided to the crossdeck structures of the foremost and aftermost part of the each cargo hold.
- (2) Interconnected means of access under the cross deck for access to three locations at both sides and in the vicinity of the centerline is acceptable as the three means of access.
- (3) Permanent means of access fitted at three separate locations accessible independently, one at each side and one in the vicinity of the centerline is acceptable.
- (4) Special attention is to be paid to the structural strength where any access opening is provided in the main deck or cross deck.
- (5) The requirements for bulk carrier cross deck structure is also considered applicable to ore carriers.



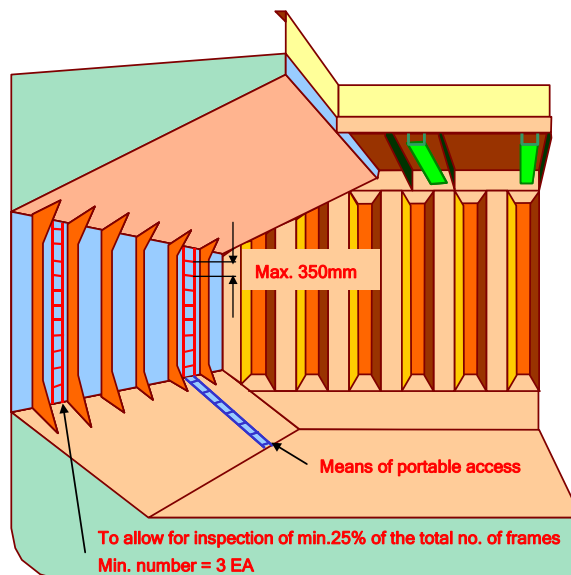
#### 1.2



- 1.3 Particular attention is to be paid to preserve the structural strength in way of access opening provided in the main deck or cross deck.
- 1.4 "Full upper stools" are understood to be stools with a full extension between top side tanks and between hatch end beams.



- 1.5
  - (1) The movable means of access to the underdeck structure of cross deck need not necessarily be carried on board the vessel. It is sufficient if it is made available when needed.
  - (2) The requirements for bulk carrier cross deck structure is also considered applicable to ore carriers.
- 1.6
  - (1) The maximum vertical distance of the rungs of vertical ladders for access to hold frames is to be 350 mm.
  - (2) If safety harness is to be used, means should be provided for connecting the safety harness in suitable places in a practical way.

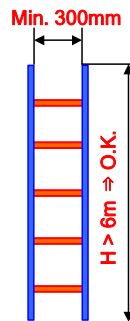


1.7 Portable, movable or alternative means of access also is to be applied to corrugated bulkheads.

1.8 Readily available means ;

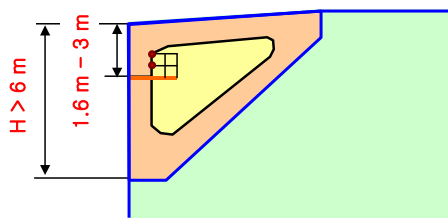
Able to be transported to location in cargo hold and safely erected by ship's staff.

1.10

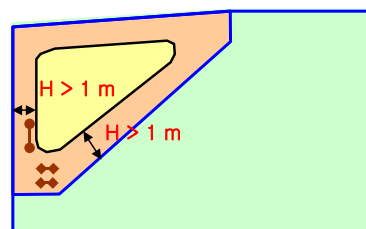


## 2. Ballast tanks

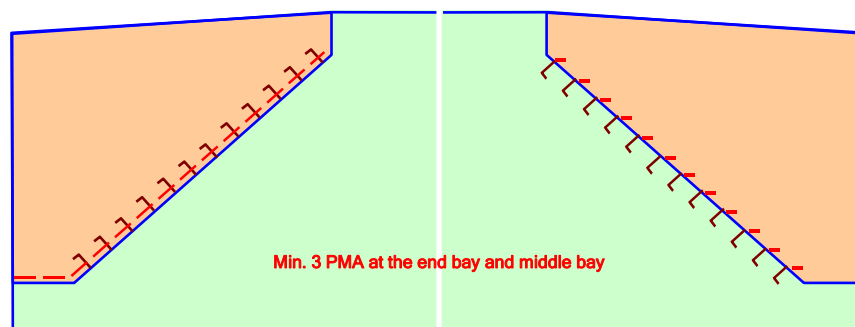
2.1



2.2

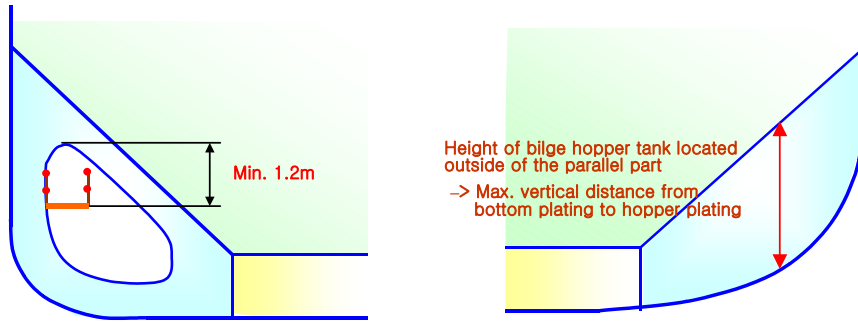


2.3 If the longitudinal structures on the sloping plate are fitted outside of the tank a means of access is to be provided.

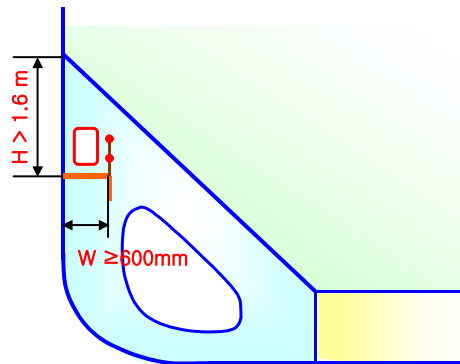


2.5

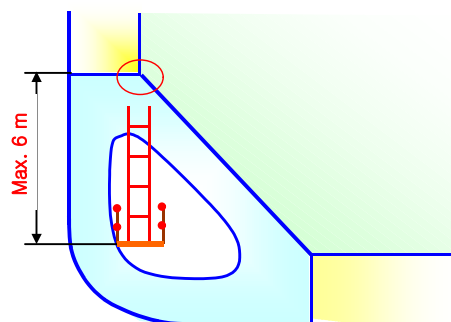
- (1) The height of a bilge hopper tank located outside of the parallel part of vessel is to be taken as the maximum of the clear vertical height measured from the bottom plating to the hopper plating of the tank.
- (2) It should be demonstrated that portable means for inspection can be deployed and made readily available in the areas where needed.



2.5.2 A wide longitudinal frame of at least 600 mm clear width may be used for the purpose of the longitudinal continuous permanent means of access. The foremost and aftermost bilge hopper ballast tanks with raised bottom, of which the height is 6 m and over, a combination of transverse and vertical MA for access to the sloping plate of hopper tank connection with side shell plating for each transverse web can be accepted in place of the longitudinal permanent means of access.



2.5.3



2.6 The height of web frame rings should be measured in way of side shell and tank base. ↓

## Annex 4-3 Anchoring in Deep and Unsheltered Waters (2019)

### 1. Application

- (1) The requirements in this Annex are applicable to anchoring equipment for ships with a rule length of not less than 135 m in deep and unsheltered water.
- (2) Assumed conditions are as follows:
  - (A) water depth up to 120 m
  - (B) current up to 1.54 m/s, wind up to 14 m/s, waves with significant height of up to 3 m

### 2. Equipment Number for deep and unsheltered water

Anchors and chain cables are to be in accordance with **Table 1** and based on the Equipment Number  $E_1$  obtained from the following equation:

$$E_1 = 0.628 \left[ a \left( \frac{E}{0.628} \right)^{1/2.3} + b(1-a) \right]^{2.3}$$

$$a = 1.83 \cdot 10^{-9} L^3 + 2.09 \cdot 10^{-6} L^2 - 6.21 \cdot 10^{-4} L + 0.0866$$

$$b = 0.156 L + 8.372$$

$L$ : Rule length (m), as specified in **Pt 3, Ch 1, 102.** of the Rules

$E$ : Equipment Number calculated in compliance with **Ch 8, 201.** of the Rules

Table 1 Anchoring equipment for ships in unsheltered water with depth up to 120 m

Equipment Number $E_1$		High holding power stockless bower anchor		Stud link chain cable for bower anchors		
		Number	Mass per anchor (kg)	Length (m)	Min. diameter	
Exceeding	Not exceeding				Grade 2 (mm)	Grade 3 (mm)
	1790	2	14150	1017.5	105	84
1790	1930	2	14400	990	105	84
1930	2080	2	14800	990	105	84
2080	2230	2	15200	990	105	84
2230	2380	2	15600	990	105	84
2380	2530	2	16000	990	105	84
2530	2700	2	16300	990	105	84
2700	2870	2	16700	990	105	84
2870	3040	2	17000	990	105	84
3040	3210	2	17600	990	105	84
3210	3400	2	18000	990	105	84
3400	3600	2	18300	990	105	84
3600	3800	2	19000	990	107	87
3800	4000	2	19700	962.5	107	87
4000	4200	2	20300	962.5	111	90
4200	4400	2	21100	962.5	114	92
4400	4600	2	22000	962.5	117	95
4600	4800	2	22900	962.5	120	97
4800	5000	2	23500	962.5	124	99
5000	5200	2	24000	935	127	102
5200	5500	2	24500	907.5	132	107
5500	5800	2	25000	907.5	132	107
5800	6100	2	25500	880	137	111
6100	6500	2	25700	880	142	114
6500	6900	2	26000	852.5	142	117
6900	7400	2	26500	852.5	147	117
7400	7900	2	27000	825	152	122
7900	8400	2	27500	825	-	127
8400	8900	2	28000	797.5	-	127
8900	9400	2	28900	770	-	132
9400	10000	2	29400	770	-	137
10000	10700	2	29900	770	-	142
10700	11500	2	30600	770	-	142
11500	12400	2	31500	770	-	147
12400	13400	2	33200	770	-	152
13400	14600	2	35000	770	-	157
14600		2	38000	770	-	162

### 3. Anchors

- (1) The bower anchors are to be connected to their chain cables and positioned on board ready for use.
- (2) Anchors are to be of the stockless high holding power (H.H.P.) type.
- (3) The mass of the head of a stockless anchor, including pins and fittings, is not to be less than 60% of the total mass of the anchor. The requirements for H.H.P. anchors are given in **Ch 8, 304. 2.** of the Rules and **Ch 8, 304.** of the Guidance.
- (4) The mass, per anchor, of bower anchors given in **Table 1** is for anchors of equal mass. The mass of individual anchors may vary to 7% of the tabular mass, but the total mass of anchors shall not be less than that recommended for anchors of equal mass.
- (5) For manufacture and testing of the anchors is to be in accordance with the requirements of **Ch 8** of the Rules.

### 4. Chain cables for bower anchors

- (1) Bower anchors shall be accompanied with stud link chain cables of Grade 2 or Grade 3 quality. The total length of chain cable, as given in **Table 1**, shall be reasonably divided between the two bower anchors. The proof and breaking loads of stud link chain cables shall be in accordance with **Ch 8, Table 4.8.8** of the Rules.
- (2) For manufacture and installation of the chain cables is to be in accordance with the requirements of **Ch 8** of the Rules.

### 5. Anchor windlass and chain stopper

- (1) Anchor windlass design and testing and the chain stopper design is to be in accordance with **Pt 5, Ch 8** of the Rules.
- (2) In addition to the requirements according to **Pt 5, Ch 8** of the Rules, the windlass unit prime mover is to be able to supply for at least 30 minutes a continuous duty pull  $Z_{cont}$ , in N, given by:

$$Z_{cont} = 35d^2 + 13.4m_A$$

$d$  : chain diameter, in mm, as per **Table 1**

$m_A$  : H.H.P. anchor mass, in kg, as per **Table 1**.

- (3) In addition to the requirements according to **Pt 5, Ch 8** of the Rules, as far as practicable, for testing purpose the speed of the chain cable during hoisting of the anchor and cable is to be measured over 37.5 m of chain cable and initially with at least 120 m of chain and the anchor submerged and hanging free. The mean speed of the chain cable during hoisting of the anchor from the depth of 120 m to the depth of 82.5 m is to be at least 4.5 m/min.
- (4) Hull supporting structure of anchor windlass and chain stopper is to be in accordance with **Ch 8, 101. 4. (6)** of the Rules.

**Rules for the Classification of Steel Ships  
Guidance Relating to the Rules for the Classification  
of Steel Ships**

---

## **PART 4 HULL EQUIPMENT**

Published by

**KR**

36, Myeongji ocean city 9-ro, Gangseo-gu,  
BUSAN, KOREA

TEL : +82 70 8799 7114

FAX : +82 70 8799 8999

Website : <http://www.krs.co.kr>

---

Copyright© 2019, **KR**

Reproduction of this Rules and Guidance in whole or in  
parts is prohibited without permission of the publisher.