



**2019**

---

**Rules and Guidances for the Classification of  
Ships Using Low-flashpoint Fuels**

---

**KR**

2019

Rules for the Classification of

**Ships Using Low-flashpoint Fuels**

---

---

**Rules**

2019

Guidance Relating to the Rules for the Classification of

**Ships Using Low-flashpoint Fuels**

---

---

**Guidance**



**2019**

---

**Rules for the Classification of  
Ships Using Low-flashpoint Fuels**

# **APPLICATION OF "RULES FOR SHIPS USING LOW-FLASHPOINT FUELS "**

1. Unless expressly specified otherwise, the requirements in the Rules apply to ships using low-flashpoint fuels for which contracts for construction are signed on or after 1 July 2019.
2. The amendments to the Rules for 2018 edition and their effective date are as follows;

**Effective Date : 1 July 2019 (Based on Application Date for Classification Survey)**

## **CHAPTER 4 CLASSIFICATION SURVEYS**

- Section 3 Periodical Surveys  
- 303. 4 (2) has been amended.

**Effective Date : 1 July 2019**

## **CHAPTER 3 GENERAL REQUIREMENTS**

- Section 2 Risk assessment  
- 201. 3 has been amended.

## CONTENTS

<b>CHAPTER 1</b>	<b>GENERAL</b>	<b>1</b>
Section 1	General	1
<b>CHAPTER 2</b>	<b>GOAL AND FUNCTIONAL REQUIREMENTS</b>	<b>5</b>
Section 1	Goal (IGF Code 3.1)	5
Section 2	Functional requirements (IGF Code 3.2)	5
<b>CHAPTER 3</b>	<b>GENERAL REQUIREMENTS</b>	<b>7</b>
Section 1	Goal (IGF Code 4.1)	7
Section 2	Risk assessment (IGF Code 4.2)	7
Section 3	Limitation of explosion consequences (IGF Code 4.3)	7
<b>CHAPTER 4</b>	<b>CLASSIFICATION SURVEYS</b>	<b>9</b>
Section 1	General	9
Section 2	Classification	9
Section 3	Periodical Surveys	11
<b>CHAPTER 5</b>	<b>SHIP DESIGN AND ARRANGEMENT</b>	<b>15</b>
Section 1	Goal (IGF Code 5.1)	15
Section 2	Functional requirements (IGF Code 5.2)	15
Section 3	Arrangement of fuel tanks (IGF Code 5.3)	15
Section 4	Machinery space concepts (IGF Code 5.4)	18
Section 5	Gas safe machinery space (IGF Code 5.5)	18
Section 6	ESD-protected machinery space (IGF Code 5.6)	18
Section 7	Location and protection of fuel piping (IGF Code 5.7)	19
Section 8	Fuel preparation room (IGF Code 5.8)	19
Section 9	Bilge systems (IGF Code 5.9)	19
Section 10	Drip trays (IGF Code 5.10)	19
Section 11	Arrangement of entrances and other openings in enclosed spaces (IGF Code 5.11)	20
Section 12	Airlocks (IGF Code 5.12)	20
<b>CHAPTER 6</b>	<b>FUEL CONTAINMENT SYSTEM</b>	<b>21</b>
Section 1	Goal (IGF Code 6.1)	21
Section 2	Functional requirements (IGF Code 6.2)	21
Section 3	General requirements (IGF Code 6.3)	21
Section 4	Liquefied gas fuel containment (IGF Code 6.4)	22
Section 5	Portable liquefied gas fuel tanks (IGF Code 6.5)	43
Section 6	CNG fuel containment (IGF Code 6.6)	44
Section 7	Pressure relief system (IGF Code 6.7)	44
Section 8	Loading limit for liquefied gas fuel tanks (IGF Code 6.8)	48
Section 9	Maintaining of fuel storage condition (IGF Code 6.9)	48
Section 10	Atmosphere control within the fuel containment system (IGF Code 6.10)	50

Section 11	Atmosphere control within the fuel hold spaces (Fuel containment systems other than Type C independent tanks (IGF Code 6.11) .....	50
Section 12	Environmental control of spaces surrounding type C independent tanks (IGF Code 6.12) .....	50
Section 13	Inerting (IGF Code 6.13) .....	50
Section 14	Inert gas production and storage on board (IGF Code 6.14) .....	51
<b>CHAPTER 7</b>	<b>MATERIAL AND GENERAL PIPE DESIGN .....</b>	<b>53</b>
Section 1	Goal (IGF Code 7.1) .....	53
Section 2	Functional requirements (IGF Code 7.2) .....	53
Section 3	Pipe design (IGF Code 7.3) .....	53
Section 4	Materials (IGF Code 7.4) .....	56
<b>CHAPTER 8</b>	<b>BUNKERING .....</b>	<b>61</b>
Section 1	Goal (IGF Code 8.1) .....	61
Section 2	Functional requirements (IGF Code 8.2) .....	61
Section 3	Bunkering station (IGF Code 8.3) .....	61
Section 4	Manifold (IGF Code 8.4) .....	62
Section 5	Bunkering system (IGF Code 8.5) .....	62
<b>CHAPTER 9</b>	<b>FUEL SUPPLY TO CONSUMERS .....</b>	<b>63</b>
Section 1	Goal (IGF Code 9.1) .....	63
Section 2	Functional requirements (IGF Code 9.2) .....	63
Section 3	Redundancy of fuel supply (IGF Code 9.3) .....	63
Section 4	Safety functions of gas supply system (IGF Code 9.4) .....	63
Section 5	Fuel distribution outside of machinery space (IGF Code 9.5) .....	64
Section 6	Fuel supply to consumers in gas-safe machinery spaces (IGF Code 9.6) .....	64
Section 7	Fuel supply to consumers in ESD-protected machinery spaces (IGF Code 9.7) .....	65
Section 8	Design of ventilated duct, outer pipe against inner pipe gas leakage (IGF Code 9.8) .....	65
Section 9	Compressors and pumps (IGF Code 9.9) .....	66
<b>CHAPTER 10</b>	<b>POWER GENERATION INCLUDING PROPULSION AND OTHER GAS CONSUMER .....</b>	<b>67</b>
Section 1	Goal (IGF Code 10.1) .....	67
Section 2	Functional requirements (IGF Code 10.2) .....	67
Section 3	Internal combustion engines of piston type (IGF Code 10.3) .....	67
Section 4	Main and auxiliary boilers, gas turbine (IGF Code 10.4) .....	68
Section 5	Gas turbines (IGF Code 10.5) .....	69
<b>CHAPTER 11</b>	<b>FIRE SAFETY .....</b>	<b>71</b>
Section 1	Goal (IGF Code 11.1) .....	71
Section 2	Functional requirements (IGF Code 11.2) .....	71
Section 3	Fire protection (IGF Code 11.3) .....	71
Section 4	Fire main (IGF Code 11.4) .....	71
Section 5	Water spray systems (IGF Code 11.5) .....	72

Section 6	Dry chemical powder fire-extinguishing system (IGF Code 11.6)	72
Section 7	Fire detection and alarm (IGF Code 11.7)	72
<b>CHAPTER 12</b>	<b>EXPLOSION PREVENTION</b>	<b>73</b>
Section 1	Goal (IGF Code 12.1)	73
Section 2	Functional requirements (IGF Code 12.2)	73
Section 3	General requirements (IGF Code 12.3)	73
Section 4	Area classification (IGF Code 12.4)	73
Section 5	Hazardous area zone (IGF Code 12.5)	74
<b>CHAPTER 13</b>	<b>VENTILATION</b>	<b>75</b>
Section 1	Goal (IGF Code 13.1)	75
Section 2	Functional requirements (IGF Code 13.2)	75
Section 3	General requirements (IGF Code 13.3)	75
Section 4	Tank connection space (IGF Code 13.4)	76
Section 5	Machinery space (IGF Code 13.5)	77
Section 6	Fuel preparation room (IGF Code 13.6)	77
Section 7	Bunkering station (IGF Code 13.7)	77
Section 8	Ducts and double pipes (IGF Code 13.8)	77
<b>CHAPTER 14</b>	<b>ELECTRICAL INSTALLATIONS</b>	<b>79</b>
Section 1	Goal (IGF Code 14.1)	79
Section 2	Functional requirements (IGF Code 14.2)	79
Section 3	General requirements (IGF Code 14.3)	79
<b>CHAPTER 15</b>	<b>CONTROL, MONITORING AND SAFETY SYSTEMS</b>	<b>81</b>
Section 1	Goal (IGF Code 15.1)	81
Section 2	Functional requirements (IGF Code 15.2)	81
Section 3	General requirements (IGF Code 15.3)	81
Section 4	Bunkering and liquefied gas fuel tank monitoring (IGF Code 15.4)	82
Section 5	Bunkering control (IGF Code 15.5)	83
Section 6	Gas compressor monitoring (IGF Code 15.6)	83
Section 7	Gas engine monitoring (IGF Code 15.7)	83
Section 8	Gas detection (IGF Code 15.8)	84
Section 9	Fire detection (IGF Code 15.9)	84
Section 10	Ventilation (IGF Code 15.10)	87
Section 11	Safety functions of fuel supply systems (IGF Code 15.11)	87
<b>CHAPTER 16</b>	<b>MANUFACTURE, WORKMANSHIP AND TESTING</b>	<b>89</b>
Section 1	General (IGF Code 16.1)	89
Section 2	General test regulations and specifications (IGF Code 16.2)	89
Section 3	Welding of metallic materials and non-destructive testing for the fuel containment system (IGF Code 16.3)	91
Section 4	Other regulations for construction in metallic materials (IGF Code 16.4)	93
Section 5	Testing (IGF Code 16.5)	94
Section 6	Welding, post-weld heat treatment and non-destructive testing (IGF Code 16.1)	95

Section 7 Testing regulations ..... 96

# CHAPTER 1 GENERAL

## Section 1 General

### 101. Application

1. This Rules applies to ships using low-flashpoint fuels. However, does not apply to the ships specified in the following.
  - (1) Ships carrying liquefied gases in bulk using their cargoes as fuel and complying with the requirements of **Pt 7, Ch 5 of Rules for the classification of steel ships**
  - (2) Ships carrying liquefied gases in bulk using other low-flashpoint gaseous fuels provided that the fuel storage and distribution systems design and arrangements for such gaseous fuels comply with the requirements of **Pt 7, Ch 5 of Rules for the classification of steel ships** .
2. Notwithstanding the requirement specified in **1**, for the ships specified in the following (1) or (2), some requirements of this Rules may be modified, as appropriate.
  - (1) ships to which **SOLAS II-1** does not apply; or
  - (2) ships which are subjected to Korean Ship Safety Act and Notification having a restricted to domestic service.
3. **Ch 5 to Ch 15** of this Rules applies to ships using natural gas as fuel, either in its liquefied or gaseous state.
4. In addition to the requirements in this Rules, they meet other related requirements in **Rules for the classification of steel ships** .

### 102. Definitions

The definitions of terms are to be followed to **Rules for the classification of steel ships**, unless otherwise specified in this Rules.

1. **Accidents** means uncontrolled events that may entail the loss of human life, personal injuries, environmental damage or the loss of assets and financial interests.
2. **Breadth (B)** means the greatest moulded breadth of the ship at or below the deepest draught (summer load line draught) (refer to **SOLAS regulation II-1/2.8**).
3. **Bunkering** means the transfer of liquid or gaseous fuel from land based or floating facilities into a ships' permanent tanks or connection of portable tanks to the fuel supply system.
4. **Certified safe type** means electrical equipment that is certified safe by the relevant authorities recognized by the Society for operation in a flammable atmosphere based on a recognized standard. **[See Guidance]**
5. **CNG** means compressed natural gas.(See **26**.)
6. **Control stations** means those spaces defined in **Pt 8 of Rules for the classification of steel ships** and additionally for this Rules, the engine control room.
7. **Design temperature for selection of materials** is the minimum temperature at which liquefied gas fuel may be loaded or transported in the liquefied gas fuel tanks.
8. **Design vapour pressure " $P_0$ "** is the maximum gauge pressure, at the top of the tank, to be used in the design of the tank.
9. **Double block and bleed valve"** means a set of two valves in series in a pipe and a third valve enabling the pressure release from the pipe between those two valves. The arrangement may also consist of a two-way valve and a closing valve instead of three separate valves.
10. **Dual fuel engines** means engines that employ fuel covered by this Rules (with pilot fuel) and oil fuel. Oil fuels may include distillate and residual fuels.
11. **Enclosed space** means any space within which, in the absence of artificial ventilation, the ventilation will be limited and any explosive atmosphere will not be dispersed naturally. **[See Guidance]**

12. **ESD** means emergency shutdown.
13. **Explosion** means a deflagration event of uncontrolled combustion.
14. **Explosion pressure relief** means measures provided to prevent the explosion pressure in a container or an enclosed space exceeding the maximum overpressure the container or space is designed for, by releasing the overpressure through designated openings.
15. **Fuel containment system** is the arrangement for the storage of fuel including tank connections. It includes where fitted, a primary and secondary barrier, associated insulation and any intervening spaces, and adjacent structure if necessary for the support of these elements. If the secondary barrier is part of the hull structure it may be a boundary of the fuel storage hold space. The spaces around the fuel tank are defined as follows:
  - (1) Fuel storage hold space is the space enclosed by the ship's structure in which a fuel containment system is situated. If tank connections are located in the fuel storage hold space, it will also be a tank connection space;
  - (2) Interbarrier space is the space between a primary and a secondary barrier, whether or not completely or partially occupied by insulation or other material; and
  - (3) Tank connection space is a space surrounding all tank connections and tank valves that is required for tanks with such connections in enclosed spaces. **[See Guidance]**
16. **Filling limit (FL)** means the maximum liquid volume in a fuel tank relative to the total tank volume when the liquid fuel has reached the reference temperature.
17. **Fuel preparation room** means any space containing pumps, compressors and/or vaporizers for fuel preparation purposes. **[See Guidance]**
18. **Gas** means a fluid having a vapour pressure exceeding 0.28 MPa absolute at a temperature of 37.8 °C.
19. **Gas consumer** means any unit within the ship using gas as a fuel.
20. **Gas only engine** means an engine capable of operating only on gas, and not able to switch over to operation on any other type of fuel.
21. **Hazardous area** means an area in which an explosive gas atmosphere is or may be expected to be present, in quantities such as to require special precautions for the construction, installation and use of equipment.
22. **High pressure** means a maximum working pressure greater than 1.0 MPa.
23. **Independent tanks** are self-supporting, do not form part of the ship's hull and are not essential to the hull strength.
24. **LEL** means the lower explosive limit.
25. **Length ( $L_f$ )** is the length as defined in the **Regulation 3 of International Convention on Load Lines** in force.
26. **LNG** means liquefied natural gas.
27. **Loading limit (LL)** means the maximum allowable liquid volume relative to the tank volume to which the tank may be loaded.
28. **Low-flashpoint fuel** means gaseous or liquid fuel having a flashpoint lower than otherwise permitted under **Pt 8, Ch2, 101. 1 of Rules for the classification of steel ships**.
29. **MARVS** means the maximum allowable relief valve setting.
30. **MAWP** means the maximum allowable working pressure of a system component or tank.
31. **Membrane tanks** are non-self-supporting tanks that consist of a thin liquid and gas tight layer (membrane) supported through insulation by the adjacent hull structure.
32. **Multi-fuel engines** means engines that can use two or more different fuels that are separate from each other.
33. **Non-hazardous area** means an area in which an explosive gas atmosphere is not expected to be present in quantities such as to require special precautions for the construction, installation and use of equipment.

- 34. Open deck** means a deck having no significant fire risk that at least is open on both ends/sides, or is open on one end and is provided with adequate natural ventilation that is effective over the entire length of the deck through permanent openings distributed in the side plating or deckhead.
- 35. Risk** is an expression for the combination of the likelihood and the severity of the consequences.
- 36. Reference temperature** means the temperature corresponding to the vapour pressure of the fuel in a fuel tank at the set pressure of the pressure relief valves (PRVs).
- 37. Secondary barrier** is the liquid-resisting outer element of a fuel containment system designed to afford temporary containment of any envisaged leakage of liquid fuel through the primary barrier and to prevent the lowering of the temperature of the ship's structure to an unsafe level.
- 38. Semi-enclosed space** means a space where the natural conditions of ventilation are notably different from those on open deck due to the presence of structure such as roofs, windbreaks and bulkheads and which are so arranged that dispersion of gas may not occur. **[See Guidance]**
- 39. Source of release** means a point or location from which a gas, vapour, mist or liquid may be released into the atmosphere so that an explosive atmosphere could be formed.
- 40. Unacceptable loss of power** means that it is not possible to sustain or restore normal operation of the propulsion machinery in the event of one of the essential auxiliaries becoming inoperative, in accordance with **SOLAS regulation II-1/26.3**.
- 41. Vapour pressure** is the equilibrium pressure of the saturated vapour above the liquid, expressed in MPa absolute at a specified temperature.

### 103. Alternative design

1. This Rules contains functional requirements for all appliances and arrangements related to the usage of low-flashpoint fuels.
2. Fuels, appliances and arrangements of low-flashpoint fuel systems may either:
  - (1) deviate from those set out in this Rules, or
  - (2) be designed for use of a fuel not specifically addressed in this Rules.Such fuels, appliances and arrangements can be used provided that these meet the intent of the goal and functional requirements concerned and provide an equivalent level of safety of the relevant Chapters.
3. The equivalence of the alternative design is to be demonstrated as specified in **SOLAS regulation II-1/55** and approved by the Society. However, the Society is not to allow operational methods or procedures to be applied as an alternative to a particular fitting, material, appliance, apparatus, item of equipment, or type thereof which is prescribed by this Rules.⬇

## CHAPTER 2 GOAL AND FUNCTIONAL REQUIREMENTS

### Section 1 Goal

#### 101. Goal

The goal of this Rules is to provide for safe and environmentally-friendly design, construction and operation of ships and in particular their installations of systems for propulsion machinery, auxiliary power generation machinery and/or other purpose machinery using gas or low-flashpoint fuel as fuel.

### Section 2 Functional Requirements

#### 201. Functional requirements

1. The safety, reliability and dependability of the systems are to be equivalent to that achieved with new and comparable conventional oil-fuelled main and auxiliary machinery. **[See Guidance]**
2. The probability and consequences of fuel-related hazards are to be limited to a minimum through arrangement and system design, such as ventilation, detection and safety actions. In the event of gas leakage or failure of the risk reducing measures, necessary safety actions are to be initiated.
3. The design philosophy is to ensure that risk reducing measures and safety actions for the gas fuel installation do not lead to an unacceptable loss of power.
4. Hazardous areas are to be restricted, as far as practicable, to minimize the potential risks that might affect the safety of the ship, persons on board, and equipment.
5. Equipment installed in hazardous areas is to be minimized to that required for operational purposes and is to be suitably and appropriately certified.
6. Unintended accumulation of explosive, flammable or toxic gas concentrations is to be prevented.
7. System components are to be protected against external damages.
8. Sources of ignition in hazardous areas are to be minimized to reduce the probability of explosions.
9. It is to be arranged for safe and suitable fuel supply, storage and bunkering arrangements capable of receiving and containing the fuel in the required state without leakage. Other than when necessary for safety reasons, the system is to be designed to prevent venting under all normal operating conditions including idle periods.
10. Piping systems, containment and over-pressure relief arrangements that are of suitable design, construction and installation for their intended application are to be provided.
11. Machinery, systems and components are to be designed, constructed, installed, operated, maintained and protected to ensure safe and reliable operation.
12. Fuel containment system and machinery spaces containing source that might release gas into the space are to be arranged and located such that a fire or explosion in either will not lead to an unacceptable loss of power or render equipment in other compartments inoperable.
13. Suitable control, alarm, monitoring and shutdown systems are to be provided to ensure safe and reliable operation.
14. Fixed gas detection suitable for all spaces and areas concerned is to be arranged.
15. Fire detection, protection and extinction measures appropriate to the hazards concerned are to be provided.
16. Commissioning, trials and maintenance of fuel systems and gas utilization machinery are to satisfy the goal in terms of safety, availability and reliability.

17. The technical documentation is to permit an assessment of the compliance of the system and its components with the applicable rules, guidelines, design standards used and the principles related to safety, availability, maintainability and reliability.
18. A single failure in a technical system or component is to not lead to an unsafe or unreliable situation.↓

## CHAPTER 3 GENERAL REQUIREMENTS

### Section 1 Goal

#### 301. Goal

The goal of this Chapter is to ensure that the necessary assessments of the risks involved are carried out in order to eliminate or mitigate any adverse effect to the persons on board, the environment or the ship.

### Section 2 Risk Assessment

#### 201. Risk assessment

1. A risk assessment is to be conducted to ensure that risks arising from the use of low-flashpoint fuels affecting persons on board, the environment, the structural strength or the integrity of the ship are addressed. Consideration is to be given to the hazards associated with physical layout, operation and maintenance, following any reasonably foreseeable failure.
2. For ships using natural gas as fuel, the risk assessment required by **1** need only be conducted where explicitly required by the followings:
  - (1) **1001. 5** and **1201. 3** of **Ch 5**
  - (2) **401. 1** and **415. 4 (7) (B)** of **Ch 6**
  - (3) **301. 1** of **Ch 8**,
  - (4) **401. 1** and **701.** of **Ch 13**
  - (5) **801. 1 (10)** of **Ch 15**
  - (6) **104. 4** and **106. 8** of **Annex 2**
3. The risks are to be analysed using acceptable and recognized risk analysis techniques, and loss of function, component damage, fire, explosion and electric shock are to as a minimum be considered. The analysis is to ensure that risks are eliminated wherever possible. Risks which cannot be eliminated are to be mitigated as necessary. See **Annex 3** for detailed requirements. (2019)
4. Details of risks, and the means by which they are mitigated, are to be documented in accordance with applicable requirements in **Guidance for Approval of Risk-based Ship Design**.

### Section 3 Limitation of explosion consequences

#### 301. Limitation of explosion consequences [See Guidance]

An explosion in any space containing any potential sources of release and potential ignition sources is not to:

1. cause damage to or disrupt the proper functioning of equipment/systems located in any space other than that in which the incident occurs;
2. damage the ship in such a way that flooding of water below the main deck or any progressive flooding occur;
3. damage work areas or accommodation in such a way that persons who stay in such areas under normal operating conditions are injured;
4. disrupt the proper functioning of control stations and switchboard rooms necessary for power distribution;
5. damage life-saving equipment or associated launching arrangements;
6. disrupt the proper functioning of firefighting equipment located outside the explosion-damaged space;
7. affect other areas of the ship in such a way that chain reactions involving, inter alia, cargo, gas and bunker oil may arise; or

8. prevent persons access to life-saving appliances or impede escape routes.↓

## CHAPTER 4 CLASSIFICATION AND SURVEYS

### Section 1 General

#### 101. General

1. The classification and surveys of ships intended to be classed with the Society or classed with the Society are to be in accordance with the requirements specified in this Chapter.
2. In the case of items not specified in this Chapter, the requirements specified in **Pt 1 of Rules for the classification of steel ships** are to be applied.

### Section 2 Classification

#### 201. Class notations

Ships satisfying the requirements of this Rules may be given a notation "LFFS (dual fuel, gas only)" as additional special feature notations.

#### 202. Maintenance of classification

1. Ships classed with the Society are to be subjected to the surveys to maintain the classification and are to be maintained in good condition in accordance with the requirements specified in this Chapter.
2. Plans and particulars of any proposed alterations to the approved scantlings or arrangements of hull, machinery or equipment are to be submitted for approval by the Society before the work is commenced and such alterations are to be Surveyed by the Society.

#### 203. Classification Survey during Construction

##### 1. General

At the Classification Survey during Construction, the hull, machinery and equipment are to be examined in detail in order to ascertain that they meet the relevant requirements of this Rules.

##### 2. Plan and Documents

For a ship in which natural gas-fuelled engine installations are installed, plans and documents (triplicate for approval and 1 copy for reference), specified below **3** and **4**, are to be submitted and approved before the work is commenced. And, the Society, where considered necessary, may require further plans and documents other than those specified below.

##### 3. Plan and data for approval

- (1) Arrangement plans showing location of:
  - (A) Machinery spaces, accommodation, service and control station spaces
  - (B) Fuel containment systems
  - (C) Fuel preparation rooms
  - (D) Fuel bunkering pipes with shore connections
  - (E) Tank hatches, ventilation pipes and any other openings to the gas tanks
  - (F) Ventilating pipes, doors and openings to fuel preparation rooms and other hazardous areas
  - (G) Entrances, air inlets and openings to accommodation, service and control station spaces
  - (H) Hazardous areas of zone "0", "1" and "2"
- (2) Following plans and data of the fuel containment system:
  - (A) Drawing of gas tanks including information on non-destructive testing of welds and strength and tightness testing of tanks
  - (B) Drawings of support and staying of gas tanks
  - (C) Specification of materials in gas tanks and gas piping systems
  - (D) Specifications of welding procedures for gas tanks

- (E) Specification of stress relieving procedures for independent tanks type C (thermal or mechanical)
- (F) Specification of design loads and structural analysis of gas tanks
- (G) A complete stress analysis for gas tanks
- (H) Specification of cooling-down procedure for gas tanks
- (I) Arrangement and specifications of second barriers
- (J) Drawings and specifications of gas tank insulation
- (K) Drawing of marking plate for gas tanks
- (3) Following plans and data of piping systems:
  - (A) Drawings and specifications of gas piping including ventilation lines of safety relief valves or similar piping
  - (B) Drawings and specifications of offsets, loops, bends and mechanical expansion joints, such as bellows, slip joints(only inside tank) or similar means in the gas piping
  - (C) Drawings and specifications of flanges, valves and other fittings in the gas piping system. For valves intended for piping systems with a design temperature below - 55 °C, documentation for leak test and functional test at design temperature (type test) is required
  - (D) Complete stress analysis of piping system when design temperature is below - 110 °C
  - (E) Documentation of type tests for expansion components in the gas piping system.
  - (F) Specification of materials, welding, post-weld heat treatment and non-destructive testing of gas piping
  - (G) Specification of pressure tests (structural and tightness tests) of gas piping
  - (H) Program for functional tests of all piping systems including valves, fittings and associated equipment for handling gas (liquid or vapour)
  - (I) Drawings and specifications of insulation for low temperature piping where such insulation is installed
  - (J) Specification of electrical bonding of piping
  - (K) Specification of means for removal of liquid contents from bunkering pipes prior to disconnecting the shore connection
  - (L) Cooling or heating water system in connection with gas fuel system, if fitted.
- (4) Following plans and particulars for the safety relief valves
  - (A) Drawings and specifications for safety relief valves and pressure/vacuum relief valves and associated ventilation piping
  - (B) Calculation of required gas tank relief valve capacity, including back pressure
  - (C) Specification of procedures for changing of set pressures of cargo tank safety relief valves if such arrangements are contemplated
  - (D) Calculations for safety valves ventilation mast : location, height, details
- (5) Following plans and data for equipment and systems regarding fire protection :
  - (A) Arrangement and specification of water spray system, including pipes, valves, nozzles and fittings
  - (B) Arrangement of ventilation duct required for gas pipes lead through enclosed spaces
  - (C) Arrangement of ventilation duct for storage tank fitted below deck, if applicable
  - (D) Arrangement of fire detection system for storage tank and ventilation trunk
  - (E) Arrangement of fire insulation for storage tank and pipes, ventilation trunks for storage tank connection space
  - (F) Arrangement and specification of dry chemical powder installation.
- (6) Following plans and data for electrical installations :
  - (A) Drawings showing location of all electrical equipment in hazardous areas
  - (B) Data for verification of the compatibility between the barrier and the field component
  - (C) Single line diagram for intrinsically safe circuits
  - (D) List of explosion protected equipment
- (7) Following control and monitoring systems :
  - (A) Gas detection system
  - (B) Gas tank monitoring system
  - (C) Gas compressors control and monitoring system
  - (D) Gas engines control and monitoring system.
- (8) A test program for the safety functions of the gas installation (may be included in programme for sea trials or on-board test)
- (9) Data for a risk analysis according to **Ch 3, 201**.

#### 4. Plans and documents for reference

- (1) Plans and data of the following equipment and systems
  - (A) Drawings showing location and construction of air locks with alarm equipment, if fitted
  - (B) Drawings of gastight bulkhead penetrations, if fitted
  - (C) Arrangements and specifications of mechanical ventilation systems in spaces covering gas fuel system, giving capacity and location of fans and their motors. Drawings and material specifications of rotating parts and casings for fans and portable ventilators
  - (D) Drawings and specifications of protection of hull steel beneath liquid piping where liquid leakage may be anticipated, such as at shore connections and at pump seals
  - (E) Arrangement and specifications of piping systems for gas freeing and purging of gas tanks
  - (F) For fixed gas detection and alarm systems: specification and location of detectors, alarm devices and call points, and cable routing layout drawing
  - (G) Bilge and drainage arrangements in gas pump rooms, compressor rooms, tank connection space
  - (H) Exhaust gas system.
- (2) Calculation sheets of filling limits for fuel tanks.
- (3) Operation manual (including bunkering, gas freeing, normal operation, emergency operation).

### Section 3 Periodical Surveys

#### 301. Annal Survey

The following is to be carried out during the survey of the Fuel Storage, Fuel Bunkering System, and Fuel Supply System.

##### 1. Logbooks/Records

The logbooks and operating records are to be examined with regard to correct functioning of the gas detection systems, fuel supply/gas systems, etc. The hours per day of the reliquefaction plant, gas combustion unit, as applicable, the boil-off rate, and nitrogen consumption (for membrane containment systems) are to be considered together with gas detection records.

##### 2. Operating and Maintenance Instruction Manuals

The manufacturer/builder instructions and manuals covering the operations, safety and maintenance requirements and occupational health hazards relevant to fuel storage, fuel bunkering, and fuel supply and associated systems for the use of the fuel, are to be confirmed as being aboard the vessel.

##### 3. Control, Monitoring and Safety Systems

- (1) Gas detection and other leakage detection equipment in compartments containing fuel storage, fuel bunkering, and fuel supply equipment or components or associated systems, including indicators and alarms, is to be confirmed in satisfactory operating condition. Recalibration of the gas detection systems should be verified in accordance with the manufacturers' recommendations.
- (2) Verification of the satisfactory operation of the control, monitoring and automatic shutdown systems as far as practicable of the fuel supply and bunkering systems.
- (3) Operational test, as far as practicable, of the shutdown of ESD protected machinery spaces.

##### 4. Fuel Handling Piping, Machinery and Equipment

Piping, hoses, emergency shut-down valves, remote operating valves, relief valves, machinery and equipment for fuel storage, fuel bunkering, and fuel supply such as venting, compressing, refrigerating, liquefying, heating, cooling or otherwise handling the fuel is to be examined, as far as practicable. Means for inerting is to be examined. Stopping of pumps and compressors upon emergency shut-down of the system is to be confirmed as far as practicable.

##### 5. Ventilating System

Examination of the ventilation system, including portable ventilating equipment where fitted, is to be made for spaces containing fuel storage, fuel bunkering, and fuel supply units or components or associated systems, including air locks, pump rooms, compressor rooms, fuel preparation rooms, fuel valve rooms, control rooms and spaces containing gas burning equipment. Where alarms, such as differential pressure and loss of pressure alarms, are fitted, these should be operationally tested as far as practicable.

## 6. Drip Trays

Portable and fixed drip trays and insulation for the protection of the ship's structure in the event of leakage are to be examined.

## 7. Hazardous Areas

Electrical equipment and bulkhead/deck penetrations including access openings in hazardous areas are to be examined for continued suitability for their intended service and installation area.

## 8. Electrical Bonding

Electrical bonding arrangements in hazardous areas, including bonding straps where fitted, are to be examined.

## 9. Fuel Storage System

- (1) External examination of the storage tanks including secondary barrier if fitted and accessible
- (2) General examination of the fuel storage hold place
- (3) Internal examination of tank connection space
- (4) External examination of tank and relief valves
- (5) Verification of satisfactory operation of tank monitoring system
- (6) Examination and testing of installed bilge alarms and means of drainage of the compartment
- (7) Testing of the remote and local closing of the installed main tank valve

## 10. Fuel Bunkering System

- (1) Examination of bunkering stations and the fuel bunkering system
- (2) Verification of satisfactory operation of the fuel bunkering control, monitoring and shutdown systems

## 11. Fuel Supply System

Examination of the fuel supply system during working condition as far as practicable

- (1) Verification of satisfactory operation of the fuel supply system control, monitoring and shut-down systems.
- (2) Testing of the remote and local closing of the master fuel valve for each engine compartment.

## 302. Intermediate Survey

At the Intermediate Survey, in addition to all the requirements for Annual Survey, the following items are to be surveyed.

### 1 Safety Systems

Gas detectors, temperature sensors, pressure sensors, level indicators, and other equipment providing input to the fuel safety system are to be randomly tested to confirm satisfactory operating condition. Proper response of the fuel safety system upon fault conditions is to be verified.

## 303. Special Survey

### 1. General

The Special Survey is to include, in addition to the requirements of the Annual Survey, examination, tests and checks of sufficient extent to ensure that the fuel installations are in a satisfactory condition and is fit for its intended purpose for the new period of class of 5 years to be assigned, subject to proper maintenance and operation and to periodical surveys being carried out at the due dates.

### 2. Fuel Handling and Piping

All piping for fuel storage, fuel bunkering, and fuel supply such as venting, compressing, refrigerating, liquefying, heating storing, burning or otherwise handling the fuel and liquid nitrogen installations are to be examined. Removal of insulation from the piping and opening for examination may be required. Where deemed suspect, a hydrostatic test to 1.25 times the Maximum Allowable Relief Valve Setting (MARVS) for the pipeline is to be carried out. After reassembly, the complete piping is to be tested for leaks. Where water cannot be tolerated and the piping cannot be dried prior to putting the system into service, the Surveyor may accept alternative testing fluids or alternative means of testing.

### 3. Fuel Valves

Fuel valves in (1) and (2) are to be examined and proven operable. A random selection of valves is to be opened for examination.

- (1) Emergency shut-down valves, check valves, block and bleed valves, master gas valves, remote operating valves,
- (2) Isolating valves for pressure relief valves in the fuel storage, fuel bunkering, and fuel supply piping systems are to be examined and proven operable.

### 4. Pressure Relief Valves

- (1) Fuel Storage Tank Pressure Relief Valves

The pressure relief valves for the fuel storage tanks are to be opened for examination, adjusted, and function tested. If the tanks are equipped with relief valves with non-metallic membranes in the main or pilot valves, such non-metallic membranes are to be replaced.

- (2) Fuel Supply and Bunkering Piping Pressure Relief Valves

Pressure relief valves for the fuel supply and bunkering piping are to be opened for examination, adjusted, and function tested. Where a proper record of continuous overhaul and retesting of individually identifiable relief valves is maintained, consideration will be given to acceptance on the basis of opening, internal examination, and testing of a representative sampling of valves, including each size and type of liquefied gas or vapor relief valve in use, provided there is log-book evidence that the remaining valves have been overhauled and tested since crediting of the previous Special Survey. (2019)

- (3) Pressure/Vacuum Relief Valves

The pressure/vacuum relief valves, rupture disc and other pressure relief devices for interbarrier spaces and hold spaces are to be opened, examined, tested and readjusted as necessary, depending on their design.

### 5. Fuel Handling Equipment

Fuel pumps, compressors, process pressure vessels, inert gas generators, heat exchangers and other components used in connection with fuel handling are to be examined as required in the **Rules for the classification of steel ships**.

### 6. Electrical Equipment

- (1) Examination of electrical equipment to include the physical condition of electrical cables and supports, intrinsically safe, explosion proof, or increased safety features of electrical equipment.
- (2) Functional testing of pressurized equipment and associated alarms.
- (3) Testing of systems for de-energizing electrical equipment which is not certified for use in hazardous areas.
- (4) An electrical insulation resistance test of the circuits terminating in, or passing through, the hazardous zones and spaces is to be carried out.

### 7. Safety Systems

Gas detectors, temperature sensors, pressure sensors, level indicators, and other equipment providing input to the fuel safety system are to be tested to confirm satisfactory operating condition.

- (1) Proper response of the fuel safety system upon fault conditions is to be verified.
- (2) Pressure, temperature and level indicating equipment are to be calibrated in accordance with the manufacturer's requirements.

### 8. Fuel Storage Tanks [See Guidance]

Fuel storage tanks are to be examined in accordance with an approved survey plan. Liquefied gas fuel storage tanks are to be examined based upon Guidance. ↓

# CHAPTER 5 SHIP DESIGN AND ARRANGEMENT

## Section 1 General

### 101. Goal

The goal of this Chapter is to provide for safe location, space arrangements and mechanical protection of power generation equipment, fuel storage systems, fuel supply equipment and refuelling systems.

## Section 2 Functional Requirements

### 201. Functional requirements

This Chapter is related to functional requirements in Ch 2, 201. 1~3, 5, 6, 8, 12~15 and 17. In particular the following apply:

1. the fuel tank is to be located in such a way that the probability for the tank to be damaged following a collision or grounding is reduced to a minimum taking into account the safe operation of the ship and other hazards that may be relevant to the ship;
2. fuel containment systems, fuel piping and other fuel sources of release are to be so located and arranged that released gas is lead to a safe location in the open air;
3. the access or other openings to spaces containing fuel sources of release is to be so arranged that flammable, asphyxiating or toxic gas cannot escape to spaces that are not designed for the presence of such gases
4. fuel piping is to be protected against mechanical damage;
5. the propulsion and fuel supply system is to be so designed that safety actions after any gas leakage do not lead to an unacceptable loss of power; and
6. the probability of a gas explosion in a machinery space with gas or low-flashpoint fuelled machinery is to be minimized.

## Section 3 Arrangement of Fuel Tanks

### 301. General requirements

1. Fuel storage tanks are to be protected against mechanical damage.
2. Fuel storage tanks and equipment located on open deck are to be located to ensure sufficient natural ventilation, so as to prevent accumulation of escaped gas.

### 302. Location of fuel tanks

1. The fuel tanks are to be protected from external damage caused by collision or grounding in the following way(see Fig 5.1):
  - (1) The fuel tanks are to be located at a minimum distance of  $B/5$  or 11.5 m, whichever is less, measured inboard from the ship side at right angles to the centreline at the level of the summer load line draught;
  - (2) The boundaries of each fuel tank are to be taken as the extreme outer longitudinal, transverse and vertical limits of the tank structure including its tank valves.
  - (3) For independent tanks the protective distance is to be measured to the tank shell (the primary barrier of the tank containment system). For membrane tanks the distance is to be measured to the bulkheads surrounding the tank insulation..
  - (4) In no case is the boundary of the fuel tank to be located closer to the shell plating or aft terminal of the ship than as follows:

- (A) For passenger ships:  
 $B/10$  but in no case less than 0.8 m. However, this distance need not be greater than  $B/15$  or 2 m whichever is less where the shell plating is located inboard of  $B/5$  or 11.5 m, whichever is less, as required by (1).
- (B) For cargo ships:  
 (a) for  $V_c \leq 1,000 \text{ m}^3$ , 0.8 m;  
 (b) for  $1,000 \text{ m}^3 < V_c < 5,000 \text{ m}^3$ ,  $0.75 + V_c \times 0.2/4,000$  m;  
 (c) for  $5,000 \text{ m}^3 \leq V_c < 30,000 \text{ m}^3$ ,  $0.8 + V_c/25,000$  m; and  
 (d) for  $V_c \geq 30,000 \text{ m}^3$ , 2 m,

where:

$V_c$  : corresponds to 100 % of the gross design volume of the individual fuel tank at 20 °C, including domes and appendages.

- (5) The lowermost boundary of the fuel tanks is to be located above the minimum distance of  $B/15$  or 2.0 m, whichever is less, measured from the moulded line of the bottom shell plating at the centreline.
- (6) For multihull ships the value of B may be specially considered.
- (7) The fuel tank is to be abaft a transverse plane at 0.08L measured from the forward perpendicular in accordance with **SOLAS II-1/8.1** for passenger ships, and abaft the collision bulkhead for cargo ships.
- (8) For ships with a hull structure providing higher collision and/or grounding resistance, fuel tank location regulations may be specially considered in accordance with **Ch 1, 103.**

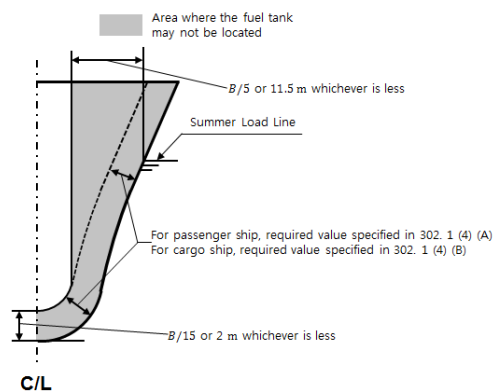

**Fig 5.1 Location of Fuel Tank**

2. As an alternative to 1 (1) above, the following calculation method may be used to determine the acceptable location of the fuel tanks:

- (1) The value  $f_{CN}$  calculated as described in the following is to be less than 0.02 for passenger ships and 0.04 for cargo ships.

The value  $f_{CN}$  accounts for collision damages that may occur within a zone limited by the longitudinal projected boundaries of the fuel tank only, and cannot be considered or used as the probability for the fuel tank to become damaged given a collision. The real probability will be higher when accounting for longer damages that include zones forward and aft of the fuel tank.

- (2) The  $f_{CN}$  is calculated by the following formulation:

$$f_{CN} = f_l \times f_t \times f_v$$

where:

$f_l$  = the calculated value by use of the formulations for factor  $p$  contained in **SOLAS II-1/7-1.1.1.1**. The value of  $x_1$  is to correspond to the distance from the aft terminal to the aftmost boundary of the fuel tank and the value of  $x_2$  is to correspond to the distance from the aft terminal to the foremost boundary of the fuel tank.

$f_t$  = the calculated value by use of the formulations for factor  $r$  contained in **SOLAS**

**II-1/7-1.1.2**, and reflects the probability that the damage penetrates beyond the outer boundary of the fuel tank. The formulation is:

$$f_t = 1 - r(x_1, x_2, b)$$

When the outermost boundary of the fuel tank is outside the boundary given by the deepest subdivision waterline the value of  $b$  is to be taken as 0.

$f_v$  = the calculated value by use of the formulations for factor  $v$  contained in **SOLAS II-1/7-2.6.1.1** and reflects the probability that the damage is not extending vertically above the lowermost boundary of the fuel tank. The formulations to be used are:

$f_v = 1.0 - 0.8 \cdot \frac{(H-d)}{7.8}$ , if  $(H-d)$  is less than or equal to 7.8 m,  $f_v$  is not to be taken greater than 1.

$f_v = 0.2 - 0.2 \cdot \frac{(H-d) - 7.8}{4.7}$ , in all other cases  $f_v$  is not to be taken less than 0.

where:

$H$  is the distance from baseline, in metres, to the lowermost boundary of the fuel tank; and

$d$  is the deepest draught (summer load line draught).

- (3) The boundaries of each fuel tank are to be taken as the extreme outer longitudinal, transverse and vertical limits of the tank structure including its tank valves.
- (4) For independent tanks the protective distance is to be measured to the tank shell (the primary barrier of the tank containment system). For membrane tanks the distance is to be measured to the bulkheads surrounding the tank insulation.
- (5) In no case is the boundary of the fuel tank to be located closer to the shell plating or aft terminal of the ship than as follows:
  - (A) For passenger ships:  
B/10 but in no case less than 0.8 m. However, this distance need not be greater than B/15 or 2 m whichever is less where the shell plating is located inboard of B/5 or 11.5 m, whichever is less, as required by **1 (1)**.
  - (B) For cargo ships:
    - (a) for  $V_c \leq 1,000 \text{ m}^3$ , 0.8 m;
    - (b) for  $1,000 \text{ m}^3 < V_c < 5,000 \text{ m}^3$ ,  $0.75 + V_c \times 0.2/4,000$  m;
    - (c) for  $5,000 \text{ m}^3 \leq V_c < 30,000 \text{ m}^3$ ,  $0.8 + V_c/25,000$  m; and
    - (d) for  $V_c \geq 30,000 \text{ m}^3$ , 2 m,

where:

$V_c$  : corresponds to 100 % of the gross design volume of the individual fuel tank at 20 °C, including domes and appendages.

- (6) In case of more than one non-overlapping fuel tank located in the longitudinal direction,  $f_{CN}$  is to be calculated in accordance with (2) for each fuel tank separately. The value used for the complete fuel tank arrangement is the sum of all values for  $f_{CN}$  obtained for each separate tank.
  - (7) In case the fuel tank arrangement is unsymmetrical about the centreline of the ship, the calculations of  $f_{CN}$  is to be calculated on both starboard and port side and the average value is to be used for the assessment. The minimum distance as set forth in (5) is to be met on both sides.
  - (8) For ships with a hull structure providing higher collision and/or grounding resistance, fuel tank location regulations may be specially considered in accordance with **Ch 1, 103**.
- 3.** When fuel is carried in a fuel containment system requiring a complete or partial secondary barrier:
- (1) fuel storage hold spaces are to be segregated from the sea by a double bottom; and
  - (2) the ship is to also have a longitudinal bulkhead forming side tanks.

## Section 4 Machinery Space Concepts

### 401. Machinery space concepts [See Guidance]

In order to minimize the probability of a gas explosion in a machinery space with gas-fuelled machinery one of these two alternative concepts may be applied:

1. Gas safe machinery spaces: Arrangements in machinery spaces are such that the spaces are considered gas safe under all conditions, normal as well as abnormal conditions, i.e. inherently gas safe. In a gas safe machinery space a single failure cannot lead to release of fuel gas into the machinery space.
2. ESD-protected machinery spaces: Arrangements in machinery spaces are such that the spaces are considered non-hazardous under normal conditions, but under certain abnormal conditions may have the potential to become hazardous. In the event of abnormal conditions involving gas hazards, emergency shutdown (ESD) of non-safe equipment (ignition sources) and machinery is to be automatically executed while equipment or machinery in use or active during these conditions are to be of a certified safe type. In an ESD protected machinery space a single failure may result in a gas release into the space. Venting is designed to accommodate a probable maximum leakage scenario due to technical failures. Failures leading to dangerous gas concentrations, e.g. gas pipe ruptures or blow out of gaskets are covered by explosion pressure relief devices and ESD arrangements.

## Section 5 Gas Safe Machinery Space

### 501. Gas safe machinery space

1. A single failure within the fuel system is not to lead to a gas release into the machinery space.
2. All fuel piping within machinery space boundaries is to be enclosed in a gas tight enclosure in accordance with **Ch 9, 601..**

## Section 6 ESD-Protected Machinery Spaces

### 601. ESD-protected machinery spaces

1. ESD protection is to be limited to machinery spaces that are certified for periodically unattended operation.
2. Measures are to be applied to protect against explosion, damage of areas outside of the machinery space and ensure redundancy of power supply. The following arrangement is to be provided but may not be limited to:
  - (1) gas detector;
  - (2) shutoff valve;
  - (3) redundancy; and
  - (4) efficient ventilation.
3. Gas supply piping within machinery spaces may be accepted without a gastight external enclosure on the following conditions:
  - (1) Engines for generating propulsion power and electric power are to be located in two or more machinery spaces not having any common boundaries unless it can be documented that a single casualty will not affect both spaces.
  - (2) The gas machinery space is to contain only a minimum of such necessary equipment, components and systems as are required to ensure that the gas machinery maintains its function.
  - (3) A fixed gas detection system arranged to automatically shutdown the gas supply, and disconnect all electrical equipment or installations not of a certified safe type, is to be fitted.
4. Distribution of engines between the different machinery spaces is to be such that shutdown of fuel supply to any one machinery space does not lead to an unacceptable loss of power.

5. ESD protected machinery spaces separated by a single bulkhead are to have sufficient strength to withstand the effects of a local gas explosion in either space, without affecting the integrity of the adjacent space and equipment within that space.
6. ESD protected machinery spaces are to be designed to provide a geometrical shape that will minimize the accumulation of gases or formation of gas pockets.
7. The ventilation system of ESD-protected machinery spaces is to be arranged in accordance with **Ch 13, 501..**

## **Section 7 Location and protection of fuel piping**

### **701. Location and protection of fuel piping**

1. Fuel pipes are to not be located less than 800 mm from the ship's side.
2. Fuel piping is to not be led directly through accommodation spaces, service spaces, electrical equipment rooms or control stations as defined in the SOLAS Convention. **[See Guidance]**
3. Fuel pipes led through ro-ro spaces, special category spaces and on open decks are to be protected against mechanical damage.
4. Gas fuel piping in ESD protected machinery spaces is to be located as far as practicable from the electrical installations and tanks containing flammable liquids.
5. Gas fuel piping in ESD protected machinery spaces is to be protected against mechanical damage.

## **Section 8 Fuel Preparation Room**

### **801. Fuel preparation room [See Guidance]**

Fuel preparation rooms are to be located on an open deck, unless those rooms are arranged and fitted in accordance with the regulations of this Rules for tank connection spaces.

## **Section 9 Bilge Systems**

### **901. Bilge systems**

1. Bilge systems installed in areas where fuel covered by this Rules can be present are to be segregated from the bilge system of spaces where fuel cannot be present.
2. Where fuel is carried in a fuel containment system requiring a secondary barrier, suitable drainage arrangements for dealing with any leakage into the hold or insulation spaces through the adjacent ship structure are to be provided. The bilge system is to not lead to pumps in safe spaces. Means of detecting such leakage are to be provided.
3. The hold or interbarrier spaces of type A independent tanks for liquid gas are to be provided with a drainage system suitable for handling liquid fuel in the event of fuel tank leakage or rupture.

## **Section 10 Drip Trays**

### **1001. Drip trays**

1. Drip trays are to be fitted where leakage may occur which can cause damage to the ship structure or where limitation of the area which is effected from a spill is necessary.
2. Drip trays are to be made of suitable material.
3. The drip tray is to be thermally insulated from the ship's structure so that the surrounding hull or deck structures are not exposed to unacceptable cooling, in case of leakage of liquid fuel.

4. Each tray is to be fitted with a drain valve to enable rain water to be drained over the ship's side.
5. Each tray is to have a sufficient capacity to ensure that the maximum amount of spill according to the risk assessment can be handled.

## Section 11 Arrangement of Entrances and Other Openings in Enclosed Spaces

### 1101. Arrangement of entrances and other openings in enclosed spaces

1. Direct access is not to be permitted from a non-hazardous area to a hazardous area. Where such openings are necessary for operational reasons, an airlock which complies with **1201.** is to be provided.
2. If the fuel preparation room is approved located below deck, the room is to, as far as practicable, have an independent access direct from the open deck. Where a separate access from deck is not practicable, an airlock which complies with **1201.** is to be provided.
3. Unless access to the tank connection space is independent and direct from open deck it is to be arranged as a bolted hatch. The space containing the bolted hatch will be a hazardous space.
4. If the access to an ESD-protected machinery space is from another enclosed space in the ship, the entrances are to be arranged with an airlock which complies with **1201.**
5. For inerted spaces access arrangements are to be such that unintended entry by personnel is to be prevented. If access to such spaces is not from an open deck, sealing arrangements are to ensure that leakages of inert gas to adjacent spaces are prevented.

## Section 12 Airlocks

### 1201. Airlocks

1. An airlock is a space enclosed by gastight bulkheads with two substantially gastight doors spaced at least 1.5 m and not more than 2.5 m apart. Unless subject to the requirements of the International Convention on Load Lines, the door sill is to not be less than 300 mm in height. The doors are to be self-closing without any holding back arrangements.
2. Airlocks are to be mechanically ventilated at an overpressure relative to the adjacent hazardous area or space. The ventilating fans for air-lock space and their air intakes are to be provided in the gas-safe space. In this case, the ventilating fans may not comply with the requirements in **Ch 13, 303. 1.** Protection screens of not more than 13 mm × 13 mm square mesh are to be fitted in outside openings of ventilation ducts.
3. The airlock is to be designed in a way that no gas can be released to safe spaces in case of the most critical event in the gas dangerous space separated by the airlock. The events are to be evaluated in the risk analysis according to **Ch 3, 201.**
4. Airlocks are to have a simple geometrical form. They are to provide free and easy passage, and are to have a deck area not less than 1.5 m<sup>2</sup>. Airlocks are to not be used for other purposes, for instance as store rooms.
5. An audible and visual alarm system to give a warning on both sides of the airlock is to be provided to indicate if more than one door is moved from the closed position.
6. For non-hazardous spaces with access from hazardous spaces below deck where the access is protected by an airlock, upon loss of underpressure in the hazardous space access to the space is to be restricted until the ventilation has been reinstated. Audible and visual alarms are to be given at a manned location to indicate both loss of pressure and opening of the airlock doors when pressure is lost.
7. Essential equipment required for safety is not to be de-energized and is to be of a certified safe type. This may include lighting, fire detection, public address, general alarms systems. ⚡

## CHAPTER 6 FUEL CONTAINMENT SYSTEM

### Section 1 General

#### 101. Goal

The goal of this chapter is to provide that gas storage is adequate so as to minimize the risk to personnel, the ship and the environment to a level that is equivalent to a conventional oil fuelled ship.

### Section 2 Functional Requirements

#### 201. Functional requirements

This chapter relates to functional requirements in **Ch 2 201. 1, 2, 5 and 8 to 17** In particular the following apply:

1. the fuel containment system is to be so designed that a leak from the tank or its connections does not endanger the ship, persons on board or the environment. Potential dangers to be avoided include:
  - (1) exposure of ship materials to temperatures below acceptable limits;
  - (2) flammable fuels spreading to locations with ignition sources;
  - (3) toxicity potential and risk of oxygen deficiency due to fuels and inert gases;
  - (4) restriction of access to muster stations, escape routes and life-saving appliances (LSA); and
  - (5) reduction in availability of LSA.
2. the pressure and temperature in the fuel tank are to be kept within the design limits of the containment system and possible carriage requirements of the fuel;
3. the fuel containment arrangement is to be so designed that safety actions after any gas leakage do not lead to an unacceptable loss of power; and
4. if portable tanks are used for fuel storage, the design of the fuel containment system is to be equivalent to permanent installed tanks as described in this chapter.

### Section 3 General Requirements

#### 301. General requirements

1. Natural gas in a liquid state may be stored with a maximum allowable relief valve setting (MARVS) of up to 1.0 MPa.
2. The Maximum Allowable Working Pressure (MAWP) of the gas fuel tank is not to exceed 90 % of the Maximum Allowable Relief Valve Setting (MARVS).
3. A fuel containment system located below deck is to be gas tight towards adjacent spaces.
4. All tank connections, fittings, flanges and tank valves must be enclosed in gas tight tank connection spaces, unless the tank connections are on open deck. The space is to be able to safely contain leakage from the tank in case of leakage from the tank connections.
5. Pipe connections to the fuel storage tank are to be mounted above the highest liquid level in the tanks, except for fuel storage tanks of type C. Connections below the highest liquid level may however also be accepted for other tank types after special consideration by the Society.  
[See Guidance]
6. Piping between the tank and the first valve which release liquid in case of pipe failure is to have equivalent safety as the type C tank, with dynamic stress not exceeding the values given in **Ch 6 415. 3 (1) (B)**.
7. The material of the bulkheads of the tank connection space is to have a design temperature corre-

sponding with the lowest temperature it can be subject to in a probable maximum leakage scenario. The tank connection space is to be designed to withstand the maximum pressure build up during such a leakage. Alternatively, pressure relief venting to a safe location (mast) can be provided.

8. The probable maximum leakage into the tank connection space is to be determined based on detail design, detection and shutdown systems.
9. If piping is connected below the liquid level of the tank it has to be protected by a secondary barrier up to the first valve.
10. If liquefied gas fuel storage tanks are located on open deck the ship steel is to be protected from potential leakages from tank connections and other sources of leakage by use of drip trays. The material is to have a design temperature corresponding to the temperature of the fuel carried at atmospheric pressure. The normal operation pressure of the tanks is to be taken into consideration for protecting the steel structure of the ship. **[See Guidance]**
11. Means is to be provided whereby liquefied gas in the storage tanks can be safely emptied.
12. It is to be possible to empty, purge and vent fuel storage tanks with fuel piping systems. Instructions for carrying out these procedures must be available on board. Inerting is to be performed with an inert gas prior to venting with dry air to avoid an explosion hazardous atmosphere in tanks and fuel pipes. See detailed regulations venting with dry air to avoid an explosion hazardous atmosphere in tanks and fuel pipes. See detailed regulations in **1001**.

## Section 4 Liquefied gas fuel containment

### 401. General

1. The risk assessment required in **Ch 3, 201**. is to include evaluation of the ship's liquefied gas fuel containment system, and may lead to additional safety measures for integration into the overall vessel design.
2. The design life of fixed liquefied gas fuel containment system is not to be less than the design life of the ship or 20 years, whichever is greater.
3. The design life of portable tanks is not to be less than 20 years.
4. Liquefied gas fuel containment systems is to be designed in accordance with North Atlantic environmental conditions and relevant long-term sea state scatter diagrams for unrestricted navigation. Less demanding environmental conditions, consistent with the expected usage, may be accepted by the Society for liquefied gas fuel containment systems used exclusively for restricted navigation. More demanding environmental conditions may be required for liquefied gas fuel containment systems operated in conditions more severe than the North Atlantic environment. (Refer to the **Pt 3, Annex 3-2 of Guidance relating to the Rules for the Classification of Steel Ships**. Assumed temperatures are used for determining appropriate material qualities with respect to design temperatures and is another matter not intended to be covered in this article.)
5. Liquefied gas fuel containment systems is to be designed with suitable safety margins:
  - (1) to withstand, in the intact condition, the environmental conditions anticipated for the liquefied gas fuel containment system's design life and the loading conditions appropriate for them, which is to include full homogeneous and partial load conditions and partial filling to any intermediate levels; and
  - (2) being appropriate for uncertainties in loads, structural modelling, fatigue, corrosion, thermal effects, material variability, aging and construction tolerances.
6. The liquefied gas fuel containment system structural strength is to be assessed against failure modes, including but not limited to plastic deformation, buckling and fatigue. The specific design conditions that is to be considered for the design of each liquefied gas fuel containment system are given in **415**. There are three main categories of design conditions:
  - (1) Ultimate Design Conditions –. The liquefied gas fuel containment system structure and its structural components is to withstand loads liable to occur during its construction, testing and anticipated use in service, without loss of structural integrity. The design is to take into account proper combinations of the following loads:

- (A) internal pressure;
  - (B) external pressure;
  - (C) dynamic loads due to the motion of the ship in all loading conditions;
  - (D) thermal loads;
  - (E) sloshing loads;
  - (F) loads corresponding to ship deflections;
  - (G) tank and liquefied gas fuel weight with the corresponding reaction in way of supports;
  - (H) insulation weight;
  - (I) loads in way of towers and other attachments; and
  - (J) test loads.
- (2) Fatigue Design Conditions – The liquefied gas fuel containment system structure and its structural components are not to fail under accumulated cyclic loading.
- (3) Accidental Design Conditions – The liquefied gas fuel containment system is to meet each of the following accident design conditions (accidental or abnormal events), addressed in this Rules:
- (A) Collision –. The liquefied gas fuel containment system is to withstand the collision loads specified in **409. 5** (1) without deformation of the supports or the tank structure in way of the supports likely to endanger the tank and its supporting structure.
  - (B) Fire –. The liquefied gas fuel containment systems is to sustain without rupture the rise in internal pressure specified in **703. 1** under the fire scenarios envisaged therein.
  - (C) Flooded compartment causing buoyancy on tank –. the anti-flotation arrangements is to sustain the upward force, specified in **409. 5** (2) and there is to be no endangering plastic deformation to the hull. Plastic deformation may occur in the fuel containment system provided it does not endanger the safe evacuation of the ship.
7. Measures are to be applied to ensure that scantlings required meet the structural strength provisions and are maintained throughout the design life. Measures may include, but are not limited to, material selection, coatings, corrosion additions, cathodic protection and inerting.
8. An inspection/survey plan for the liquefied gas fuel containment system is to be developed and approved by the Society. The inspection/survey plan is to identify aspects to be examined and/or validated during surveys throughout the liquefied gas fuel containment system's life and, in particular, any necessary in-service survey, maintenance and testing that was assumed when selecting liquefied gas fuel containment system design parameters. The inspection/survey plan may include specific critical locations as per **412. 2** (8) or **412. 2** (9).
9. Liquefied gas fuel containment systems is to be designed, constructed and equipped to provide adequate means of access to areas that need inspection as specified in the inspection/survey plan. Liquefied gas fuel containment systems, including all associated internal equipment is to be designed and built to ensure safety during operations, inspection and maintenance.

#### 402. Liquefied gas fuel containment safety principles

1. The containment systems is to be provided with a complete secondary liquid-tight barrier capable of safely containing all potential leakages through the primary barrier and, in conjunction with the thermal insulation system, of preventing lowering of the temperature of the ship structure to an unsafe level.
2. The size and configuration or arrangement of the secondary barrier may be reduced or omitted where an equivalent level of safety can be demonstrated in accordance with **3** to **5** as applicable.
3. Liquefied gas fuel containment systems for which the probability for structural failures to develop into a critical state has been determined to be extremely low but where the possibility of leakages through the primary barrier cannot be excluded, is to be equipped with a partial secondary barrier and small leak protection system capable of safely handling and disposing of the leakages (a critical state means that the crack develops into unstable condition).  
The arrangements is to comply with the following:
  - (1) failure developments that can be reliably detected before reaching a critical state (e.g. by gas detection or inspection) is to have a sufficiently long development time for remedial actions to be taken; and
  - (2) failure developments that cannot be safely detected before reaching a critical state is to have a predicted development time that is much longer than the expected lifetime of the tank.
4. No secondary barrier is required for liquefied gas fuel containment systems, e.g. type C independent

tanks, where the probability for structural failures and leakages through the primary barrier is extremely low and can be neglected.

- For independent tanks requiring full or partial secondary barrier, means for safely disposing of leakages from the tank is to be arranged.

#### 403. Secondary barriers in relation to tank types

Secondary barriers in relation to the tank types defined in 415. is to be provided in accordance with the following table.

**Table 6.1 Secondary barrier in relation to the Tank type**

Basic Tank type	Secondary barrier requirements
Membrane	Complete secondary barrier
Independent	
Type A	Complete secondary barrier
Type B	Partial secondary barrier
Type C	No secondary barrier required

#### 404. Design of secondary barriers [See Guidance]

The design of the secondary barrier, including spray shield if fitted, is to be such that:

- it is capable of containing any envisaged leakage of liquefied gas fuel for a period of 15 days unless different criteria apply for particular voyages, taking into account the load spectrum referred to in 412. 2. (6). [See Guidance]
- physical, mechanical or operational events within the liquefied gas fuel tank that could cause failure of the primary barrier is not to impair the due function of the secondary barrier, or vice versa;
- failure of a support or an attachment to the hull structure will not lead to loss of liquid tightness of both the primary and secondary barriers;
- it is capable of being periodically checked for its effectiveness by means of a visual inspection or other suitable means acceptable to the Society; [See Guidance]
- the methods required in (4) are to be approved by the Society and are to include, as a minimum:
  - details on the size of defect acceptable and the location within the secondary barrier, before its liquid tight effectiveness is compromised;
  - accuracy and range of values of the proposed method for detecting defects in (A) above;
  - scaling factors to be used in determining the acceptance criteria if full-scale model testing is not undertaken; and
  - effects of thermal and mechanical cyclic loading on the effectiveness of the proposed test.
- the secondary barrier is to fulfil its functional requirements at a static angle of heel of 30°.

#### 405. Partial secondary barriers and primary barrier small leak protection system [See Guidance]

- Partial secondary barriers as permitted in 402. 3 is to be used with a small leak protection system and meet all the regulations in 404. The small leak protection system is to include means to detect a leak in the primary barrier, provision such as a spray shield to deflect any liquefied gas fuel down into the partial secondary barrier, and means to dispose of the liquid, which may be by natural evaporation. [See Guidance]
- The capacity of the partial secondary barrier is to be determined, based on the liquefied gas fuel leakage corresponding to the extent of failure resulting from the load spectrum referred to in 412. 2. (6), after the initial detection of a primary leak. Due account may be taken of liquid evaporation, rate of leakage, pumping capacity and other relevant factors.
- The required liquid leakage detection may be by means of liquid sensors, or by an effective use of pressure, temperature or gas detection systems, or any combination thereof.

4. For independent tanks for which the geometry does not present obvious locations for leakage to collect, the partial secondary barrier is to also fulfil its functional requirements at a nominal static angle of trim.

#### 406. Supporting arrangements [See Guidance]

1. The liquefied gas fuel tanks is to be supported by the hull in a manner that prevents bodily movement of the tank under the static and dynamic loads defined in **409. 2** to **5**, where applicable, while allowing contraction and expansion of the tank under temperature variations and hull deflections without undue stressing of the tank and the hull.
2. Anti-flotation arrangements is to be provided for independent tanks and capable of withstanding the loads defined in **409. 5** (2) without plastic deformation likely to endanger the hull structure.
3. Supports and supporting arrangements are to withstand the loads defined in **409. 3** (3) (H) and **409. 5**, but these loads need not be combined with each other or with wave-induced loads.

#### 407. Associated structure and equipment

Liquefied gas fuel containment systems are to be designed for the loads imposed by associated structure and equipment. This includes pump towers, liquefied gas fuel domes, liquefied gas fuel pumps and piping, stripping pumps and piping, nitrogen piping, access hatches, ladders, piping penetrations, liquid level gauges, independent level alarm gauges, spray nozzles, and instrumentation systems (such as pressure, temperature and strain gauges).

#### 408. Thermal insulation [See Guidance]

Thermal insulation is to be provided as required to protect the hull from temperatures below those allowable (see **413. 1** (1)) and limit the heat flux into the tank to the levels that can be maintained by the pressure and temperature control system applied in **Sec 9**.

#### 409. Design loads

##### 1. General

- (1) This section defines the design loads that is to be considered with regard to regulations in **410**. to **412**. This includes load categories (permanent, functional, environmental and accidental) and the description of the loads.
- (2) The extent to which these loads is to be considered depends on the type of tank, and is more fully detailed in the following **2** to **5**.
- (3) Tanks, together with their supporting structure and other fixtures, are to be designed taking into account relevant combinations of the loads described below.

##### 2. Permanent loads

- (1) Gravity loads  
The weight of tank, thermal insulation, loads caused by towers and other attachments are to be considered.
- (2) Permanent external loads  
Gravity loads of structures and equipment acting externally on the tank are to be considered.

##### 3. Functional loads

- (1) Loads arising from the operational use of the tank system are to be classified as functional loads.
- (2) All functional loads that are essential for ensuring the integrity of the tank system, during all design conditions, are to be considered.
- (3) As a minimum, the effects from the following criteria, as applicable, are to be considered when establishing functional loads:
  - internal pressure/
  - external pressure/
  - thermally induced loads/
  - vibration/
  - interaction loads/

loads associated with construction and installation/  
 test loads/  
 static heel loads/  
 weight of liquefied gas fuel/  
 sloshing/  
 wind impact, wave impacts and green sea effect for tanks installed on open deck.

(A) Internal pressure

- (a) In all cases, including (b),  $P_0$  is not to be less than MARVS.
- (b) For liquefied gas fuel tanks where there is no temperature control and where the pressure of the liquefied gas fuel is dictated only by the ambient temperature,  $P_0$  is not to be less than the gauge vapour pressure of the liquefied gas fuel at a temperature of 45 °C except as follows:
- (i) Lower values of ambient temperature may be accepted by the Society for ships operating in restricted areas. Conversely, higher values of ambient temperature may be required.
- (ii) For ships on voyages of restricted duration,  $P_0$  may be calculated based on the actual pressure rise during the voyage and account may be taken of any thermal insulation of the tank.
- (c) Subject to special consideration by the Society and to the limitations given in **415**, for the various tank types, a vapour pressure  $P_h$  higher than  $P_0$  may be accepted for site specific conditions (harbour or other locations), where dynamic loads are reduced.
- (d) Pressure used for determining the internal pressure is to be:
- (i)  $(P_{gd})_{\max}$  is the associated liquid pressure determined using the maximum design accelerations.
- (ii)  $(P_{gd\ site})_{\max}$  is the associated liquid pressure determined using site specific accelerations.
- (iii)  $P_{eq}$  is to be the greater of  $P_{eq\ 1}$  and  $P_{eq\ 2}$  calculated as follows:

$$P_{eq\ 1} = P_0 + (P_{gd})_{\max} \quad (\text{MPa})$$

$$P_{eq\ 2} = P_h + (P_{gd\ site})_{\max} \quad (\text{MPa})$$

- (e) The internal liquid pressures are those created by the resulting acceleration of the centre of gravity of the liquefied gas fuel due to the motions of the ship referred to in **409. 4 (1) (A)**. The value of internal liquid pressure  $P_{gd}$  resulting from combined effects of gravity and dynamic accelerations is to be calculated as follows:

$$P_{gd} = a_{\beta} Z_{\beta} \frac{\rho}{1.02 \times 10^5} \quad (\text{MPa})$$

where:

$a_{\beta}$  : dimensionless acceleration (i.e. relative to the acceleration of gravity), resulting from gravitational and dynamic loads, in an arbitrary direction  $\beta$  (see **Fig 6.1**). For large tanks, an acceleration ellipsoid, taking account of transverse vertical and longitudinal accelerations, is to be used.

$Z_{\beta}$  : largest liquid height (m) above the point where the pressure is to be determined measured from the tank shell in the  $\beta$  direction (see **Fig 6.2**).

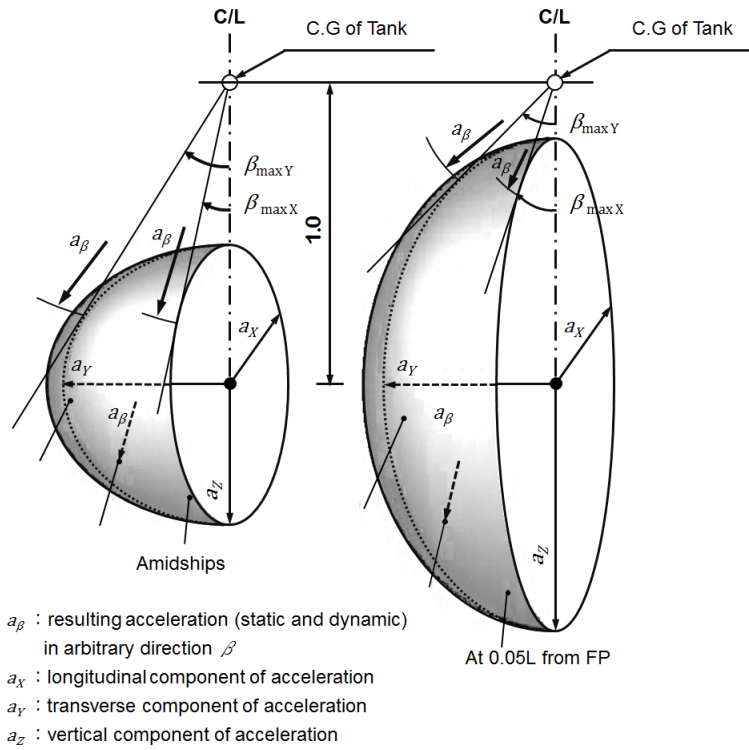

Fig 6.1 Acceleration ellipsoid

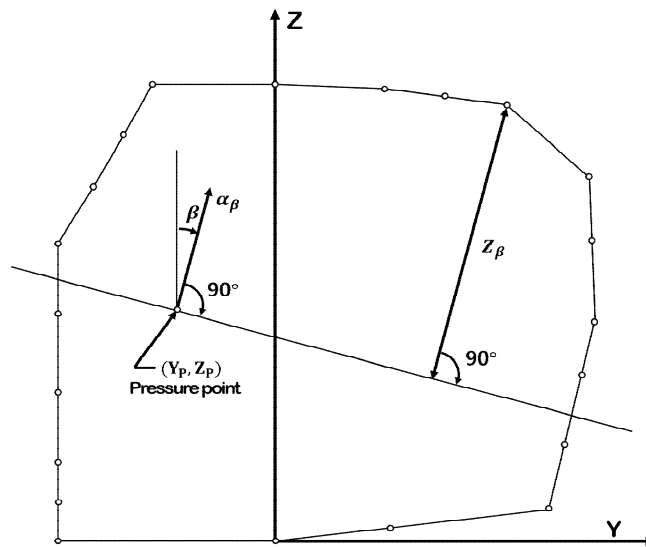

Fig 6.2 Determination of internal pressure heads

Tank domes considered to be part of the accepted total tank volume are to be taken into account when determining  $Z_\beta$  unless the total volume of tank domes  $V_d$  does not exceed the following value:

$$V_d = V_t \left( \frac{100 - FL}{FL} \right)$$

where:

$V_t$  = tank volume without any domes; and

$FL$  = filling limit according to **801**.

$\rho$  = maximum liquefied gas fuel density ( $\text{kg/m}^3$ ) at the design temperature.

The direction that gives the maximum value  $(P_{gd})_{\text{max}}$  or  $(P_{gd,site})_{\text{max}}$  is to be considered. Where acceleration components in three directions need to be considered, an ellipsoid is to be used instead of the ellipse in **Fig 6.1**. The above formula applies only to full tanks.

- (B) External pressure  
External design pressure loads is to be based on the difference between the minimum internal pressure and the maximum external pressure to which any portion of the tank may be simultaneously subjected.
- (C) Thermally induced loads **[See Guidance]**
  - (a) Transient thermally induced loads during cooling down periods are to be considered for tanks intended for liquefied gas fuel temperatures below minus 55 °C.
  - (b) Stationary thermally induced loads are to be considered for liquefied gas fuel containment systems where the design supporting arrangements or attachments and operating temperature may give rise to significant thermal stresses (see **902**).
- (D) Vibration **[See Guidance]**  
The potentially damaging effects of vibration on the liquefied gas fuel containment system are to be considered.
- (E) Interaction loads  
The static component of loads resulting from interaction between liquefied gas fuel containment system and the hull structure, as well as loads from associated structure and equipment, is to be considered.
- (F) Loads associated with construction and installation  
Loads or conditions associated with construction and installation are to be considered, e.g. lifting.
- (G) Test loads  
Account is to be taken of the loads corresponding to the testing of the liquefied gas fuel containment system referred to in **Ch 16, Sec 5**.
- (H) Static heel loads **[See Guidance]**  
Loads corresponding to the most unfavourable static heel angle within the range 0° to 30° are to be considered.
- (I) Other loads  
Any other loads not specifically addressed, which could have an effect on the liquefied gas fuel containment system, are to be taken into account.

#### 4. Environmental loads

- (1) Environmental loads are defined as those loads on the liquefied gas fuel containment system that are caused by the surrounding environment and that are not otherwise classified as a permanent, functional or accidental load.
  - (A) Loads due to ship motion **[See Guidance]**  
The determination of dynamic loads is to take into account the long-term distribution of ship motion in irregular seas, which the ship will experience during its operating life. Account may be taken of the reduction in dynamic loads due to necessary speed reduction and variation of heading. The ship's motion is to include surge, sway, heave, roll, pitch and yaw. The accelerations acting on tanks are to be estimated at their centre of gravity and include the following components:
    - (a) vertical acceleration: motion accelerations of heave, pitch and, possibly roll (normal to the ship base);
    - (b) transverse acceleration: motion accelerations of sway, yaw and roll and gravity component of roll; and
    - (c) longitudinal acceleration: motion accelerations of surge and pitch and gravity component of pitch.
 Methods to predict accelerations due to ship motion are to be proposed and approved by the Society. Ships for restricted service may be given special consideration.
  - (B) Dynamic interaction loads  
Account is to be taken of the dynamic component of loads resulting from interaction between liquefied gas fuel containment systems and the hull structure, including loads from associated structures and equipment.

- (C) Sloshing loads **[See Guidance]**  
The sloshing loads on a liquefied gas fuel containment system and internal components are to be evaluated for the full range of intended filling levels.
- (D) Snow and ice loads  
Snow and icing are to be considered, if relevant.
- (E) Loads due to navigation in ice  
Loads due to navigation in ice are to be considered for ships intended for such service.
- (F) Green sea loading  
Account is to be taken to loads due to water on deck.
- (G) Wind loads  
Account is to be taken to wind generated loads as relevant.

### 5. Accidental loads

Accidental loads are defined as loads that are imposed on a liquefied gas fuel containment system and its supporting arrangements under abnormal and unplanned conditions.

#### (1) Collision load

The collision load is to be determined based on the fuel containment system under fully loaded condition with an inertial force corresponding to " $a$ " in the table below in forward direction and " $a/2$ " in the aft direction, where " $g$ " is gravitational acceleration.

**Table 6.2 Design acceleration in relation with ship length**

Ship Length ( $L$ ) (m)	Design acceleration ( $a$ ) ( $m/s^2$ )
$L > 100m$	$0.5g$
$60 < L \leq 100m$	$(2 - \frac{3(L-60)}{80})g$
$L \leq 60m$	$2g$
Special consideration is to be given to ships with Froude Number ( $Fn = \frac{V}{\sqrt{gL}}$ , $g = 9.81m/s^2$ ) $> 0.4$	

#### (2) Loads due to flooding on ship

For independent tanks, loads caused by the buoyancy of a fully submerged empty tank are to be considered in the design of anti-flotation chocks and the supporting structure in both the adjacent hull and tank structure.

### 410. Structural integrity

- The structural design is to ensure that tanks have an adequate capacity to sustain all relevant loads with an adequate margin of safety. This is to take into account the possibility of plastic deformation, buckling, fatigue and loss of liquid and gas tightness.
- The structural integrity of liquefied gas fuel containment systems can be demonstrated by compliance with **415.**, as appropriate for the liquefied gas fuel containment system type.
- For other liquefied gas fuel containment system types, that are of novel design or differ significantly from those covered by **415.**, the structural integrity is to be demonstrated by compliance with **416.**.

### 411. Structural analysis

#### 1. Analysis

- The design analyses is to be based on accepted principles of statics, dynamics and strength of materials.
- Simplified methods or simplified analyses may be used to calculate the load effects, provided that they are conservative. Model tests may be used in combination with, or instead of, theoretical calculations. In cases where theoretical methods are inadequate, model or full-scale tests may be required.

- (3) When determining responses to dynamic loads, the dynamic effect is to be taken into account where it may affect structural integrity.

## 2. Load scenarios

- (1) For each location or part of the liquefied gas fuel containment system to be considered and for each possible mode of failure to be analysed, all relevant combinations of loads that may act simultaneously are to be considered.
- (2) The most unfavourable scenarios for all relevant phases during construction, handling, testing and in service conditions are to be considered.
- (3) When the static and dynamic stresses are calculated separately and unless other methods of calculation are justified, the total stresses are to be calculated according to:

$$\sigma_x = \sigma_{x,st} \pm \sqrt{\sum(\sigma_{x,dyn})^2}$$

$$\sigma_y = \sigma_{y,st} \pm \sqrt{\sum(\sigma_{y,dyn})^2}$$

$$\sigma_z = \sigma_{z,st} \pm \sqrt{\sum(\sigma_{z,dyn})^2}$$

$$\tau_{xy} = \tau_{xy,st} \pm \sqrt{\sum(\tau_{xy,dyn})^2}$$

$$\tau_{xz} = \tau_{xz,st} \pm \sqrt{\sum(\tau_{xz,dyn})^2}$$

$$\tau_{yz} = \tau_{yz,st} \pm \sqrt{\sum(\tau_{yz,dyn})^2}$$

$\sigma_{x,st}$ ,  $\sigma_{y,st}$ ,  $\sigma_{z,st}$ ,  $\tau_{xy,st}$ ,  $\tau_{xz,st}$ , and  $\tau_{yz,st}$  are static stresses; and

$\sigma_{x,dyn}$ ,  $\sigma_{y,dyn}$ ,  $\sigma_{z,dyn}$ ,  $\tau_{xy,dyn}$ ,  $\tau_{xz,dyn}$ , and  $\tau_{yz,dyn}$  are dynamic stresses,

each is to be determined separately from acceleration components and hull strain components due to deflection and torsion.

## 412. Design conditions

All relevant failure modes are to be considered in the design for all relevant load scenarios and design conditions. The design conditions are given in the earlier part of this chapter, and the load scenarios are covered by **411. 2**.

### 1. Ultimate design condition

- (1) Structural capacity may be determined by testing, or by analysis, taking into account both the elastic and plastic material properties, by simplified linear elastic analysis or by the provisions of this Rules:

(A) Plastic deformation and buckling are to be considered.

(B) Analysis is to be based on characteristic load values as follows:

Permanent loads : Expected values

Functional loads : Specified values

Environmental loads For wave loads : most probable largest load encountered during  $10^8$  wave encounters.

(C) For the purpose of ultimate strength assessment the following material parameters apply:

**[See Guidance]**

$R_e$  = specified minimum yield stress at room temperature (N/mm<sup>2</sup>). If the stress-strain curve does not show a defined yield stress, the 0.2 % proof stress applies.

$R_m$  = specified minimum tensile strength at room temperature (N/mm<sup>2</sup>). For welded connections where under-matched welds, i.e. where the weld metal has lower tensile strength than the parent metal, are unavoidable, such as in some aluminium alloys, the respective  $R_e$  and  $R_m$  of the welds, after any applied heat treatment, are to be used. In such cases the transverse weld tensile strength is not to be less than the actual yield strength of the parent metal. If this cannot be achieved, welded structures made from such materials are not to be incorporated in liquefied gas fuel containment systems.

The above properties are to correspond to the minimum specified mechanical properties of the material, including the weld metal in the as fabricated condition. Subject to special consideration by the Society, account may be taken of the enhanced yield stress and tensile strength at low temperature.

(D) The equivalent stress  $\sigma_c$  (von Mises, Huber) is to be determined by:

$$\sigma_c = \sqrt{\sigma_x^2 + \sigma_y^2 + \sigma_z^2 - \sigma_x\sigma_y - \sigma_x\sigma_z - \sigma_y\sigma_z + 3(\tau_{xy}^2 + \tau_{xz}^2 + \tau_{yz}^2)}$$

$\sigma_x, \sigma_y, \sigma_z$ : total normal stress in  $x, y, z$ -direction

$\tau_{xy}, \tau_{xz}, \tau_{yz}$ : total shear stress in  $x-y, x-z, y-z$  plane;

The above values are to be calculated as described in **411. 2 (3)**.

(E) Allowable stresses for materials other than those covered by **Ch 7, 401**. are to be subject to approval by the Society in each case.

(F) Stresses may be further limited by fatigue analysis, crack propagation analysis and buckling criteria.

## 2. Fatigue Design Condition [See Guidance]

- (1) The fatigue design condition is the design condition with respect to accumulated cyclic loading.
- (2) Where a fatigue analysis is required the cumulative effect of the fatigue load is to comply with:

$$\sum \frac{n_i}{N_i} + \frac{n_{Loading}}{N_{Loading}} \leq C_W$$

where:

$n_i$  = number of stress cycles at each stress level during the life of the tank;

$N_i$  = number of cycles to fracture for the respective stress level according to the Wohler (S-N) curve;

$n_{Loading}$  = number of loading and unloading cycles during the life of the tank not to be less than 1000. Loading and unloading cycles include a complete pressure and thermal cycle;

$N_{Loading}$  = number of cycles to fracture for the fatigue loads due to loading and unloading;  
and

$C_W$  = maximum allowable cumulative fatigue damage ratio. The fatigue damage is to be based on the design life of the tank but not less than  $10^8$  wave encounters.

- (3) Where required, the liquefied gas fuel containment system is to be subject to fatigue analysis, considering all fatigue loads and their appropriate combinations for the expected life of the liquefied gas fuel containment system. Consideration is to be given to various filling conditions.
- (4) Design S-N curves used in the analysis is to be applicable to the materials and weldments, construction details, fabrication procedures and applicable state of the stress envisioned. The S-N curves is to be based on a 97.6% probability of survival corresponding to the mean-minus-two-standard-deviation curves of relevant experimental data up to final failure. Use of S-N curves derived in a different way requires adjustments to the acceptable  $C_W$  values specified in (7) to (9).
- (5) Analysis is to be based on characteristic load values as follows:

(A) Permanent loads Expected values

(B) Functional loads Specified values or specified history

(C) Environmental loads Expected load history, but not less than  $10^8$  cycles

If simplified dynamic loading spectra are used for the estimation of the fatigue life, those are to be specially considered by the Society.

- (6) Where the size of the secondary barrier is reduced, as is provided for in **402. 3**, fracture mechanics analyses of fatigue crack growth are to be carried out to determine: **[See Guidance]**
- (A) crack propagation paths in the structure, where necessitated by (7) to (9), as applicable;
  - (B) crack growth rate;
  - (C) the time required for a crack to propagate to cause a leakage from the tank;
  - (D) the size and shape of through thickness cracks; and
  - (E) the time required for detectable cracks to reach a critical state after penetration through the thickness.

The fracture mechanics are in general based on crack growth data taken as a mean value plus two standard deviations of the test data. Methods for fatigue crack growth analysis and fracture mechanics are to be based on recognized standards.

In analysing crack propagation the largest initial crack not detectable by the inspection method applied is to be assumed, taking into account the allowable non-destructive testing and visual inspection criterion as applicable.

Crack propagation analysis specified in (7) the simplified load distribution and sequence over a period of 15 days may be used. Such distributions may be obtained as indicated in **Fig 6.3**. Load distribution and sequence for longer periods, such as in (8) and (9) are to be approved by the Society. The arrangements is to comply with (7) to (9) as applicable.

- (7) For failures that can be reliably detected by means of leakage detection:  $C_W$  is to be less than or equal to 0.5. **[See Guidance]**

Predicted remaining failure development time, from the point of detection of leakage till reaching a critical state, is not to be less than 15 days unless different regulations apply for ships engaged in particular voyages.

- (8) For failures that cannot be detected by leakage but that can be reliably detected at the time of in-service inspections:  $C_W$  is to be less than or equal to 0.5.

Predicted remaining failure development time, from the largest crack not detectable by in-service inspection methods until reaching a critical state, is not to be less than three (3) times the inspection interval.

- (9) In particular locations of the tank where effective defect or crack development detection cannot be assured, the following, more stringent, fatigue acceptance criteria is to be applied as a minimum:  $C_W$  is to be less than or equal to 0.1.

Predicted failure development time, from the assumed initial defect until reaching a critical state, is not to be less than three (3) times the lifetime of the tank.

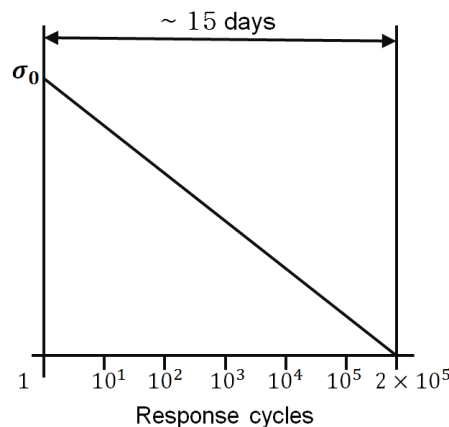

$\sigma_0$  : most probable maximum stress over the life of ship  
 Response cycle scale is logarithmic; the value of  $2 \times 10^5$  is given as an example of estimate.

**Fig 6.3 Simplified Load Distribution**

### 3. Accidental design condition

- (1) The accidental design condition is a design condition for accidental loads with extremely low probability of occurrence.
- (2) Analysis is to be based on the characteristic values as follows:
  - (A) Permanent loads : Expected values
  - (B) Functional loads : Specified values
  - (C) Environmental loads : Specified values
  - (D) Accidental loads : Specified values or expected values

Loads mentioned in **409. 3** (3) (H) and **409. 5** need not be combined with each other or with wave-induced loads.

## 413. Materials

### 1. Materials forming ship structure

- (1) To determine the grade of plate and sections used in the hull structure, a temperature calculation is to be performed for all tank types. The following assumptions are to be made in this calculation: **[See Guidance]**
  - (A) The primary barrier of all tanks is to be assumed to be at the liquefied gas fuel temperature.
  - (B) In addition to (A) above, where a complete or partial secondary barrier is required it is to be assumed to be at the liquefied gas fuel temperature at atmospheric pressure for any one tank only.
  - (C) For worldwide service, ambient temperatures are to be taken as 5 °C for air and 0 °C for seawater. Higher values may be accepted for ships operating in restricted areas and conversely, lower values may be imposed by the Society for ships trading to areas where lower temperatures are expected during the winter months.
  - (D) Still air and sea water conditions are to be assumed, i.e. no adjustment for forced convection.
  - (E) Degradation of the thermal insulation properties over the life of the ship due to factors such as thermal and mechanical ageing, compaction, ship motions and tank vibrations as defined in **3** (6) and **3** (7) are to be assumed.
  - (F) The cooling effect of the rising boil-off vapour from the leaked liquefied gas fuel is to be taken into account where applicable.
  - (G) Credit for hull heating may be taken in accordance with (3), provided the heating arrangements are in compliance with (4).
  - (H) No credit is to be given for any means of heating, except as described in (3).
  - (I) For members connecting inner and outer hulls, the mean temperature may be taken for determining the steel grade.
- (2) The materials of all hull structures for which the calculated temperature in the design condition is below 0 °C, due to the influence of liquefied gas fuel temperature, is to be in accordance with **Table 7.5**. This includes hull structure supporting the liquefied gas fuel tanks, inner bottom plating, longitudinal bulkhead plating, transverse bulkhead plating, floors, webs, stringers and all attached stiffening members.
- (3) Means of heating structural materials may be used to ensure that the material temperature does not fall below the minimum allowed for the grade of material specified in **Table 7.5**. In the calculations required in (1), credit for such heating may be taken in accordance with the following principles:
  - (A) for any transverse hull structure;
  - (B) for longitudinal hull structure referred to in (2) where colder ambient temperatures are specified, provided the material remains suitable for the ambient temperature conditions of plus 5 °C for air and 0 °C for seawater with no credit taken in the calculations for heating; and
  - (C) as an alternative to (B) for longitudinal bulkhead between liquefied gas fuel tanks, credit may be taken for heating provided the material remain suitable for a minimum design temperature of minus 30 °C, or a temperature 30 °C lower than that determined by (1) with the heating considered, whichever is less. In this case, the ship's longitudinal strength is to comply with **Pt 3, Ch 3 of Rules for the classification of steel ships** for both when those bulkhead(s) are considered effective and not.
- (4) The means of heating referred to in (3) are to comply with the following:

- (A) the heating system is to be arranged so that, in the event of failure in any part of the system, standby heating can be maintained equal to no less than 100 % of the theoretical heat requirement;
- (B) the heating system is to be considered as an essential auxiliary. All electrical components of at least one of the systems provided in accordance with (3) (A) are to be supplied from the emergency source of electrical power; and
- (C) the design and construction of the heating system are to be included in the approval of the containment system by the Society.

## 2. Materials of primary and secondary barriers

- (1) Metallic materials used in the construction of primary and secondary barriers not forming the hull, are to be suitable for the design loads that they may be subjected to, and be in accordance with **Table 7.1, 7.2 or 7.3**.
- (2) Materials, either non-metallic or metallic but not covered by **Table 7.1, 7.2 and 7.3**, used in the primary and secondary barriers may be approved by the Society considering the design loads that they may be subjected to, their properties and their intended use.
- (3) Where non-metallic materials (refer to **416.**), including composites, are used for or incorporated in the primary or secondary barriers, they are to be tested for the following properties, as applicable, to ensure that they are adequate for the intended service:
  - (A) compatibility with the liquefied gas fuels;
  - (B) ageing;
  - (C) mechanical properties;
  - (D) thermal expansion and contraction;
  - (E) abrasion;
  - (F) cohesion;
  - (G) resistance to vibrations;
  - (H) resistance to fire and flame spread; and
  - (I) resistance to fatigue failure and crack propagation.
- (4) The above properties, where applicable, are to be tested for the range between the expected maximum temperature in service and 5 °C below the minimum design temperature, but not lower than minus 196 °C.
- (5) Where non-metallic materials, including composites, are used for the primary and secondary barriers, the joining processes are to also be tested as described above.
- (6) Consideration may be given to the use of materials in the primary and secondary barrier, which are not resistant to fire and flame spread, provided they are protected by a suitable system such as a permanent inert gas environment, or are provided with a fire retardant barrier.

## 3. Thermal insulation and other materials used in liquefied gas fuel containment systems

- (1) Load-bearing thermal insulation and other materials used in liquefied gas fuel containment systems are to be suitable for the design loads. **[See Guidance]**
- (2) Thermal insulation and other materials used in liquefied gas fuel containment systems are to have the following properties, as applicable, to ensure that they are adequate for the intended service: **[See Guidance]**
  - (A) compatibility with the liquefied gas fuels;
  - (B) solubility in the liquefied gas fuel;
  - (C) absorption of the liquefied gas fuel;
  - (D) shrinkage;
  - (E) ageing;
  - (F) closed cell content;
  - (G) density;
  - (H) mechanical properties, to the extent that they are subjected to liquefied gas fuel and other loading effects, thermal expansion and contraction;
  - (I) abrasion;
  - (J) cohesion;
  - (K) thermal conductivity;
  - (L) resistance to vibrations;
  - (M) resistance to fire and flame spread; and
  - (N) resistance to fatigue failure and crack propagation.
- (3) The above properties, where applicable, are to be tested for the range between the expected maximum temperature in service and 5 °C below the minimum design temperature, but not low-

- er than minus 196 °C.
- (4) Due to location or environmental conditions, thermal insulation materials are to have suitable properties of resistance to fire and flame spread and are to be adequately protected against penetration of water vapour and mechanical damage. Where the thermal insulation is located on or above the exposed deck, and in way of tank cover penetrations, it is to have suitable fire resistance properties in accordance with a recognized standard or be covered with a material having low flame spread characteristics and forming an efficient approved vapour seal.  
**[See Guidance]**
  - (5) Thermal insulation that does not meet recognized standards for fire resistance may be used in fuel storage hold spaces that are not kept permanently inerted, provided its surfaces are covered with material with low flame spread characteristics and that forms an efficient approved vapour seal.
  - (6) Testing for thermal conductivity of thermal insulation is to be carried out on suitably aged samples.
  - (7) Where powder or granulated thermal insulation is used, measures are to be taken to reduce compaction in service and to maintain the required thermal conductivity and also prevent any undue increase of pressure on the liquefied gas fuel containment system.

#### 414. Construction processes

##### 1. Weld joint design

- (1) All welded joints of the shells of independent tanks are to be of the in-plane butt weld full penetration type. For dome-to-shell connections only, tee welds of the full penetration type may be used depending on the results of the tests carried out at the approval of the welding procedure. Except for small penetrations on domes, nozzle welds are also to be designed with full penetration. **[See Guidance]**
- (2) Welding joint details for type C independent tanks, and for the liquid-tight primary barriers of type B independent tanks primarily constructed of curved surfaces, is to be as follows:
  - (A) All longitudinal and circumferential joints are to be of butt welded, full penetration, double vee or single vee type. Full penetration butt welds are to be obtained by double welding or by the use of backing rings. If used, backing rings are to be removed except from very small process pressure vessels. (For vacuum insulated tanks without manhole, the longitudinal and circumferential joints are to meet the aforementioned requirements, except for the erection weld joint of the outer shell, which may be a onside welding with backing rings.) Other edge preparations may be permitted, depending on the results of the tests carried out at the approval of the welding procedure. For connections of tank shell to a longitudinal bulkhead of type C bilobe tanks, tee welds of the full penetration type may be accepted.  
**[See Guidance]**
  - (B) The bevel preparation of the joints between the tank body and domes and between domes and relevant fittings is to be designed according to **Pt 5, Ch 5 of Rules for the classification of steel ships**. All welds connecting nozzles, domes or other penetrations of the vessel and all welds connecting flanges to the vessel or nozzles are to be full penetration welds.

##### 2. Design for gluing and other joining processes

- (1) The design of the joint to be glued (or joined by some other process except welding) is to take account of the strength characteristics of the joining process.

#### 415. Tank types

##### 1. Type A independent tanks **[See Guidance]**

- (1) Design basis
  - (A) Type A independent tanks are tanks primarily designed using classical ship-structural analysis procedures in accordance with the requirements of the Society. Where such tanks are primarily constructed of plane surfaces, the design vapour pressure  $P_0$  is to be less than 0.07 MPa.
  - (B) A complete secondary barrier is required as defined in **403**.. The secondary barrier is to be designed in accordance with **404**..
- (2) Structural analysis
  - (A) A structural analysis is to be performed taking into account the internal pressure as indicated in **409. 3 (3) (A)**, and the interaction loads with the supporting and keying system

as well as a reasonable part of the ship's hull.

- (B) For parts, such as structure in way of supports, not otherwise covered by the requirements in this Rules, stresses are to be determined by direct calculations, taking into account the loads referred to in **409. 2** to **409. 5** as far as applicable, and the ship deflection in way of supports.
  - (C) The tanks with supports are to be designed for the accidental loads specified in **409. 5**. These loads need not be combined with each other or with environmental loads.
- (3) Ultimate design condition
- (A) For tanks primarily constructed of plane surfaces, the nominal membrane stresses for primary and secondary members (stiffeners, web frames, stringers, girders), when calculated by classical analysis procedures, are not to exceed the lower of  $R_m/2.66$  or  $R_e/1.33$  for nickel steels, carbon-manganese steels, austenitic steels and aluminium alloys, where  $R_m$  and  $R_e$  are defined in **412. 1** (1) (C). However, if detailed calculations are carried out for the primary members, the equivalent stress  $\sigma_c$ , as defined in **412. 1** (1) (D), may be increased over that indicated above to a stress acceptable to the Society. Calculations are to take into account the effects of bending, shear, axial and torsional deformation as well as the hull/liquefied gas fuel tank interaction forces due to the deflection of the hull structure and liquefied gas fuel tank bottoms.
  - (B) Tank boundary scantlings are to meet at least **Pt 3, Ch 15 of Rules for the classification of steel ships**. for deep tanks taking into account the internal pressure as indicated in **409. 3** (3) (A) and any corrosion allowance required by **401. 7**.
  - (C) The liquefied gas fuel tank structure is to be reviewed against potential buckling.
- (4) Accidental design condition
- (A) The tanks and the tank supports are to be designed for the accidental loads and design conditions specified in **401. 6** and **409. 5** as relevant.
  - (B) When subjected to the accidental loads specified in **409. 5**, the stress is to comply with the acceptance criteria specified in **1. (3)**, modified as appropriate taking into account their lower probability of occurrence.

## 2. Type B independent tanks

- (1) Design basis
- (A) Type B independent tanks are tanks designed using model tests, refined analytical tools and analysis methods to determine stress levels, fatigue life and crack propagation characteristics. Where such tanks are primarily constructed of plane surfaces (prismatic tanks) the design vapour pressure  $P_0$  is to be less than  $0.07 P_0$ .
  - (B) A partial secondary barrier with a protection system is required as defined in **403.**. The small leak protection system is to be designed according to **405.**.
- (2) Structural analysis **[See Guidance]**
- (A) The effects of all dynamic and static loads are to be used to determine the suitability of the structure with respect to:
    - (a) plastic deformation;
    - (b) buckling;
    - (c) fatigue failure; and
    - (d) crack propagation.
 Finite element analysis or similar methods and fracture mechanics analysis or an equivalent approach, is to be carried out.
  - (B) A three-dimensional analysis are to be carried out to evaluate the stress levels, including interaction with the ship's hull. The model for this analysis is to include the liquefied gas fuel tank with its supporting and keying system, as well as a reasonable part of the hull.
  - (C) A complete analysis of the particular ship accelerations and motions in irregular waves, and of the response of the ship and its liquefied gas fuel tanks to these forces and motions, is to be performed unless the data is available from similar ships.
- (3) Ultimate design condition
- (A) Plastic deformation  
For type B independent tanks, primarily constructed of bodies of revolution, the allowable stresses are not to exceed:  
The thickness of the skin plate and the size of the stiffener is not to be less than those required for type A independent tanks.

$$\sigma_m \leq f$$

$$\begin{aligned}\sigma_L &\leq 1.5f \\ \sigma_b &\leq 1.5F \\ \sigma_L + \sigma_b &\leq 1.5F \\ \sigma_m + \sigma_b &\leq 1.5F \\ \sigma_m + \sigma_b + \sigma_g &\leq 3.0F \\ \sigma_L + \sigma_b + \sigma_g &\leq 3.0F\end{aligned}$$

$\sigma_m$  : equivalent primary general membrane stress

$\sigma_L$  : equivalent primary local membrane stress

$\sigma_b$  : equivalent primary bending stress

$\sigma_g$  : equivalent secondary stress

$f$  : the lesser of  $(R_m/A)$  or  $(R_e/B)$ ; and

$F$  : the lesser of  $(R_m/C)$  or  $(R_e/D)$ ,

$R_m$  and  $R_e$  = as defined in **412. 1** (1) (C).

$\sigma_m$ ,  $\sigma_L$ ,  $\sigma_g$  and  $\sigma_b$  = as defined in (7).

The values  $A$ ,  $B$ ,  $C$  and  $D$  are to have at least the following minimum values:

**Table 6.3 The values A, B, C and D**

	Nickel steels and carbon manganese steels	Austenitic steel	Aluminium alloys
$A$	3	3.5	4
$B$	2	1.6	1.5
$C$	3	3	3
$D$	1.5	1.5	1.5

The above figures may be altered considering the design condition considered in acceptance with the Society. For type B independent tanks, primarily constructed of plane surfaces, the allowable membrane equivalent stresses applied for finite element analysis are not to exceed:

(A) for nickel steels and carbon-manganese steels, the lesser of  $R_m/2$  or  $R_e/1.2$ ;  
 (B) for austenitic steels, the lesser of  $R_m/2.5$  or  $R_e/1.2$ ; and  
 (C) for aluminium alloys, the lesser of  $R_m/2.5$  or  $R_e/1.2$ .

The above figures may be amended considering the locality of the stress, stress analysis methods and design condition considered in acceptance with the Society.

#### (B) Buckling

Buckling strength analyses of liquefied gas fuel tanks subject to external pressure and other loads causing compressive stresses are to be carried out in accordance with recognized standards. The method is to adequately account for the difference in theoretical and actual buckling stress as a result of plate edge misalignment, lack of straightness or flatness, ovality and deviation from true circular form over a specified arc or chord length, as applicable.

#### (4) Fatigue design condition

(A) Fatigue and crack propagation assessment are to be performed in accordance with the provisions of **412. 2**. The acceptance criteria is to comply with **412. 2** (7), (8) or (9), depending on the detectability of the defect.

(B) Fatigue analysis is to consider construction tolerances.

(C) Where deemed necessary by the Society, model tests may be required to determine stress concentration factors and fatigue life of structural elements.

#### (5) Accidental design condition

(A) The tanks and the tank supports are to be designed for the accidental loads and design conditions specified in **401. 6** (3) and **409. 5**, as relevant.

(B) When subjected to the accidental loads specified in **409. 5**, the stress is to comply with the

acceptance criteria specified in (3), modified as appropriate, taking into account their lower probability of occurrence.

(6) Marking

Any marking of the pressure vessel is to be achieved by a method that does not cause unacceptable local stress raisers.

(7) Stress categories

For the purpose of stress evaluation, stress categories are defined in this section as follows:

- (A) Normal stress is the component of stress normal to the plane of reference.
- (B) Membrane stress is the component of normal stress that is uniformly distributed and equal to the average value of the stress across the thickness of the section under consideration.
- (C) Bending stress is the variable stress across the thickness of the section under consideration, after the subtraction of the membrane stress.
- (D) Shear stress is the component of the stress acting in the plane of reference.
- (E) Primary stress is a stress produced by the imposed loading, which is necessary to balance the external forces and moments. The basic characteristic of a primary stress is that it is not self-limiting. Primary stresses that considerably exceed the yield strength will result in failure or at least in gross deformations.
- (F) Primary general membrane stress is a primary membrane stress that is so distributed in the structure that no redistribution of load occurs as a result of yielding.
- (G) Primary local membrane stress arises where a membrane stress produced by pressure or other mechanical loading and associated with a primary or a discontinuity effect produces excessive distortion in the transfer of loads for other portions of the structure. Such a stress is classified as a primary local membrane stress, although it has some characteristics of a secondary stress. A stress region may be considered as local, if:

$$S_1 \leq 0.5 \sqrt{Rt} \quad \text{and} \quad S_2 \geq 2.5 \sqrt{Rt}$$

where:

$S_1$  = distance in the meridional direction over which the equivalent stress exceeds  $1.1f$

$S_2$  = distance in the meridional direction to another region where the limits for primary general membrane stress are exceeded;

$R$  = mean radius of the vessel;

$t$  = wall thickness of the vessel at the location where the primary general membrane stress limit is exceeded; and

- (H) Secondary stress is a normal stress or shear stress developed by constraints of adjacent parts or by self-constraint of a structure. The basic characteristic of a secondary stress is that it is self-limiting. Local yielding and minor distortions can satisfy the conditions that cause the stress to occur.

### 3. Type C independent tanks [See Guidance]

(1) Design basis

- (A) The design basis for type C independent tanks is based on pressure vessel criteria modified to include fracture mechanics and crack propagation criteria. The minimum design pressure defined in (B) is intended to ensure that the dynamic stress is sufficiently low so that an initial surface flaw will not propagate more than half the thickness of the shell during the lifetime of the tank.

- (B) The design vapour pressure is not to be less than:

$$P_0 = 0.2 + AC(\rho_r)^{1.5} \quad (\text{MPa})$$

where:

$$A = 0.00185 \left( \frac{\sigma_m}{\Delta\sigma_A} \right)^2$$

with:

$\sigma_m$  : design primary membrane stress;

$\Delta\sigma_A$  = allowable dynamic membrane stress (double amplitude at probability level  $Q=10^{-8}$ ) and equal to:

- 55 N/mm<sup>2</sup> for ferritic-perlitic, martensitic and austenitic steel;
- 25 N/mm<sup>2</sup> for aluminium alloy (5083-O);

$C$  = a characteristic tank dimension to be taken as the greatest of the following:

$h$ ,  $0.75b$  or  $0.45l$ ,

with:

$h$  = height of tank (dimension in ship's vertical direction) (m);

$b$  = width of tank (dimension in ship's transverse direction) (m);

$l$  = length of tank (dimension in ship's longitudinal direction) (m);

$\rho_r$  = the relative density of the fuel ( $\rho_r = 1$  for fresh water) at the design temperature.

(2) Shell thickness

(A) In considering the shell thickness the following apply:

- (a) for pressure vessels, the thickness calculated according to (D) is to be considered as a minimum thickness after forming, without any negative tolerance;
- (b) for pressure vessels, the minimum thickness of shell and heads including corrosion allowance, after forming, is not to be less than 5 mm for carbon manganese steels and nickel steels, 3 mm for austenitic steels or 7 mm for aluminium alloys; and
- (c) the welded joint efficiency factor to be used in the calculation according to (D) is to be 0.95 when the inspection and the non-destructive testing referred to in **Ch 16, 306. 4** are carried out. This figure may be increased up to 1.0 when account is taken of other considerations, such as the material used, type of joints, welding procedure and type of loading. For process pressure vessels the Society may accept partial non-destructive examinations, but not less than those of **Ch 16, 306. 4**, depending on such factors as the material used, the design temperature, the nil ductility transition temperature of the material as fabricated and the type of joint and welding procedure, but in this case an efficiency factor of not more than 0.85 is to be adopted. For special materials the above-mentioned factors are to be reduced, depending on the specified mechanical properties of the welded joint.

(B) The design liquid pressure defined in **409. 3 (3) (A)** is to be taken into account in the internal pressure calculations.

(C) The design external pressure  $P_e$ , used for verifying the buckling of the pressure vessels, is not to be less than that given by:

$$P_e = P_1 + P_2 + P_3 + P_4 \quad (\text{MPa})$$

where:

$P_1$  = setting value of vacuum relief valves. For vessels not fitted with vacuum relief valves  $P_1$  is to be specially considered, but is not in general to be taken as less than 0.025 MPa.

$P_2$  = the set pressure of the pressure relief valves (PRVs) for completely closed spaces containing pressure vessels or parts of pressure vessels; elsewhere  $P_2 = 0$ .

$P_3$  = compressive actions in or on the shell due to the weight and contraction of thermal insulation, weight of shell including corrosion allowance and other miscellaneous external pressure loads to which the pressure vessel may be subjected. These include, but are not limited to, weight of domes, weight of towers and piping, effect of product in the partially filled condition, accelerations and hull deflection. In addition, the local effect of external or internal pressures or both is to be taken into account.

$P_4$  = external pressure due to head of water for pressure vessels or part of pressure vessels

on exposed decks; elsewhere  $P_4 = 0$ .

(D) Scantlings based on internal pressure are to be calculated as follows:

The thickness and form of pressure-containing parts of pressure vessels, under internal pressure, as defined in **409. 3. (3) (A)**, including flanges, are to be determined. These calculations are in all cases to be based on accepted pressure vessel design theory. Openings in pressure-containing parts of pressure vessels are to be reinforced in accordance with **Rules for the Classification of Steel Ships**.

(E) Stress analysis in respect of static and dynamic loads is to be performed as follows:

- (a) pressure vessel scantlings are to be determined in accordance with (A) to (D) and (3);
- (b) calculations of the loads and stresses in way of the supports and the shell attachment of the support are to be made. Loads referred to in **409. 2 to 5** are to be used, as applicable. Stresses in way of the supports are to be to a recognized standard acceptable to the Society. In special cases a fatigue analysis may be required by the Society; and
- (c) if required by the Society, secondary stresses and thermal stresses are to be specially considered.

(3) Ultimate design condition

(A) Plastic deformation

For type C independent tanks, the allowable stresses are not to exceed:

$$\sigma_m \leq f$$

$$\sigma_L \leq 1.5f$$

$$\sigma_b \leq 1.5f$$

$$\sigma_L + \sigma_b \leq 1.5f$$

$$\sigma_m + \sigma_b \leq 1.5f$$

$$\sigma_m + \sigma_b + \sigma_g \leq 3.0f$$

$$\sigma_L + \sigma_b + \sigma_g \leq 3.0f$$

where:

$\sigma_m$  = equivalent primary general membrane stress;

$\sigma_L$  = equivalent primary local membrane stress;

$\sigma_b$  = equivalent primary bending stress;

$\sigma_g$  = equivalent secondary stress; and

$f$  = the lesser of  $R_m/A$  or  $R_c/B$ ,

$R_m$  and  $R_c$  = as defined in **412. 1 (1) (C)**.

$\sigma_m$ ,  $\sigma_L$ ,  $\sigma_g$  and  $\sigma_b$  = as defined in **2 (7)**.

The values  $A$  and  $B$  are to have at least the following minimum values:

**Table 6.4 Values of  $A$  and  $B$**

	Nickel steels and carbon-manganese steels	Austenitic steels	Aluminium alloys
$A$	3	3.5	4
$B$	1.5	1.5	1.5

(B) Buckling criteria is to be as follows:

The thickness and form of pressure vessels subject to external pressure and other loads causing compressive stresses are to be based on calculations using accepted pressure vessel buckling theory and are to adequately account for the difference in theoretical and actual buckling stress as a result of plate edge misalignment, ovality and deviation from true circular form over a specified arc or chord length.

- (4) Fatigue design condition
- (A) For type C independent tanks where the liquefied gas fuel at atmospheric pressure is below minus 55 °C, the Society may require additional verification to check their compliance with (1), regarding static and dynamic stress depending on the tank size, the configuration of the tank and arrangement of its supports and attachments.
  - (B) For vacuum insulated tanks, special attention is to be made to the fatigue strength of the support design and special considerations is to also be made to the limited inspection possibilities between the inside and outer shell.
- (5) Accidental design condition
- (A) The tanks and the tank supports are to be designed for the accidental loads and design conditions specified in **209. 5** and **401. 6** (3), as relevant.
  - (B) When subjected to the accidental loads specified in **409. 5**, the stress is to comply with the acceptance criteria specified in (3) (A), modified as appropriate taking into account their lower probability of occurrence.
- (6) Marking
- The required marking of the pressure vessel is to be achieved by a method that does not cause unacceptable local stress raisers.

#### 4. Membrane tanks [See Guidance]

- (1) Design basis
- (A) The design basis for membrane containment systems is that thermal and other expansion or contraction is compensated for without undue risk of losing the tightness of the membrane.
  - (B) A systematic approach, based on analysis and testing, is to be used to demonstrate that the system will provide its intended function in consideration of the identified in service events as specified in (2) (A).
  - (C) A complete secondary barrier is required as defined in **403.**. The secondary barrier is to be designed according to **404.**.
  - (D) The design vapour pressure  $P_0$  is not to normally exceed 0.025 MPa. If the hull scantlings are increased accordingly and consideration is given, where appropriate, to the strength of the supporting thermal insulation,  $P_0$  may be increased to a higher value but less than 0.070 MPa.
  - (E) The definition of membrane tanks does not exclude designs such as those in which non-metallic membranes are used or where membranes are included or incorporated into the thermal insulation.
  - (F) The thickness of the membranes is normally not to exceed 10 mm.
  - (G) The circulation of inert gas throughout the primary and the secondary insulation spaces, in accordance with **1101. 1** is to be sufficient to allow for effective means of gas detection.
- (2) Design considerations
- (A) Potential incidents that could lead to loss of fluid tightness over the life of the membranes are to be evaluated. These include, but are not limited to:
    - (a) Ultimate design events:
      - tensile failure of membranes;
      - compressive collapse of thermal insulation;
      - thermal ageing;
      - loss of attachment between thermal insulation and hull structure;
      - loss of attachment of membranes to thermal insulation system;
      - structural integrity of internal structures and their associated supporting structures; and
      - failure of the supporting hull structure.
    - (b) Fatigue design events:
      - fatigue of membranes including joints and attachments to hull structure;
      - fatigue cracking of thermal insulation;
      - fatigue of internal structures and their associated supporting structures; and
      - fatigue cracking of inner hull leading to ballast water ingress.
    - (c) Accident design events : Designs where a single internal event could cause simultaneous or cascading failure of both membranes are unacceptable.
      - accidental mechanical damage (such as dropped objects inside the tank while in service);
      - accidental over pressurization of thermal insulation spaces;
      - accidental vacuum in the tank; and
      - water ingress through the inner hull structure.

Designs where a single internal event could cause simultaneous or cascading failure of both membranes are unacceptable.

- (B) The necessary physical properties (mechanical, thermal, chemical, etc.) of the materials used in the construction of the liquefied gas fuel containment system is to be established during the design development in accordance with (1) (B).
- (3) Loads, load combinations  
Particular consideration is to be paid to the possible loss of tank integrity due to either an overpressure in the interbarrier space, a possible vacuum in the liquefied gas fuel tank, the sloshing effects, to hull vibration effects, or any combination of these events.
- (4) Structural analyses  
(A) Structural analyses and/or testing for the purpose of determining the ultimate strength and fatigue assessments of the liquefied gas fuel containment and associated structures and equipment noted in **407**. are to be performed. The structural analysis is to provide the data required to assess each failure mode that has been identified as critical for the liquefied gas fuel containment system.  
(B) Structural analyses of the hull are to take into account the internal pressure as indicated in **409. 3 (3) (A)**. Special attention is to be paid to deflections of the hull and their compatibility with the membrane and associated thermal insulation.  
(C) The analyses referred to in (A) and (B) are to be based on the particular motions, accelerations and response of ships and liquefied gas fuel containment systems.
- (5) Ultimate design condition  
(A) The structural resistance of every critical component, sub-system, or assembly, is to be established, in accordance with (1) (B), for in-service conditions.  
(B) The choice of strength acceptance criteria for the failure modes of the liquefied gas fuel containment system, its attachments to the hull structure and internal tank structures, is to reflect the consequences associated with the considered mode of failure.  
(C) The inner hull scantlings are to meet **Pt 3, Ch 15 of Rules for the classification of steel ships** for deep tanks, taking into account the internal pressure as indicated in **409. 3. (3) (A)** and the specified appropriate regulations for sloshing load as defined in **409. 4. (1) (C)**.
- (6) Fatigue design condition  
(A) Fatigue analysis is to be carried out for structures inside the tank, i.e. pump towers, and for parts of membrane and pump tower attachments, where failure development cannot be reliably detected by continuous monitoring.  
(B) The fatigue calculations are to be carried out in accordance with **412. 2**, with relevant regulations depending on:  
(a) the significance of the structural components with respect to structural integrity; and  
(b) availability for inspection.  
(C) For structural elements for which it can be demonstrated by tests and/or analyses that a crack will not develop to cause simultaneous or cascading failure of both membranes,  $C_W$  is to be less than or equal to 0.5.  
(D) Structural elements subject to periodic inspection, and where an unattended fatigue crack can develop to cause simultaneous or cascading failure of both membranes, is to satisfy the fatigue and fracture mechanics regulations stated in **412. 2 (8)**.  
(E) Structural element not accessible for in-service inspection, and where a fatigue crack can develop without warning to cause simultaneous or cascading failure of both membranes, is to satisfy the fatigue and fracture mechanics regulations stated in **412. 2 (9)**.
- (7) Accidental design condition  
(A) The containment system and the supporting hull structure are to be designed for the accidental loads specified in **409. 5**. These loads need not be combined with each other or with environmental loads.  
(B) Additional relevant accidental scenarios are to be determined based on a risk analysis. Particular attention is to be paid to securing devices inside of tanks.

#### 416. Limit state design for novel concepts

- Fuel containment systems that are of a novel configuration that cannot be designed using **415**. are to be designed using this section and **401. to 414.**, as applicable. Fuel containment system design according to this section is to be based on the principles of limit state design which is an approach to structural design that can be applied to established design solutions as well as novel

designs. This more generic approach maintains a level of safety similar to that achieved for known containment systems as designed using **415**.

## 2. Limit state design

- (1) The limit state design is a systematic approach where each structural element is evaluated with respect to possible failure modes related to the design conditions identified in **401. 6**. A limit state can be defined as a condition beyond which the structure, or part of a structure, no longer satisfies the regulations.
- (2) For each failure mode, one or more limit states may be relevant. By consideration of all relevant limit states, the limit load for the structural element is found as the minimum limit load resulting from all the relevant limit states. The limit states are divided into the three following categories:
  - (a) Ultimate limit states (ULS), which correspond to the maximum load-carrying capacity or, in some cases, to the maximum applicable strain or deformation; under intact (undamaged) conditions.
  - (b) Fatigue limit states (FLS), which correspond to degradation due to the effect of time varying (cyclic) loading.
  - (c) Accident limit states (ALS), which concern the ability of the structure to resist accidental situations.
- (3) The procedure and relevant design parameters of the limit state design are to comply with the Standards for the Use of limit state methodologies in the design of fuel containment systems of novel configuration (LSD Standard), as set out in the **Annex 2**.

## Section 5 Portable Liquefied Gas Fuel Tanks

### 501. Portable liquefied gas fuel tanks

1. The design of the tank is to comply with **415. 3**. The tank support (container frame or truck chassis) is to be designed for the intended purpose.
2. Portable fuel tanks are to be located in dedicated areas fitted with:
  - (1) mechanical protection of the tanks depending on location and cargo operations;
  - (2) if located on open deck: spill protection and water spray systems for cooling; and
  - (3) if located in an enclosed space: the space is to be considered as a tank connection space.
3. Portable fuel tanks are to be secured to the deck while connected to the ship systems. The arrangement for supporting and fixing the tanks are to be designed for the maximum expected static and dynamic inclinations, as well as the maximum expected values of acceleration, taking into account the ship characteristics and the position of the tanks.
4. Consideration is to be given to the strength and the effect of the portable fuel tanks on the ship's stability.
5. Connections to the ship's fuel piping systems are to be made by means of approved flexible hoses or other suitable means designed to provide sufficient flexibility.
6. Arrangements are to be provided to limit the quantity of fuel spilled in case of inadvertent disconnection or rupture of the non-permanent connections.
7. The pressure relief system of portable tanks is to be connected to a fixed venting system.
8. Control and monitoring systems for portable fuel tanks are to be integrated in the ship's control and monitoring system. Safety system for portable fuel tanks is to be integrated in the ship's safety system (e.g. shutdown systems for tank valves, leak/gas detection systems).
9. Safe access to tank connections for the purpose of inspection and maintenance is to be ensured.
10. After connection to the ship's fuel piping system,
  - (1) with the exception of the pressure relief system in **7** each portable tank is to be capable of being isolated at any time;
  - (2) isolation of one tank is not to impair the availability of the remaining portable tanks; and
  - (3) the tank is not to exceed its filling limits as given in **801**.

## Section 6 CNG Fuel Containment

### 601. CNG fuel containment

1. The storage tanks to be used for CNG is to be certified and approved by the Society.
2. Tanks for CNG are to be fitted with pressure relief valves with a set point below the design pressure of the tank and with outlet located as required in **702. 7** and **702. 8**.
3. Adequate means are to be provided to depressurize the tank in case of a fire which can affect the tank. **[See Guidance]**
4. Storage of CNG in enclosed spaces is normally not acceptable, but may be permitted after special consideration and approval by the Society provided the following is fulfilled in addition to **301. 4** to **301. 6** : **[See Guidance]**
  - (1) adequate means are provided to depressurize and inert the tank in case of a fire which can affect the tank;
  - (2) all surfaces within such enclosed spaces containing the CNG storage are provided with suitable thermal protection against any lost high-pressure gas and resulting condensation unless the bulk-heads are designed for the lowest temperature that can arise from gas expansion leakage; and
  - (3) a fixed fire-extinguishing system is installed in the enclosed spaces containing the CNG storage. Special consideration is to be given to the extinguishing of jet-fires.

## Section 7 Pressure Relief System

### 701. General

1. All fuel storage tanks are to be provided with a pressure relief system appropriate to the design of the fuel containment system and the fuel being carried. Fuel storage hold spaces, interbarrier spaces, tank connection spaces and tank cofferdams, which may be subject to pressures beyond their design capabilities, are to also be provided with a suitable pressure relief system. Pressure control systems specified in **901**. are to be independent of the pressure relief systems.
2. Fuel storage tanks which may be subject to external pressures above their design pressure is to be fitted with vacuum protection systems.

### 702. Pressure relief systems for liquefied gas fuel tanks

1. If fuel release into the vacuum space of a vacuum insulated tank cannot be excluded, the vacuum space is to be protected by a pressure relief device which is to be connected to a vent system if the tanks are located below deck. On open deck a direct release into the atmosphere may be accepted by the Society for tanks not exceeding the size of a 40 ft container if the released gas cannot enter safe areas.
2. Liquefied gas fuel tanks are to be fitted with a minimum of 2 pressure relief valves (PRVs) allowing for disconnection of one PRV in case of malfunction or leakage.
3. Interbarrier spaces are to be provided with pressure relief devices. For membrane systems, the designer is to demonstrate adequate sizing of interbarrier space PRVs. **[See Guidance]**
4. The setting of the PRVs is not to be higher than the vapour pressure that has been used in the design of the tank. Valves comprising not more than 50 % of the total relieving capacity may be set at a pressure up to 5 % above MARVS to allow sequential lifting, minimizing unnecessary release of vapour.
5. The following temperature regulations apply to PRVs fitted to pressure relief systems:
  - (1) PRVs on fuel tanks with a design temperature below 0 °C are to be designed and arranged to prevent their becoming inoperative due to ice formation;
  - (2) the effects of ice formation due to ambient temperatures are to be considered in the construction and arrangement of PRVs;
  - (3) PRVs are to be constructed of materials with a melting point above 925 °C. Lower melting point materials for internal parts and seals may be accepted provided that fail-safe operation of

- the PRV is not compromised; and
- (4) sensing and exhaust lines on pilot operated relief valves are to be of suitably robust construction to prevent damage.
6. In the event of a failure of a fuel tank PRV a safe means of emergency isolation are to be available.
    - (1) procedures are to be provided and included in the operation manual ;
    - (2) the procedures are to allow only one of the installed PRVs for the liquefied gas fuel tanks to be isolated, physical interlocks are to be included to this effect; and
    - (3) isolation of the PRV is to be carried out under the supervision of the master. This action is to be recorded in the ship's log, and at the PRV.
  7. Each pressure relief valve installed on a liquefied gas fuel tank is to be connected to a venting system, which is to be:
    - (1) so constructed that the discharge will be unimpeded and normally be directed vertically upwards at the exit;
    - (2) arranged to minimize the possibility of water or snow entering the vent system; and
    - (3) arranged such that the height of vent exits is normally not to be less than  $B/3$  or 6 m, whichever is the greater, above the weather deck and 6 m above working areas and walkways. However, vent mast height could be limited to lower value according to special consideration by the Society.
  8. The outlet from the pressure relief valves is to normally be located at least 10m from the nearest:
    - (1) air intake, air outlet or opening to accommodation, service and control spaces, or other non-hazardous area; and
    - (2) exhaust outlet from machinery installations.
  9. All other fuel gas vent outlets are to also be arranged in accordance with 7 and 8. Means are to be provided to prevent liquid overflow from gas vent outlets, due to hydrostatic pressure from spaces to which they are connected.
  10. In the vent piping system, means for draining liquid from places where it may accumulate is to be provided. The PRVs and piping are to be arranged so that liquid can, under no circumstances, accumulate in or near the PRVs.
  11. Suitable protection screens of not more than 13 mm square mesh are to be fitted on vent outlets to prevent the ingress of foreign objects without adversely affecting the flow.
  12. All vent piping are to be designed and arranged not to be damaged by the temperature variations to which it may be exposed, forces due to flow or the ship's motions.
  13. PRVs are to be connected to the highest part of the fuel tank. PRVs are to be positioned on the fuel tank so that they will remain in the vapour phase at the filling limit ( $FL$ ) as given in 801., under conditions of 15° list and 0.015 $L$  trim, where  $L$  is defined in Ch 1, 102. 25.

### 703. Sizing of pressure relieving system

#### 1. Sizing of pressure relief valves

- (1) PRVs are to have a combined relieving capacity for each liquefied gas fuel tank to discharge the greater of the following, with not more than a 20 % rise in liquefied gas fuel tank pressure above the MARVS:
  - (A) the maximum capacity of the liquefied gas fuel tank inerting system if the maximum attainable working pressure of the liquefied gas fuel tank inerting system exceeds the MARVS of the liquefied gas fuel tanks; or
  - (B) vapors generated under fire exposure computed using the following formula: **[See Guidance]**

$$Q = FGA^{0.82} \quad (\text{m}^3/\text{s})$$

where:

$Q$  = minimum required rate of discharge of air at standard conditions of 273.15 Kelvin (K) and 0.1013 MPa.

$F$  = fire exposure factor for different liquefied gas fuel types:

$F = 1.0$  for tanks without insulation located on deck;

$F = 0.5$  for tanks above the deck when insulation is approved by the Society. (Approval will be based on the use of a fireproofing material, the thermal conductance of insulation, and its stability under fire exposure);

$F = 0.5$  for uninsulated independent tanks installed in holds;

$F = 0.2$  for insulated independent tanks in holds (or uninsulated independent tanks in insulated holds);

$F = 0.1$  for insulated independent tanks in inerted holds (or uninsulated independent tanks in inerted, insulated holds); and

$F = 0.1$  for membrane tanks.

For independent tanks partly protruding through the weather decks, the fire exposure factor is to be determined on the basis of the surface areas above and below deck.

$G$  = gas factor according to formula:

$$G = \frac{12.4}{LD} \sqrt{\frac{ZT}{M}}$$

where:

$T$  = temperature in Kelvin at relieving conditions, i.e. 120 % of the pressure at which the pressure relief valve is set;

$L$  = latent heat of the material being vaporized at relieving conditions, in kJ/kg;

$D$  = a constant based on relation of specific heats  $k$  and is calculated as follows:

$$D = \sqrt{k \left( \frac{2}{k+1} \right)^{\frac{k+1}{k-1}}}$$

where:

$k$  = ratio of specific heats at relieving conditions, and the value of which is between 1.0 and 2.2.

If  $k$  is not known,  $D = 0.606$  is to be used;

$Z$  = compressibility factor of the gas at relieving conditions; if not known,  $Z = 1.0$  is to be used;

$M$  = molecular mass of the product.

The gas factor of each liquefied gas fuel to be carried is to be determined and the highest value is to be used for PRV sizing.

$A$  = external surface area of the tank ( $m^2$ ), as for different tank types, as shown in

**Fig 6.4.**

- (2) For vacuum insulated tanks in fuel storage hold spaces and for tanks in fuel storage hold spaces separated from potential fire loads by coffer dams or surrounded by ship spaces with no fire load the following applies:

If the pressure relief valves have to be sized for fire loads the fire factors according may be reduced to the following values: The minimum fire factor is  $F = 0.1$

$$F = 0.5 \text{ to } F = 0.25$$

$$F = 0.2 \text{ to } F = 0.1$$

- (3) The required mass flow of air at relieving conditions is given by: where density of air ( $\rho_{air}$ ) =  $1.293 \text{ kg/m}^3$  (air at 273.15 K, 0.1013 MPa).

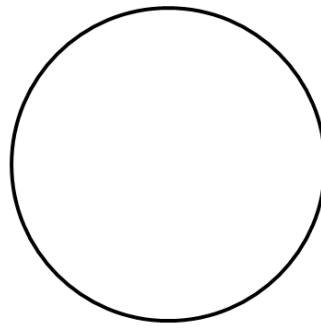

Cylindrical tanks with spherically dished hemispherical or semi-ellipsoidal heads or spherical tanks

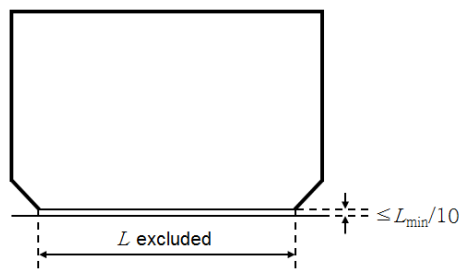

Prismatic tanks

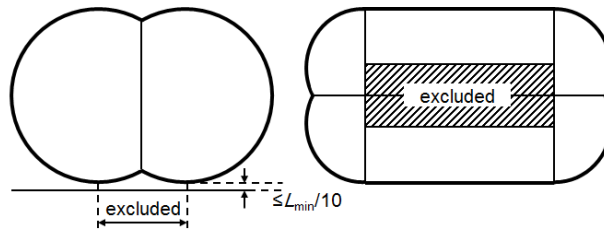

Bilobe tank

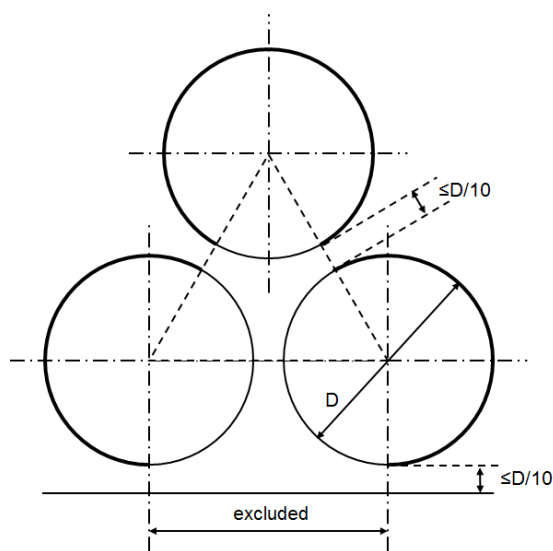

Horizontal cylindrical tanks arrangement

Fig 6.4 External surface area for different type of tank

## 2. Sizing of vent pipe system

- (1) Pressure losses upstream and downstream of the PRVs, are to be taken into account when determining their size to ensure the flow capacity required by 1.
- (2) Upstream pressure losses
  - (A) the pressure drop in the vent line from the tank to the PRV inlet is not to exceed 3 % of the valve set pressure at the calculated flow rate, in accordance with 1;
  - (B) pilot-operated PRVs are to be unaffected by inlet pipe pressure losses when the pilot senses directly from the tank dome; and
  - (C) pressure losses in remotely sensed pilot lines are to be considered for flowing type pilots.
- (3) Downstream pressure losses
  - (A) Where common vent headers and vent masts are fitted, calculations are to include flow from all attached PRVs.
  - (B) The built-up back pressure in the vent piping from the PRV outlet to the location of discharge to the atmosphere, and including any vent pipe interconnections that join other tanks, is not to exceed the following values:
    - (a) for unbalanced PRVs: 10 % of MARVS;
    - (b) for balanced PRVs: 30 % of MARVS; and
    - (c) for pilot operated PRVs: 50 % of MARVS.
 Alternative values provided by the PRV manufacturer may be accepted.
- (4) To ensure stable PRV operation, the blow-down is not to be less than the sum of the inlet pressure loss and 0.02 MARVS at the rated capacity.

## Section 8 Loading Limit for Liquefied Gas Fuel Tanks

### 801. Loading limit [See Guidance]

1. Storage tanks for liquefied gas are not to be filled to more than a volume equivalent to 98 % full at the reference temperature as defined in **Ch 1, 201. 36**. A loading limit curve for actual fuel loading temperatures is to be prepared from the following formula:

$$LL = FL \frac{\rho_R}{\rho_L}$$

where:

$LL$ (Loading limit) = loading limit as defined in **Ch 1, 201. 27**, expressed in per cent;

$FL$ (Filling limit) = filling limit as defined in **Ch 1, 201. 26** expressed in percent, here 98 %;

$\rho_R$  = relative density of fuel at the reference temperature; and

$\rho_L$  = relative density of fuel at the loading temperature

2. In cases where the tank insulation and tank location make the probability very small for the tank contents to be heated up due to an external fire, special considerations may be made to allow a higher loading limit than calculated using the reference temperature, but never above 95 %. This also applies in cases where a second system for pressure maintenance is installed, (refer to **901**). However, if the pressure can only be maintained / controlled by fuel consumers, the loading limit as calculated in **1** is to be used.

## Section 9 Maintaining of fuel storage condition

### 901. Control of tank pressure and temperature

1. With the exception of liquefied gas fuel tanks designed to withstand the full gauge vapour pressure of the fuel under conditions of the upper ambient design temperature, liquefied gas fuel tanks' pressure and temperature are to be maintained at all times within their design range by means acceptable to the Society, e.g. by one of the following methods: [See Guidance]

- (1) reliquefaction of vapours;
- (2) thermal oxidation of vapours;
- (3) pressure accumulation; or
- (4) liquefied gas fuel cooling.

The method chosen is to be capable of maintaining tank pressure below the set pressure of the tank pressure relief valves for a period of 15 days assuming full tank at normal service pressure and the ship in idle condition, i.e. only power for domestic load is generated.

2. Venting of fuel vapour for control of the tank pressure is not acceptable except in emergency situations.

### 902. Design of systems

1. For worldwide service, the upper ambient design temperature is to be sea 32 °C and air 45 °C. For service in particularly hot or cold zones, these design temperatures are to be increased or decreased, to the satisfaction of the Society.
2. The overall capacity of the system is to be such that it can control the pressure within the design conditions without venting to atmosphere.

### 903. Reliquefaction systems [See Guidance]

1. The reliquefaction system is to be designed and calculated according to 2. The system has to be sized in a sufficient way also in case of no or low consumption.
2. The reliquefaction system is to be arranged in one of the following ways:
  - (1) a direct system where evaporated fuel is compressed, condensed and returned to the fuel tanks;
  - (2) an indirect system where fuel or evaporated fuel is cooled or condensed by refrigerant without being compressed;
  - (3) a combined system where evaporated fuel is compressed and condensed in a fuel/refrigerant heat exchanger and returned to the fuel tanks; or
  - (4) if the reliquefaction system produces a waste stream containing methane during pressure control operations within the design conditions, these waste gases are to, as far as reasonably practicable, be disposed of without venting to atmosphere.

### 904. Thermal oxidation systems

Thermal oxidation can be done by either consumption of the vapours according to the regulations for consumers described in this Rules or in a dedicated gas combustion unit (GCU). It is to be demonstrated that the capacity of the oxidation system is sufficient to consume the required quantity of vapours. In this regard, periods of slow steaming and/or no consumption from propulsion or other services of the ship are to be considered.

### 905. Compatibility

Refrigerants or auxiliary agents used for refrigeration or cooling of fuel are to be compatible with the fuel they may come in contact with (not causing any hazardous reaction or excessively corrosive products). In addition, when several refrigerants or agents are used, these are to be compatible with each other.

### 906. Availability of systems

1. The availability of the system and its supporting auxiliary services are to be such that in case of a single failure (of mechanical non-static component or a component of the control systems) the fuel tank pressure and temperature can be maintained by another service/system.
2. Heat exchangers that are solely necessary for maintaining the pressure and temperature of the fuel tanks within their design ranges are to have a standby heat exchanger unless they have a capacity in excess of 25 % of the largest required capacity for pressure control and they can be repaired on board without external sources.

## Section 10 Atmosphere Control within the Fuel Containment System

### 1001. Atmosphere control within the fuel containment system

1. A piping system is to be arranged to enable each fuel tank to be safely gas-freed, and to be safely filled with fuel from a gas-free condition. The system is to be arranged to minimize the possibility of pockets of gas or air remaining after changing the atmosphere.
2. The system is to be designed to eliminate the possibility of a flammable mixture existing in the fuel tank during any part of the atmosphere change operation by utilizing an inerting medium as an intermediate step.
3. Gas sampling points are to be provided for each fuel tank to monitor the progress of atmosphere change.
4. Inert gas utilized for gas freeing of fuel tanks may be provided externally to the ship.

## Section 11 Atmosphere Control within Fuel Storage Hold Spaces (Fuel Containment Systems other than Type C Independent Tanks)

### 1101. Atmosphere control within fuel storage hold spaces (Fuel containment systems other than type C independent tanks)

1. Interbarrier and fuel storage hold spaces associated with liquefied gas fuel containment systems requiring full or partial secondary barriers are to be inerted with a suitable dry inert gas and kept inerted with make-up gas provided by a shipboard inert gas generation system, or by shipboard storage, which is to be sufficient for normal consumption for at least 30 days. Shorter periods may be considered by the Society depending on the ship's service.
2. Alternatively, the spaces referred to in **1** requiring only a partial secondary barrier may be filled with dry air provided that the ship maintains a stored charge of inert gas or is fitted with an inert gas generation system sufficient to inert the largest of these spaces, and provided that the configuration of the spaces and the relevant vapour detection systems, together with the capability of the inerting arrangements, ensures that any leakage from the liquefied gas fuel tanks will be rapidly detected and inerting effected before a dangerous condition can develop. Equipment for the provision of sufficient dry air of suitable quality to satisfy the expected demand is to be provided.

## Section 12 Environmental control of spaces surrounding type C independent tanks

### 1201. Environmental control of spaces surrounding type C independent tanks

Spaces surrounding liquefied gas fuel tanks are to be filled with suitable dry air and be maintained in this condition with dry air provided by suitable air drying equipment. This is only applicable for liquefied gas fuel tanks where condensation and icing due to cold surfaces is an issue.

## Section 13 Inerting

### 1301. Inerting [See Guidance]

1. Arrangements to prevent back-flow of fuel vapour into the inert gas system are to be provided as specified below.
2. To prevent the return of flammable gas to any non-hazardous spaces, the inert gas supply line is to be fitted with two shutoff valves in series with a venting valve in between (double block and bleed valves). In addition, a closable non-return valve is to be installed between the double block and bleed arrangement and the fuel system. These valves are to be located outside non-hazardous spaces.

3. Where the connections to the fuel piping systems are non-permanent, two non-return valves may be substituted for the valves required in 2.
4. The arrangements are to be such that each space being inerted can be isolated and the necessary controls and relief valves, etc. is to be provided for controlling pressure in these spaces.
5. Where insulation spaces are continually supplied with an inert gas as part of a leak detection system, means are to be provided to monitor the quantity of gas being supplied to individual spaces.

## **Section 14 Inert Gas Production and Storage on Board**

### **1401. Inert gas production and storage on board**

1. The equipment is to be capable of producing inert gas with oxygen content at no time greater than 5 % by volume. A continuous-reading oxygen content meter is to be fitted to the inert gas supply from the equipment and is to be fitted with an alarm set at a maximum of 5 % oxygen content by volume.
2. An inert gas system is to have pressure controls and monitoring arrangements appropriate to the fuel containment system.
3. Where a nitrogen generator or nitrogen storage facilities are installed in a separate compartment outside of the engine-room, the separate compartment is to be fitted with an independent mechanical extraction ventilation system, providing a minimum of 6 air changes per hour. A low oxygen alarm is to be fitted.
4. Nitrogen pipes are to only be led through well ventilated spaces. Nitrogen pipes in enclosed spaces is to:
  - (1) be fully welded;
  - (2) have only a minimum of flange connections as needed for fitting of valves; and
  - (3) be as short as possible. ↓

## CHAPTER 7 MATERIAL AND GENERAL PIPE DESIGN

### Section 1 General

#### 101. Goal

The goal of this Chapter is to ensure the safe handling of fuel, under all operating conditions, to minimize the risk to the ship, personnel and to the environment, having regard to the nature of the products involved.

### Section 2 Functional Requirements

#### 201. Functional requirements

This Chapter relates to functional requirements in **Ch 2, 201. 1, 5, 6, 8, 9 and 10**. In particular the following apply:

1. Fuel piping is to be capable of absorbing thermal expansion or contraction caused by extreme temperatures of the fuel without developing substantial stresses.
2. Provision is to be made to protect the piping, piping system and components and fuel tanks from excessive stresses due to thermal movement and from movements of the fuel tank and hull structure.
3. If the fuel gas contains heavier constituents that may condense in the system, means for safely removing the liquid are to be fitted.
4. Low temperature piping is to be thermally isolated from the adjacent hull structure, where necessary, to prevent the temperature of the hull from falling below the design temperature of the hull material.

### Section 3 Pipe design

#### 301. General

1. Fuel pipes and all the other piping needed for a safe and reliable operation and maintenance are to be colour marked in accordance with a standard recognized by the Society. **[See Guidance]**
2. Where tanks or piping are separated from the ship's structure by thermal isolation, provision is to be made for electrically bonding to the ship's structure both the piping and the tanks. All gasketed pipe joints and hose connections are to be electrically bonded.
3. All pipelines or components which may be isolated in a liquid full condition are to be provided with relief valves.
4. Pipework, which may contain low temperature fuel, is to be thermally insulated to an extent which will minimize condensation of moisture.
5. Piping other than fuel supply piping and cabling may be arranged in the double wall piping or duct provided that they do not create a source of ignition or compromise the integrity of the double pipe or duct. The double wall piping or duct is only to contain piping or cabling necessary for operational purposes.

#### 302. Wall thickness **[See Guidance]**

1. The minimum wall thickness is to be calculated as follows:

$$t = \frac{t_0 + b + c}{1 - \frac{a}{100}} \quad (\text{mm})$$

where:

$t_0$  = theoretical thickness (mm), determined by the following formula:

$$t_0 = \frac{PD}{2K_e + P}$$

with:

$P$  = design pressure (MPa) referred to in **303**.

$D$  = outside diameter of pipe (mm)

$K$  = allowable stress (N/mm<sup>2</sup>) referred to in **304**.

$e$  = efficiency factor equal to 1.0 for seamless pipes and for longitudinally or spirally welded pipes, delivered by approved manufacturers of welded pipes, which are considered equivalent to seamless pipes when non-destructive testing on welds is carried out in accordance with Recognized Standards. In other cases an efficiency factor of less than 1.0, in accordance with recognized standards, may be required depending on the manufacturing process.

$b$  = allowance for bending (mm). The value of  $b$  is to be chosen so that the calculated stress in the bend, due to internal pressure only, does not exceed the allowable stress.

Where such justification is not given,  $b$  is to be:

$$b = \frac{Dt_0}{2.5r}$$

with :

$r$  = mean radius of the bend (mm)

$c$  = corrosion allowance (mm). If corrosion or erosion is expected, the wall thickness of the piping is to be increased over that required by other design requirements. This allowance is to be consistent with the expected life of the piping.

$a$  = negative manufacturing tolerance of thickness (%).

2. The absolute minimum wall thickness is to be in accordance with a standard acceptable to the Society.

### 303. Design condition

1. The greater of the following design conditions is to be used for piping, piping system and components as appropriate:
  - (1) for systems or components which may be separated from their relief valves and which contain only vapour at all times, vapour pressure at 45 °C assuming an initial condition of saturated vapour in the system at the system operating pressure and temperature; or **[See Guidance]**
  - (2) the MARVS of the fuel tanks and fuel processing systems; or
  - (3) the pressure setting of the associated pump or compressor discharge relief valve; or
  - (4) the maximum total discharge or loading head of the fuel piping system; or
  - (5) the relief valve setting on a pipeline system.
2. Piping, piping systems and components are to have a minimum design pressure of 1.0 MPa except for open ended lines where it is not to be less than 0.5 MPa.

### 304. Allowable stress

1. For pipes made of steel including stainless steel, the allowable stress to be considered in the formula of the strength thickness in **302. 1** is to be the lower of the following values:

$$R_m/2.7 \quad \text{or} \quad R_e/1.8$$

where:

$R_m$  = specified minimum tensile strength at room temperature (N/mm<sup>2</sup>)

$R_e$  = specified minimum yield stress or 0.2 % proof stress at room temperature (N/mm<sup>2</sup>)

2. Where necessary for mechanical strength to prevent damage, collapse, excessive sag or buckling of pipes due to superimposed loads, the wall thickness is to be increased over that required by **302. 1**, or, if this is impracticable or would cause excessive local stresses, these loads are to be reduced, protected against or eliminated by other design methods. Such superimposed loads may be due to; supports, ship deflections, liquid pressure surge during transfer operations, the weight of suspended valves, reaction to loading arm connections, or otherwise.
3. For pipes made of materials other than steel, the allowable stress is to be considered by the Society.
4. High pressure fuel piping systems are to have sufficient constructive strength. This is to be confirmed by carrying out stress analysis and taking into account:
  - (1) stresses due to the weight of the piping system;
  - (2) acceleration loads when significant; and
  - (3) internal pressure and loads induced by hog and sag of the ship.
5. When the design temperature is minus 110 °C or colder, a complete stress analysis, taking into account all the stresses due to weight of pipes, including acceleration loads if significant, internal pressure, thermal contraction and loads induced by hog and sag of the ship is to be carried out for each branch of the piping system.

### 305. Flexibility of piping

The arrangement and installation of fuel piping are to provide the necessary flexibility to maintain the integrity of the piping system in the actual service situations, taking potential for fatigue into account.

### 306. Piping fabrication and joining details [See Guidance]

1. Flanges, valves and other fittings are to comply with a standard acceptable to the Society, taking into account the design pressure defined in **303. 1**. For bellows and expansion joints used in vapour service, a lower minimum design pressure than defined in **303. 1** may be accepted.
2. All valves and expansion joints used in high pressure fuel piping systems are to be approved according to a standard acceptable to the Society.
3. The piping system is to be joined by welding with a minimum of flange connections. Gaskets are to be protected against blow-out.
4. Piping fabrication and joining details are to comply with the following:
  - (1) Direct connections
    - (A) Butt-welded joints with complete penetration at the root may be used in all applications. For design temperatures colder than minus 10 °C, butt welds are to be either double welded or equivalent to a double welded butt joint. This may be accomplished by use of a backing ring, consumable insert or inert gas back-up on the first pass. For design pressures in excess of 1.0 MPa and design temperatures of minus 10 °C or colder, backing rings are to be removed.
    - (B) Slip-on welded joints with sleeves and related welding, having dimensions in accordance with recognized standards, are to only be used for instrument lines and open-ended lines with an external diameter of 50 mm or less and design temperatures not colder than minus 55 °C.

- (C) Screwed couplings complying with recognized standards are to only be used for accessory lines and instrumentation lines with external diameters of 25 mm or less.
- (2) Flanged connections
- (A) Flanges in flange connections are to be of the welded neck, slip-on or socket welded type; and
- (B) For all piping except open ended, the following restrictions apply:
- (a) For design temperatures colder than minus 55 °C, only welded neck flanges are to be used; and
- (b) For design temperatures colder than minus 10 °C, slip-on flanges are not to be used in nominal sizes above 100 mm and socket welded flanges are not to be used in nominal sizes above 50 mm.
- (3) Expansion joints
- Where bellows and expansion joints are provided in accordance with 1 the following apply:
- (A) if necessary, bellows are to be protected against icing;
- (B) slip joints are not to be used except within the liquefied gas fuel storage tanks; and
- (C) bellows are normally not to be arranged in enclosed spaces.
- (4) Other connections
- Piping connections are to be joined in accordance with (1) to (3) but for other exceptional cases, the Society may consider alternative arrangements.

## Section 4 Materials

### 401. Metallic materials

- Materials for fuel containment and piping systems are to comply with the minimum regulations given in the following tables:
  - Table 7.1:** Plates, pipes (seamless and welded), sections and forgings for fuel tanks and process pressure vessels for design temperatures not lower than 0 °C.
  - Table 7.2:** Plates, sections and forgings for fuel tanks, secondary barriers and process pressure vessels for design temperatures below 0 °C and down to minus 55 °C.
  - Table 7.3:** Plates, sections and forgings for fuel tanks, secondary barriers and process pressure vessels for design temperatures below minus 55 °C and down to minus 165 °C.
  - Table 7.4:** Pipes (seamless and welded), forgings and castings for fuel and process piping for design temperatures below 0 °C and down to minus 165 °C.
  - Table 7.5:** Plates and sections for hull structures required by **Ch 6, 413. 1 (2)**.
- Materials having a melting point below 925 °C are not to be used for piping outside the fuel tanks.
- For CNG tanks, the use of materials not covered above may be specially considered by the Society.
- Where required the outer pipe or duct containing high pressure gas in the inner pipe is as a minimum to fulfil the material requirements for pipe materials with design temperature down to minus 55 °C in **Table 7.4**.
- The outer pipe or duct around liquefied gas fuel pipes is as a minimum to fulfil the material regulations for pipe materials with design temperature down to minus 165 °C in **Table 7.4**.

**Table 7.1 PLATES, PIPES (SEAMLESS AND WELDED)<sup>(1)(2)</sup>, SECTIONS AND FORGINGS FOR FUEL TANKS AND PROCESS PRESSURE VESSELS FOR DESIGN TEMPERATURES NOT LOWER THAN 0 °C. [See Guidance]**

<b>1. CHEMICAL COMPOSITION AND HEAT TREATMENT</b>		
<ul style="list-style-type: none"> <li>- Carbon-manganese steel, Fully killed fine grain steel</li> <li>- Small additions of alloying elements by agreement with the Society</li> <li>- Composition limits to be approved by the Society</li> <li>- Normalized, or quenched and tempered<sup>(4)</sup></li> </ul>		
<b>2. TENSILE AND TOUGHNESS (IMPACT) TEST REQUIREMENTS</b>		
<b>2.1 frequency</b>		
Plates	Each "piece" to be tested	
Sections and forgings	Each "batch" to be tested	
<b>2.2 Mechanical properties</b>		
Tensile properties	Specified minimum yield stress not to exceed 410 N/mm <sup>2</sup> <sup>(5)</sup>	
<b>2.3 Toughness (Charpy V-notch test)</b>		
Plates	Transverse test pieces. Minimum average energy value (KV) 27J	
Sections and forgings	Longitudinal test pieces. Minimum average energy value (KV) 41J	
Test temperature	Thickness $t$ (mm)	Test temperature (°C)
	$t \leq 20$	0
	$20 < t \leq 40$ <sup>(3)</sup>	-20
<p>Notes:</p> <p>(1) For seamless pipes and fittings normal practice applies. The use of longitudinally and spirally welded pipes is to be specially approved by the Society.</p> <p>(2) Charpy V-notch impact tests are not required for pipes.</p> <p>(3) This table is generally applicable for material thicknesses up to 40 mm. Proposals for greater thicknesses are to be approved by the Society.</p> <p>(4) A controlled rolling procedure or TMCP may be used as an alternative.</p> <p>(5) Materials with specified minimum yield stress exceeding 410 N/mm<sup>2</sup> may be specially approved by the Society. For these materials, particular attention is to be given to the hardness of the welded and heat affected zone.</p>		

**Table 7.2 PLATES, SECTIONS AND FORGINGS<sup>(1)</sup> FOR FUEL TANKS, SECONDARY BARRIERS AND PROCESS PRESSURE VESSELS FOR DESIGN TEMPERATURES BELOW 0 °C AND DOWN TO -55 °C. Maximum thickness 25 mm<sup>(2)</sup> [See Guidance]**

1. CHEMICAL COMPOSITION AND HEAT TREATMENT					
- Carbon-manganese steel, Fully killed, aluminium treated fine grain steel					
- Chemical composition (ladle analysis)					
C	Mn	Si	S	P	
0.16 % max. <sup>(3)</sup>	0.70 ~ 1.60 %	0.10-0.50 %	0.025 % max.	0.025 % max.	
- Optional additions: Alloys and grain refining elements may be generally in accordance with the following:					
Ni	Cr	Mo	Cu	Nb	V
0.80 % max.	0.25 % max.	0.08 % max.	0.35 % max	0.05 % max.	0.10 % max.
- Al content total 0.02 % min (Acid soluble 0.015 % min)					
- Normalized or quenched and tempered <sup>(4)</sup>					
2. TENSILE AND TOUGHNESS (IMPACT) TEST REQUIREMENTS					
2.1 Sampling frequency					
Plates	Each "piece" to be tested				
Sections and forgings	Each "batch" to be tested				
2.2 Mechanical properties					
Tensile properties	Specified minimum yield stress not to exceed 410 N/mm <sup>2</sup> <sup>(5)</sup>				
2.3 Toughness (Charpy V-notch test)					
Plates	Transverse test pieces. Minimum average energy value (KV) 27J				
Sections and forgings	Longitudinal test pieces. Minimum average energy value (KV) 41J				
Test temperature	5 °C below the design temperature or -20 °C whichever is lower				
Notes:					
(1) The Charpy V-notch and chemistry requirements for forgings may be specially considered by the Society.					
(2) For material thickness of more than 25 mm, Charpy V-notch tests are to be conducted as follows:					
Material thickness (mm)		Test temperature (°C)			
25 < t ≤ 30		10 °C below design temperature or -20 °C, whichever is lower			
30 < t ≤ 35		15 °C below design temperature or -20 °C, whichever is lower			
35 < t ≤ 40		20 °C below design temperature			
40 < t		Temperature approved by the Society			
The impact energy value is to be in accordance with the table for the applicable type of test specimen. Materials for tanks and parts of tanks which are completely thermally stress relieved after welding may be tested at a temperature 5 °C below design temperature or -20 °C, whichever is lower. For thermally stress relieved reinforcements and other fittings, the test temperature is to be the same as that required for the adjacent tank-shell thickness.					
(3) By special agreement with the Society, the carbon content may be increased to 0.18 % maximum, provided the design temperature is not lower than -40 °C.					
(4) A controlled rolling procedure or TMCP may be used as an alternative.					
(5) Materials with specified minimum yield stress exceeding 410 N/mm <sup>2</sup> may be approved by the Society. For these materials, particular attention is to be given to the welded and heat affected zones.					
<b>Guidance:</b>					
For materials exceeding 25 mm in thickness for which the test temperature is -60 °C or lower, the application of specially treated steels or steels in accordance with <b>Table 7.3</b> may be necessary.					

**Table 7.3 PLATES, SECTIONS AND FORGINGS<sup>(1)</sup> FOR FUEL TANKS, SECONDARY BARRIERS AND PROCESS PRESSURE VESSELS FOR DESIGN TEMPERATURES BELOW -55 °C AND DOWN TO -165 °C<sup>(2)</sup>. Maximum thickness 25 mm<sup>(3)(4)</sup> [See Guidance]**

Minimum design temp. (°C)	Chemical composition <sup>(5)</sup> and heat treatment	Impact test temp.(°C)
-60	1.5 % nickel steel - normalized or normalized and tempered or quenched and tempered or TMCP <sup>(6)</sup>	-65
-65	2.25 % nickel steel - normalized or normalized and tempered or quenched and tempered or TMCP <sup>(6)(7)</sup>	-70
-90	3.5 % nickel steel - normalized or normalized and tempered or quenched and tempered or TMCP <sup>(6)(7)</sup>	-95
-105	5 % nickel steel - normalized or normalized and tempered or quenched and tempered or TMCP <sup>(6)(7)</sup>	-110
-165	9 % nickel steel - double normalized and tempered or quenched and tempered <sup>(6)</sup>	-196
-165	Austenitic steels, such as types 304, 304 L, 316, 316 L, 321 and 347 solution treated <sup>(9)</sup>	-196
-165	Aluminium alloys; such as type 5083 annealed	Not required
-165	Austenitic Fe-Ni alloy (36 % nickel). Heat treatment as agreed	Not required

#### 1. TENSILE AND TOUGHNESS (IMPACT) TEST REQUIREMENTS

##### 1.1 Sampling frequency

Plates	Each "piece" to be tested
Sections and forgings	Each "batch" to be tested

##### 1.2 Toughness (Charpy V-notch test)

Plates	Transverse test pieces. Minimum average energy value (KV) 27J
Sections and forgings	Longitudinal test pieces. Minimum average energy value (KV) 41J

#### Notes:

- (1) The impact test required for forgings used in critical applications is to be subject to special consideration by the Society.
- (2) The requirements for design temperatures below -165 °C are to be specially agreed with the Society.
- (3) For materials 1.5 % Ni, 2.25 % Ni, 3.5 % Ni and 5 % Ni, with thicknesses greater than 25 mm, the impact tests are to be conducted as follows:

Material thickness (mm)	Test temperature
$25 < t \leq 30$	10 °C below design temperature
$30 < t \leq 35$	15 °C below design temperature
$35 < t \leq 40$	20 °C below design temperature

The energy value is to be in accordance with the table for the applicable type of test specimen. For material thickness of more than 40 mm, the Charpy V-notch values are to be specially considered.

- (4) For 9 % Ni, austenitic stainless steels and aluminium alloys, thicknesses greater than 25 mm may be used.
- (5) The chemical composition limits are to be in accordance with **Pt 2 Ch 1 of Rules for the classification of steel ships** or standards deemed appropriate by the our Society.
- (6) TMCP nickel steels will be subject to acceptance by the Society.
- (7) A lower minimum design temperature for quenched and tempered steels may be specially agreed with the Society.
- (8) A specially heat treated 5 % nickel steel, for example triple heat treated 5 % nickel steel, may be used down to -165 °C, provided that the impact tests are carried out at -196 °C.
- (9) The impact test may be omitted, subject to agreement with the Society.

**Table 7.4 PIPES (SEAMLESS AND WELDED)<sup>(1)</sup>, FORGINGS<sup>(2)</sup> AND CASTINGS<sup>(2)</sup> FOR FUEL AND PROCESS PIPING FOR DESIGN TEMPERATURES BELOW 0 °C AND DOWN TO -165 °C<sup>(3)</sup> Maximum thickness 25 mm [See Guidance]**

Minimum design temp. (°C)	Chemical composition <sup>(5)</sup> and heat treatment	Impact test	
		Test temp.(°C)	Minimum average energy (KV)(J)
-55	Carbon-manganese steel. Fully killed fine grain. Normalized or as agreed <sup>(6)</sup>	(4)	27
-65	2.25 % nickel steel. Normalized or normalized and tempered or quenched and tempered <sup>(6)</sup>	-70	34
-90	3.5 % nickel steel. Normalized or normalized and tempered or quenched and tempered <sup>(6)</sup>	-95	34
-165	9 % nickel steel <sup>(7)</sup> . Double normalized and tempered or quenched and tempered	-196	41
	Austenitic steels, such as types 304, 304 L, 316, 316 L, 321 and 347. Solution treated <sup>(8)</sup>	-196	41
	Aluminium alloys, such as type 5083 annealed	-	Not required
<b>1. TENSILE AND TOUGHNESS (IMPACT) TEST REQUIREMENTS</b>			
<b>1.1 Sampling frequency</b>			
- Each batch to be tested			
<b>1.2 Toughness (Charpy V-notch test)</b>			
- Impact test: Longitudinal test pieces			
Notes:			
(1) The use of longitudinally or spirally welded pipes is to be specially approved by the Society.			
(2) The requirements for forgings and castings may be subject to special consideration by the Society.			
(3) The requirements for design temperatures below -165 °C are to be specially agreed with the Society.			
(4) The test temperature is to be 5 °C below the design temperature or -20 °C, whichever is lower.			
(5) The composition limits are to be in accordance with <b>Pt 2 Ch 1 of Rules for the classification of steel ships</b> or standards deemed appropriate by the our Society.			
(6) A lower design temperature may be specially agreed with the Society for quenched and tempered materials.			
(7) This chemical composition is not suitable for castings.			
(8) Impact tests may be omitted, subject to agreement with the Society.			

**Table 7.5 PLATES AND SECTIONS FOR HULL STRUCTURES REQUIRED BY Ch 6, 413. 1 (2)**

[See Guidance] ↓

Minimum design temperature of hull structure (°C)	Maximum thickness (mm) for steel grades							
	A	B	D	E	AH	DH	EH	FH
0 and above	standards deemed appropriate by the our Society							
down to -5	15	25	30	50	25	45	50	50
down to -10	×	20	25	50	20	40	50	50
down to -20	×	×	20	50	×	30	50	50
down to -30	×	×	×	40	×	20	40	50
Below -30	In accordance with <b>Table 7.2</b> except that the thickness limitation given in <b>Table 7.2</b> and in note (2) of that table does not apply.							
Notes:								
"x" means steel grade not to be used.								

## CHAPTER 8 BUNKERING

### Section 1 Goal

#### 101. Goal

The goal of this Chapter is to provide for suitable systems on board the ship to ensure that bunkering can be conducted without causing danger to persons, the environment or the ship.

### Section 2 Functional Requirements

#### 201. Functional requirements

This Chapter relates to functional requirements in **Ch 2, 201. 1 to 11, 13 to 17**. In particular the following apply:

1. The piping system for transfer of fuel to the storage tank is to be designed such that any leakage from the piping system cannot cause danger to personnel, the environment or the ship.

### Section 3 Bunkering Station

#### 301. General requirements

1. The bunkering station is to be located on open deck so that sufficient natural ventilation is provided. Closed or semi-enclosed bunkering stations are to be subject to special consideration within the risk assessment. **[See Guidance]**
2. Connections and piping are to be so positioned and arranged that any damage to the fuel piping does not cause damage to the ship's fuel containment system resulting in an uncontrolled gas discharge.
3. Arrangements are to be made for safe management of any spilled fuel.
4. Suitable means are to be provided to relieve the pressure and remove liquid contents from pump suctions and bunker lines. Liquid is to be discharged to the liquefied gas fuel tanks or other suitable location.
5. The surrounding hull or deck structures are not to be exposed to unacceptable cooling, in case of leakage of fuel.
6. For CNG bunkering stations, low temperature steel shielding is to be considered to determine if the escape of cold jets impinging on surrounding hull structure is possible.

#### 302. Ships' fuel hoses

1. Liquid and vapour hoses used for fuel transfer are to be compatible with the fuel and suitable for the fuel temperature.
2. Hoses subject to tank pressure, or the discharge pressure of pumps or vapour compressors, are to be designed for a bursting pressure not less than five times the maximum pressure the hose can be subjected to during bunkering.

## Section 4 Manifold

### 401. Manifold

The bunkering manifold is to be designed to withstand the external loads during bunkering. The connections at the bunkering station are to be of dry-disconnect type equipped with additional safety dry break-away coupling/self-sealing quick release. The couplings are to be of a standard type.

## Section 5 Bunkering System

### 501. Bunkering system [See Guidance]

1. An arrangement for purging fuel bunkering lines with inert gas is to be provided.
2. The bunkering system is to be so arranged that no gas is discharged to the atmosphere during filling of storage tanks.
3. A manually operated stop valve and a remote operated shutdown valve in series, or a combined manually operated and remote valve are to be fitted in every bunkering line close to the connecting point. It is to be possible to operate the remote valve in the control location for bunkering operations and/or from another safe location.
4. Means are to be provided for draining any fuel from the bunkering pipes upon completion of operation.
5. Bunkering lines are to be arranged for inerting and gas freeing. When not engaged in bunkering, the bunkering pipes are to be free of gas, unless the consequences of not gas freeing is evaluated and approved.
6. In case bunkering lines are arranged with a cross-over it is to be ensured by suitable isolation arrangements that no fuel is transferred inadvertently to the ship side not in use for bunkering.
7. A ship-shore link (SSL) or an equivalent means for automatic and manual ESD communication to the bunkering source is to be fitted.
8. If not demonstrated to be required at a higher value due to pressure surge considerations, a default time as calculated in accordance with **Ch 16, 703. 7** from the trigger of the alarm to full closure of the remote operated valve required by **3** is to be adjusted.⌵

## CHAPTER 9 FUEL SUPPLY TO CONSUMERS

### Section 1 Goal

#### 101. Goal

The goal of this Chapter is to ensure safe and reliable distribution of fuel to the consumers.

### Section 2 Functional Requirements

#### 201. Functional requirements

This Chapter is related to functional requirements in **Ch 2, 201. 1 to 6, 8 to 11 and 13 to 17**. In particular the following apply:

1. the fuel supply system is to be so arranged that the consequences of any release of fuel will be minimized, while providing safe access for operation and inspection;
2. the piping system for fuel transfer to the consumers is to be designed in a way that a failure of one barrier cannot lead to a leak from the piping system into the surrounding area causing danger to the persons on board, the environment or the ship; and
3. fuel lines outside the machinery spaces are to be installed and protected so as to minimize the risk of injury to personnel and damage to the ship in case of leakage.

### Section 3 Redundancy of Fuel Supply

#### 301. Redundancy of fuel supply

1. For single fuel installations the fuel supply system is to be arranged with full redundancy and segregation all the way from the fuel tanks to the consumer, so that a leakage in one system does not lead to an unacceptable loss of power.
2. For single fuel installations, the fuel storage is to be divided between two or more tanks. The tanks are to be located in separate compartments.
3. For type C tank only, one tank may be accepted if two completely separate tank connection spaces are installed for the one tank.

### Section 4 Safety Functions of Gas Supply System

#### 401. Safety functions of gas supply system

1. Fuel storage tank inlets and outlets are to be provided with valves located as close to the tank as possible. Valves required to be operated during normal operation which are not accessible are to be remotely operated. Normal operation in this context is when gas is supplied to consumers and during bunkering operations. Tank valves whether accessible or not are to be automatically operated when the safety system required in **Ch 15 202. 2** is activated. **[See Guidance]**
2. The main gas supply line to each gas consumer or set of consumers is to be equipped with a manually operated stop valve and an automatically operated "master gas fuel valve" coupled in series or a combined manually and automatically operated valve. The valves are to be situated in the part of the piping that is outside the machinery space containing gas consumers, and placed as near as possible to the installation for heating the gas, if fitted. The master gas fuel valve is automatically to cut off the gas supply when activated by the safety system required in **Ch 15, 202. 2**.
3. The automatic master gas fuel valve is to be operable from safe locations on escape routes inside a machinery space containing a gas consumer, the engine control room, if applicable; outside the machinery space, and from the navigation bridge.

4. Each gas consumer is to be provided with "double block and bleed" valves arrangement. These valves are to be arranged as outlined in (1) or (2) so that when the safety system required in **Ch 15, 202. 2** is activated this will cause the shutoff valves that are in series to close automatically and the bleed valve to open automatically and:
  - (1) the two shutoff valves are to be in series in the gas fuel pipe to the gas consuming equipment. The bleed valve is to be in a pipe that vents to a safe location in the open air that portion of the gas fuel piping that is between the two valves in series; or
  - (2) the function of one of the shutoff valves in series and the bleed valve can be incorporated into one valve body, so arranged that the flow to the gas utilization unit will be blocked and the ventilation opened.
5. The two valves are to be of the fail-to-close type, while the ventilation valve is to be fail-to-open.
6. The double block and bleed valves are also to be used for normal stop of the engine.
7. In cases where the master gas fuel valve is automatically shutdown, the complete gas supply branch downstream of the double block and bleed valve are to be automatically ventilated assuming reverse flow from the engine to the pipe.
8. There is to be one manually operated shutdown valve in the gas supply line to each engine upstream of the double block and bleed valves to assure safe isolation during maintenance on the engine.
9. For single-engine installations and multi-engine installations, where a separate master valve is provided for each engine, the master gas fuel valve and the double block and bleed valve functions can be combined.
10. For each main gas supply line entering an ESD protected machinery space, and each gas supply line to high pressure installations means is to be provided for rapid detection of a rupture in the gas line in the engine-room. When rupture is detected a valve is to be automatically shut off. This valve is to be located in the gas supply line before it enters the engine-room or as close as possible to the point of entry inside the engine-room. It can be a separate valve or combined with other functions, e.g. the master valve.

## Section 5 Fuel Distribution Outside of Machinery Space

### 501. Fuel distribution outside of machinery space

1. Where fuel pipes pass through enclosed spaces in the ship, they are to be protected by a secondary enclosure. This enclosure can be a ventilated duct or a double wall piping system. The duct or double wall piping system is to be mechanically underpressure ventilated with 30 air changes per hour, and gas detection as required in **Ch 15, 801.** is to be provided. Other solutions providing an equivalent safety level may also be accepted by the Society. **[See Guidance]**
2. The requirement in 1 need not be applied for fully welded fuel gas vent pipes led through mechanically ventilated spaces.

## Section 6 Fuel Supply to Consumers in Gas-safe Machinery Spaces

### 601. Fuel supply to consumers in gas-safe machinery spaces

1. Fuel piping in gas-safe machinery spaces are to be completely enclosed by a double pipe or duct fulfilling one of the following conditions:
  - (1) the gas piping is to be a double wall piping system with the gas fuel contained in the inner pipe. The space between the concentric pipes is to be pressurized with inert gas at a pressure greater than the gas fuel pressure. Suitable alarms are to be provided to indicate a loss of inert gas pressure between the pipes. When the inner pipe contains high pressure gas, the system is to be so arranged that the pipe between the master gas valve and the engine is automatically purged with inert gas when the master gas valve is closed; or
  - (2) the gas fuel piping is to be installed within a ventilated pipe or duct. The air space between

- the gas fuel piping and the wall of the outer pipe or duct is to be equipped with mechanical underpressure ventilation having a capacity of at least 30 air changes per hour. This ventilation capacity may be reduced to 10 air changes per hour provided automatic filling of the duct with nitrogen upon detection of gas is arranged for. The fan motors are to comply with the required explosion protection in the installation area. The ventilation outlet is to be covered by a protection screen and placed in a position where no flammable gas-air mixture may be ignited; or
- (3) other solutions providing an equivalent safety level may also be accepted by the Society.

**[See Guidance]**

2. The connecting of gas piping and ducting to the gas injection valves is to be completely covered by the ducting. The arrangement is to facilitate replacement and/or overhaul of injection valves and cylinder covers. The double ducting is also required for all gas pipes on the engine itself, until gas is injected into the chamber. **[See Guidance]**

## Section 7 Fuel Supply to Consumers in ESD-protected Machinery Spaces

### 701. Fuel supply to consumers in ESD-protected machinery spaces

1. The pressure in the gas fuel supply system is not to exceed 1.0 MPa.
2. The gas fuel supply lines are to have a design pressure not less than 1.0 MPa.

## Section 8 Design of Ventilated Duct, Outer Pipe Against Inner Pipe Gas Leakage

### 801. Design of ventilated duct, outer pipe against inner pipe gas leakage

The design pressure of the outer pipe or duct of fuel systems is not to be less than the maximum working pressure of the inner pipe. Alternatively for fuel piping systems with a working pressure greater than 1.0 MPa, the design pressure of the outer pipe or duct is not to be less than the maximum built-up pressure arising in the annular space considering the local instantaneous peak pressure in way of any rupture and the ventilation arrangements.

### 802. Design pressure of high-pressure fuel piping

1. For high-pressure fuel piping the design pressure of the ducting is to be taken as the higher of the following:
  - (1) the maximum built-up pressure: static pressure in way of the rupture resulting from the gas flowing in the annular space;
  - (2) local instantaneous peak pressure in way of the rupture: this pressure is to be taken as the critical pressure given by the following expression:

$$p = p_0 \left( \frac{2}{k+1} \right)^{\frac{k}{k-1}}$$

where:

$p_0$  = maximum working pressure of the inner pipe

$k = C_p/C_v$  constant pressure specific heat divided by the constant volume specific heat  
(1.31 for CH<sub>4</sub>)

2. The tangential membrane stress of a straight pipe is not to exceed the tensile strength divided by 1.5 ( $R_m/1.5$ ) when subjected to the above pressures. The pressure ratings of all other piping components are to reflect the same level of strength as straight pipes.
3. As an alternative to using the peak pressure from the above formula, the peak pressure found from representative tests can be used. Test reports are then to be submitted.

**803. Verification of the strength**

Verification of the strength is to be based on calculations demonstrating the duct or pipe integrity. As an alternative to calculations, the strength can be verified by representative tests.

**804. Testing and Dimension of Ducts**

For low pressure fuel piping the duct is to be dimensioned for a design pressure not less than the maximum working pressure of the fuel pipes. The duct is to be pressure tested to show that it can withstand the expected maximum pressure at fuel pipe rupture.

## Section 9 Compressors and Pumps

**901. Bulkhead penetration**

If compressors or pumps are driven by shafting passing through a bulkhead or deck, the bulkhead penetration is to be of gastight type.

**902. Compressors and pumps**

Compressors and pumps are to be suitable for their intended purpose. All equipment and machinery are to be such as to be adequately tested to ensure suitability for use within a marine environment. Such items to be considered would include, but not be limited to:

1. environmental;
2. shipboard vibrations and accelerations;
3. effects of pitch, heave and roll motions, etc.; and
4. gas composition.

**903. Introduction prevention of liquefied gas**

Arrangements are to be made to ensure that under no circumstances liquefied gas can be introduced in the gas control section or gas-fuelled machinery, unless the machinery is designed to operate with gas in liquid state.

**904. Accessories and instrumentation**

Compressors and pumps are to be fitted with accessories and instrumentation necessary for efficient and reliable function. ↓

## CHAPTER 10 POWER GENERATION INCLUDING PROPULSION AND OTHER GAS CONSUMER

### Section 1 Goal

#### 101. Goal

The goal of this Chapter is to provide safe and reliable delivery of mechanical, electrical or thermal energy.

### Section 2 Function Requirements

#### 201. Function requirements [See Guidance]

This Chapter is related to functional requirements in Ch 2, 201. 1, 11, 13, 16 and 17. In particular the following apply:

1. The exhaust systems are to be configured to prevent any accumulation of un-burnt gaseous fuel;
2. unless designed with the strength to withstand the worst case over pressure due to ignited gas leaks, engine components or systems containing or likely to contain an ignitable gas and air mixture are to be fitted with suitable pressure relief systems. Dependent on the particular engine design this may include the air inlet manifolds and scavenge spaces; [See Guidance]
3. the explosion venting is to be led away from where personnel may normally be present; and
4. all gas consumers are to have a separate exhaust system.

### Section 3 Internal Combustion Engines of Piston Type

#### 301. General

1. The exhaust system is to be equipped with explosion relief ventilation sufficiently dimensioned to prevent excessive explosion pressures in the event of ignition failure of one cylinder followed by ignition of the unburned gas in the system.
2. For engines where the space below the piston is in direct communication with the crankcase a detailed evaluation regarding the hazard potential of fuel gas accumulation in the crankcase is to be carried out and reflected in the safety concept of the engine.
3. Each engine other than two-stroke crosshead diesel engines is to be fitted with vent systems independent of other engines for crankcases and sumps.
4. Where gas can leak directly into the auxiliary system medium (lubricating oil, cooling water), an appropriate means is to be fitted after the engine outlet to extract gas in order to prevent gas dispersion. The gas extracted from auxiliary systems media is to be vented to a safe location in the atmosphere.
5. For engines fitted with ignition systems, prior to admission of gas fuel, correct operation of the ignition system on each unit is to be verified.
6. A means is to be provided to monitor and detect poor combustion or misfiring. In the event that it is detected, gas operation may be allowed provided that the gas supply to the concerned cylinder is shut off and provided that the operation of the engine with one cylinder cut-off is acceptable with respects to torsional vibrations. [See Guidance]
7. For engines starting on fuels covered by this Rules, if combustion has not been detected by the engine monitoring system within an engine specific time after the opening of the fuel supply valve, the fuel supply valve is to be automatically shut off. Means to ensure that any unburnt fuel mixture is purged away from the exhaust system are to be provided.

8. Ignition mediums and main fuel of engines specified in 302., 303. and 304. are given in Table 10.1

**Table 10.1 Ignition medium of engine**

	Gas only		Dual Fuel	Multi Fuel
Ignition medium	Spark	Pilot fuel	Pilot fuel	N/A
Main fuel	Gas	Gas	Gas and/or oil fuel	Gas and/or liquid

### 302. Dual fuel engines

1. In case of shutoff of the gas fuel supply, the engines are to be capable of continuous operation by oil fuel only without interruption.
2. An automatic system is to be fitted to change over from gas fuel operation to oil fuel operation and vice versa with minimum fluctuation of the engine power. Acceptable reliability is to be demonstrated through testing. In the case of unstable operation on engines when gas firing, the engine is automatically to change to oil fuel mode. Manual activation of gas system shutdown is always to be possible.
3. In case of a normal stop or an emergency shutdown, the gas fuel supply is to be shut off not later than the ignition source. It is not to be possible to shut off the ignition source without first or simultaneously closing the gas supply to each cylinder or to the complete engine.

### 303. Gas-only engines

In case of a normal stop or an emergency shutdown, the gas fuel supply is to be shut off not later than the ignition source. It is not to be possible to shut off the ignition source without first or simultaneously closing the gas supply to each cylinder or to the complete engine.

### 304. Multi-fuel engines

1. In case of shutoff of one fuel supply, the engines are to be capable of continuous operation by an alternative fuel with minimum fluctuation of the engine power.
2. An automatic system is to be fitted to change over from one fuel operation to an alternative fuel operation with minimum fluctuation of the engine power. Acceptable reliability is to be demonstrated through testing. In the case of unstable operation on an engine when using a particular fuel, the engine is automatically to change to an alternative fuel mode. Manual activation is always to be possible.

## Section 4 Main and Auxiliary Boilers, Gas Turbine

### 401. Main and auxiliary boilers

1. Each boiler is to have a dedicated forced draught system. A crossover between boiler force draught systems may be fitted for emergency use providing that any relevant safety functions are maintained.
2. Combustion chambers and uptakes of boilers are to be designed to prevent any accumulation of gaseous fuel.
3. Burners are to be designed to maintain stable combustion under all firing conditions.
4. On main/propulsion boilers an automatic system are to be provided to change from gas fuel operation to oil fuel operation without interruption of boiler firing.
5. Gas nozzles and the burner control system are to be configured such that gas fuel can only be ig-

nited by an established oil fuel flame, unless the boiler and combustion equipment is designed and approved by the Society to light on gas fuel.

6. There are to be arrangements to ensure that gas fuel flow to the burner is automatically cut off unless satisfactory ignition has been established and maintained.
7. On the fuel pipe of each gas burner a manually operated shutoff valve is to be fitted.
8. Provisions are to be made for automatically purging the gas supply piping to the burners, by means of an inert gas, after the extinguishing of these burners.
9. The automatic fuel changeover system required by 4 is to be monitored with alarms to ensure continuous availability.
10. Arrangements are to be made that, in case of flame failure of all operating burners, the combustion chambers of the boilers are automatically purged before relighting.
11. Arrangements are to be made to enable the boilers purging sequence to be manually activated.

## Section 5 Gas Turbines

### 501. Gas turbines

1. Unless designed with the strength to withstand the worst case over pressure due to ignited gas leaks, pressure relief systems are to be suitably designed and fitted to the exhaust system, taking into consideration of explosions due to gas leaks. Pressure relief systems within the exhaust uptakes are to be lead to a safe location, away from personnel.
2. The gas turbine may be fitted in a gas-tight enclosure arranged in accordance with the ESD principle outlined in **Ch 5, 601.** and **Ch 9, 701.**, however a pressure above 1.0 MPa in the gas supply piping may be accepted within this enclosure.
3. Gas detection systems and shutdown functions are to be as outlined for ESD protected machinery spaces.
4. Ventilation for the enclosure is to be as outlined in **Ch 13** for ESD protected machinery spaces, but is in addition to be arranged with full redundancy (2 x 100 % capacity fans from different electrical circuits).
5. For other than single fuel gas turbines, an automatic system is to be fitted to change over easily and quickly from gas fuel operation to oil fuel operation and vice-versa with minimum fluctuation of the engine power.
6. Means are to be provided to monitor and detect poor combustion that may lead to unburnt fuel gas in the exhaust system during operation. In the event that it is detected, the fuel gas supply is to be shutdown.
7. Each turbine is to be fitted with an automatic shutdown device for high exhaust temperatures. ↓

## CHAPTER 11 FIRE SAFETY

### Section 1 Goal

#### 101. Goal

The goal of this Chapter is to provide for fire protection, detection and fighting for all system components related to the storage, conditioning, transfer and use of natural gas as ship fuel.

### Section 2 Functional Requirements

#### 201. Functional requirements

This Chapter is related to functional requirements in **Ch 2, 201. 2, 4, 5, 7, 12, 14, 15 and 17.**

### Section 3 Fire Protection

#### 301. Fire protection

1. Any space containing equipment for the fuel preparation such as pumps, compressors, heat exchangers, vaporizers and pressure vessels is to be regarded as a machinery space of category A for fire protection purposes. **[See Guidance]**
2. Any boundary of accommodation spaces, service spaces, control stations, escape routes and machinery spaces, facing fuel tanks on open deck, is to be shielded by A-60 class divisions. The A-60 class divisions are to extend up to the underside of the deck of the navigation bridge. In addition, fuel tanks are to be segregated from cargo in accordance with the requirements of the **IMDG Code** where the fuel tanks are regarded as bulk packaging. For the purposes of the stowage and segregation requirements of the **IMDG Code**, a fuel tank on the open deck is to be considered a class 2.1 package.
3. The space containing fuel containment system is to be separated from the machinery spaces of category A or other rooms with high fire risks. The separation is to be done by a cofferdam of at least 900 mm with insulation of A-60 class. When determining the insulation of the space containing fuel containment system from other spaces with lower fire risks, the fuel containment system is to be considered as a machinery space of category A, in accordance with **SOLAS regulation II-2/9**. The boundary between spaces containing fuel containment systems is to be either a cofferdam of at least 900 mm or A-60 class division. For type C tanks, the fuel storage hold space may be considered as a cofferdam. **[See Guidance]**
4. The fuel storage hold space is not to be used for machinery or equipment that may have a fire risk.
5. The fire protection of fuel pipes led through ro-ro spaces is to be subject to special consideration by the Society depending on the use and expected pressure in the pipes.
6. The bunkering station is to be separated by A-60 class divisions towards machinery spaces of category A, accommodation, control stations and high fire risk spaces, except for spaces such as tanks, voids, auxiliary machinery spaces of little or no fire risk, sanitary and similar spaces where the insulation standard may be reduced to class A-0.
7. If an ESD protected machinery spaces is separated by a single boundary, the boundary is to be of A-60 class division.

### Section 4 Fire main

#### 401. Fire main

1. The water spray system required below may be part of the fire main system provided that the required fire pump capacity and working pressure are sufficient for the operation of both the required

numbers of hydrants and hoses and the water spray system simultaneously.

2. When the fuel storage tank is located on the open deck, isolating valves are to be fitted in the fire main in order to isolate damaged sections of the fire main. Isolation of a section of fire main is not to deprive the fire line ahead of the isolated section from the supply of water.

## Section 5 Water spray systems

### 501. Water spray systems

1. A water spray system is to be installed for cooling and fire prevention to cover exposed parts of fuel storage tank located on open deck.
2. The water spray system is also to provide coverage for boundaries of the superstructures, compressor rooms, pump-rooms, cargo control rooms, bunkering control stations, bunkering stations and any other normally occupied deck houses that face the storage tank on open decks unless the tank is located 10 m or more from the boundaries.
3. The system is to be designed to cover all areas as specified above with an application rate of 10 l/min/m<sup>2</sup> for the largest horizontal projected surfaces and 4 l/min/m<sup>2</sup> for vertical surfaces.
4. Stop valves are to be fitted in the water spray application main supply line, at intervals not exceeding 40 m, for the purpose of isolating damaged sections. Alternatively, the system may be divided into two or more sections that may be operated independently, provided the necessary controls are located together in a readily accessible position not likely to be inaccessible in case of fire in the areas protected.
5. The capacity of the water spray pump is to be sufficient to deliver the required amount of water to the hydraulically most demanding area as specified above in the areas protected.
6. If the water spray system is not part of the fire main system, a connection to the ship's fire main through a stop valve is to be provided.
7. Remote start of pumps supplying the water spray system and remote operation of any normally closed valves to the system are to be located in a readily accessible position which is not likely to be inaccessible in case of fire in the areas protected.
8. The nozzles are to be of an approved full bore type and they are to be arranged to ensure an effective distribution of water throughout the space being protected.

## Section 6 Dry chemical powder fire-extinguishing system

### 601. Dry chemical powder fire-extinguishing system

1. A permanently installed dry chemical powder fire-extinguishing system is to be installed in the bunkering station area to cover all possible leak points. The capacity is to be at least 3.5 kg/s for a minimum of 45 s. The system is to be arranged for easy manual release from a safe location outside the protected area.
2. In addition to any other portable fire extinguishers that may be required elsewhere in IMO instruments, one portable dry powder extinguisher of at least 5 kg capacity is to be located near the bunkering station.

## Section 7 Fire detection and alarm system

### 701. Fire detection and alarm system

1. A fixed fire detection and fire alarm system complying with the **FSS Code** is to be provided for the fuel storage hold spaces and the ventilation trunk for fuel containment system below deck, and for all other rooms of the fuel gas system where fire cannot be excluded.
2. Smoke detectors alone are not to be considered sufficient for rapid detection of a fire.⚠

## CHAPTER 12 EXPLOSION PREVENTION

### Section 1 Goal

#### 101. Goal

The goal of this Chapter is to provide for the prevention of explosions and for the limitation of effects from explosion.

### Section 2 Functional Requirements

#### 201. Functional requirements

This Chapter is related to functional requirements in **Ch 2, 201. 2, 3, 4, 5, 7, 8, 12, 13, 14** and **17**. In particular the following apply:

1. The probability of explosions is to be reduced to a minimum by:
  - (1) reducing number of sources of ignition; and
  - (2) reducing the probability of formation of ignitable mixtures.

### Section 3 General Requirements

#### 301. General requirements

1. Hazardous areas on open deck and other spaces not defined in this Section are to be decided based on a recognized standard. The electrical equipment fitted within hazardous areas is to be according to the same standard. **[See Guidance]**
2. Electrical equipment and wiring are in general not to be installed in hazardous areas unless essential for operational purposes based on a recognized standard. **[See Guidance]**
3. Electrical equipment fitted in an ESD-protected machinery space is to fulfil the following:
  - (1) in addition to fire and gas hydrocarbon detectors and fire and gas alarms, lighting and ventilation fans are to be certified safe for hazardous area zone 1; and
  - (2) all electrical equipment in a machinery space containing gas-fuelled engines, and not certified for zone 1 is to be automatically disconnected, if gas concentrations above 40 % LEL is detected by two detectors in the space containing gas-fuelled consumers.

### Section 4 Area classification

#### 401. Area classification

1. Area classification is a method of analysing and classifying the areas where explosive gas atmospheres may occur. The object of the classification is to allow the of electrical apparatus able to be operated safely in these areas.
2. In order to facilitate the selection of appropriate electrical apparatus and the design of suitable electrical installations, hazardous areas are divided into zones 0, 1 and 2 and the area classification is to be in accordance with **402.. [See Guidance]**
3. Ventilation ducts are to have the same area classification as the ventilated space.

## Section 5 Hazardous Area Zones

### 501. Zone “0”

Zone "0" includes, but is not limited to:

1. The interiors of fuel tanks
2. Pipes and equipment containing fuel
3. Any pipe work of pressure-relief or other venting systems for fuel tanks

### 502. Zone “1” [See Guidance]

This zone includes, but is not limited to:

1. tank connection spaces, fuel storage hold spaces (Fuel storage hold spaces for type C tanks are normally not considered as zone “1”) and interbarrier spaces;
2. fuel preparation room arranged with ventilation according to **Ch 13, 601.**;
3. areas on open deck, or semi-enclosed spaces on deck, within 3 m of any fuel tank outlet, gas or vapour outlet, bunker manifold valve, other fuel valve, fuel pipe flange, fuel preparation room ventilation outlets and fuel tank openings for pressure release provided to permit the flow of small volumes of gas or vapour mixtures caused by thermal variation;
4. areas on open deck or semi-enclosed spaces on deck, within 1.5 m of fuel preparation room entrances, fuel preparation room ventilation inlets and other openings into zone “1” spaces;
5. areas on the open deck within spillage coamings surrounding gas bunker manifold valves and 3 m beyond these, up to a height of 2.4 m above the deck;
6. enclosed or semi-enclosed spaces in which pipes containing fuel are located, e.g. ducts around fuel pipes, semi-enclosed bunkering stations;
7. the ESD-protected machinery space is considered a non-hazardous area during normal operation, but will require equipment required to operate following detection of gas leakage to be certified as suitable for zone “1”;
8. a space protected by an airlock is considered as non-hazardous area during normal operation, but will require equipment required to operate following loss of differential pressure between the protected space and the hazardous area to be certified as suitable for zone “1”; and
9. except for type C tanks, an area within 2.4 m of the outer surface of a fuel containment system where such surface is exposed to the weather.

### 503. Zone “2” [See Guidance]

This zone includes, but is not limited to:

1. areas within 1.5 m surrounding open or semi-enclosed spaces of zone “1”; and
2. space containing bolted hatch to tank connection space.↓

## CHAPTER 13 VENTILATION

### Section 1 Goal

#### 101. Goal

The goal of this Chapter is to provide for the ventilation required for safe operation of gas-fuelled machinery and equipment.

### Section 2 Functional Requirements

#### 201. Functional requirements

This Chapter is related to functional requirements in Ch 2, 201. 2, 5, 8, 10, 12, 13, 14 and 17.

### Section 3 General Requirements

#### 301. Ventilation of hazardous spaces

Any ducting used for the ventilation of hazardous spaces is to be separate from that used for the ventilation of non-hazardous spaces. The ventilation is to function at all temperatures and environmental conditions the ship will be operating in.

#### 302. Electric motors for ventilation fans

Electric motors for ventilation fans are not to be located in ventilation ducts for hazardous spaces unless the motors are certified for the same hazard zone as the space served.

#### 303. Design of ventilation fans serving spaces containing gas sources [See Guidance]

Design of ventilation fans serving spaces containing gas sources is to fulfil the following:

1. Ventilation fans are not to produce a source of vapour ignition in either the ventilated space or the ventilation system associated with the space. Ventilation fans and fan ducts, in way of fans only, are to be of non-sparking construction defined as:
  - (1) impellers or housings of non-metallic material, due regard being paid to the elimination of static electricity;
  - (2) impellers and housings of non-ferrous metals;
  - (3) impellers and housings of austenitic stainless steel;
  - (4) impellers of aluminium alloys or magnesium alloys and a ferrous (including austenitic stainless steel) housing on which a ring of suitable thickness of non-ferrous materials is fitted in way of the impeller, due regard being paid to static electricity and corrosion between ring and housing; or.
  - (5) any combination of ferrous (including austenitic stainless steel) impellers and housings with not less than 13 mm tip design clearance.
2. In no case is the radial air gap between the impeller and the casing to be less than 0.1 of the diameter of the impeller shaft in way of the bearing but not less than 2 mm. The gap need not be more than 13 mm.
3. Any combination of an aluminium or magnesium alloy fixed or rotating component and a ferrous fixed or rotating component, regardless of tip clearance, is considered a sparking hazard and is not to be used in these places.

#### 304. Separation of ventilation systems

Ventilation systems required to avoid any gas accumulation are to consist of independent fans, each of sufficient capacity, unless otherwise specified in this Rules.

**305. Air inlets for hazardous enclosed spaces**

Air inlets for hazardous enclosed spaces are to be taken from areas that, in the absence of the considered inlet, would be non-hazardous. Air inlets for non-hazardous enclosed spaces are to be taken from non-hazardous areas at least 1.5 m away from the boundaries of any hazardous area. Where the inlet duct passes through a more hazardous space, the duct is to be gas-tight and have over-pressure relative to this space.

**306. Air outlets from non-hazardous spaces**

Air outlets from non-hazardous spaces are to be located outside hazardous areas.

**307. Air outlets from hazardous enclosed spaces**

Air outlets from hazardous enclosed spaces are to be located in an open area that, in the absence of the considered outlet, would be of the same or lesser hazard than the ventilated space.

**308. Required capacity of the ventilation plant**

The required capacity of the ventilation plant is normally based on the total volume of the room. An increase in required ventilation capacity may be necessary for rooms having a complicated form.

**309. Non-hazardous spaces with entry openings to a hazardous area**

Non-hazardous spaces with entry openings to a hazardous area are to be arranged with an airlock and be maintained at overpressure relative to the external hazardous area. The overpressure ventilation is to be arranged according to the following:

1. During initial start-up or after loss of overpressure ventilation, before energizing any electrical installations not certified safe for the space in the absence of pressurization, it is to be required to:
  - (1) proceed with purging (at least 5 air changes) or confirm by measurements that the space is non-hazardous; and
  - (2) pressurize the space.
2. Operation of the overpressure ventilation is to be monitored and in the event of failure of the overpressure ventilation:
  - (1) an audible and visual alarm is to be given at a manned location; and
  - (2) if overpressure cannot be immediately restored, automatic or programmed disconnection of electrical installations according to a recognized standard is to be required. **[See Guidance]**

**310. Non-hazardous spaces with entry openings to a hazardous enclosed space**

Non-hazardous spaces with entry openings to a hazardous enclosed space are to be arranged with an airlock and the hazardous space is to be maintained at underpressure relative to the non-hazardous space. Operation of the extraction ventilation in the hazardous space is to be monitored and in the event of failure of the extraction ventilation:

1. an audible and visual alarm is to be given at a manned location; and
2. if underpressure cannot be immediately restored, automatic or programmed, disconnection of electrical installations according to a recognized standard in the non-hazardous space is to be required. **[See Guidance]**

## Section 4 Tank Connection Space

**401. Tank connection space**

1. The tank connection space is to be provided with an effective mechanical forced ventilation system of extraction type. A ventilation capacity of at least 30 air changes per hour is to be provided. The rate of air changes may be reduced if other adequate means of explosion protection are installed. The equivalence of alternative installations is to be demonstrated by a risk assessment.

2. Approved automatic fail-safe fire dampers are to be fitted in the ventilation trunk for the tank connection space.

## Section 5 Machinery Spaces

### 501. Machinery Spaces

1. The ventilation system for machinery spaces containing gas-fuelled consumers is to be independent of all other ventilation systems. **[See Guidance]**
2. ESD protected machinery spaces are to have ventilation with a capacity of at least 30 air changes per hour. The ventilation system is to ensure a good air circulation in all spaces, and in particular ensure that any formation of gas pockets in the room are detected. As an alternative, arrangements whereby under normal operation the machinery spaces are ventilated with at least 15 air changes an hour is acceptable provided that, if gas is detected in the machinery space, the number of air changes will automatically be increased to 30 an hour.
3. For ESD protected machinery spaces the ventilation arrangements are to provide sufficient redundancy to ensure a high level of ventilation availability as defined in a recognized standard by the Society. **[See Guidance]**
4. The number and power of the ventilation fans for ESD protected engine-rooms and for double pipe ventilation systems for gas safe engine-rooms are to be such that the capacity is not reduced by more than 50 % of the total ventilation capacity if a fan with a separate circuit from the main switchboard or emergency switchboard or a group of fans with common circuit from the main switchboard or emergency switchboard, is inoperable.

## Section 6 Fuel Preparation Room

### 601. Fuel preparation room

1. Fuel preparation rooms are to be fitted with effective mechanical ventilation system of the under-pressure type, providing a ventilation capacity of at least 30 air changes per hour.
2. The number and power of the ventilation fans are to be such that the capacity is not reduced by more than 50 %, if a fan with a separate circuit from the main switchboard or emergency switchboard or a group of fans with common circuit from the main switchboard or emergency switchboard, is inoperable.
3. Ventilation systems for fuel preparation rooms, are to be in operation when pumps or compressors are working.

## Section 7 Bunkering station

### 701. Bunkering station

Bunkering stations that are not located on open deck are to be suitably ventilated to ensure that any vapour being released during bunkering operations will be removed outside. If the natural ventilation is not sufficient, mechanical ventilation is to be provided in accordance with the risk assessment required by **Ch 8, 301. 1**.

## Section 8 Ducts and Double Pipes

### 801. Ducts and double pipes

1. Ducts and double pipes containing fuel piping are to be fitted with effective mechanical ventilation

system of the extraction type, providing a ventilation capacity of at least 30 air changes per hour. This is not applicable to double pipes in the engine-room if fulfilling **Ch 9, 601. 1.**

2. The ventilation system for double piping and for gas valve unit spaces in gas safe engine-rooms is to be independent of all other ventilation systems. **[See Guidance]**
3. The ventilation inlet for the double wall piping or duct is always to be located in a non-hazardous area away from ignition sources. The inlet opening is to be fitted with a suitable wire mesh guard and protected from ingress of water. **[See Guidance]**
4. The capacity of the ventilation for a pipe duct or double wall piping may be below 30 air changes per hour if a flow velocity of minimum 3 m/s is ensured. The flow velocity is to be calculated for the duct with fuel pipes and other components installed. ⤵

# CHAPTER 14 ELECTRICAL INSTALLATIONS

## Section 1 Goal

### 101. Goal

The goal of this Chapter is to provide for electrical installations that minimizes the risk of ignition in the presence of a flammable atmosphere.

## Section 2 Functional Requirements

### 201. Functional requirements

This Chapter is related to functional requirements in **Ch 2, 201. 1, 2, 4, 7, 8, 11, 13 and 16**, to **18**. In particular the following apply:

Electrical generation and distribution systems, and associated control systems, are to be designed such that a single fault will not result in the loss of ability to maintain fuel tank pressures and hull structure temperature within normal operating limits.

## Section 3 General Requirements

### 301. General requirements

1. Electrical installations are to be in compliance with a standard at least equivalent to those acceptable to the Society.
2. Electrical equipment or wiring is to not be installed in hazardous areas unless essential for operational purposes or safety enhancement.
3. Where electrical equipment is installed in hazardous areas as provided in **2**, it is to be selected, installed and maintained in accordance with standards at least equivalent to those acceptable to the Society. Equipment for hazardous areas is to be of a certified safe type.
4. Failure modes and effects of single failure for electrical generation and distribution systems in **201**, are to be analysed and documented to be at least equivalent to those acceptable to the Society.  
[See Guidance]
5. The lighting system in hazardous areas is to be divided between at least two branch circuits. All switches and protective devices are to interrupt all poles or phases and are to be located in a non-hazardous area.
6. The installation on board of the electrical equipment units is to be such as to ensure the safe bonding to the hull of the units themselves.
7. Arrangements are to be made to alarm in low-liquid level and automatically shutdown the motors of fuel pumps in the event of low-liquid level. The automatic shutdown may be accomplished by sensing low pump discharge pressure, low motor current, or low-liquid level. This shutdown is to give an audible and visual alarm on the navigation bridge, continuously manned central control station or onboard safety centre.
8. Submerged fuel pump motors and their supply cables may be fitted in liquefied gas fuel containment systems. Fuel pump motors are to be capable of being isolated from their electrical supply during gas-freeing operations.
9. For non-hazardous spaces with access from hazardous open deck where the access is protected by an airlock, electrical equipment which is not of the certified safe type is to be de-energized upon loss of overpressure in the space.
10. Electrical equipment for propulsion, power generation, manoeuvring, anchoring and mooring, as well as emergency fire pumps, that are located in spaces protected by airlocks, is to be of a certified safe type.↓

# CHAPTER 15 CONTROL, MONITORING AND SAFETY SYSTEMS

## Section 1 Goal

### 101. Goal

The goal of this Chapter is to provide for the arrangement of control, monitoring and safety systems that support an efficient and safe operation of the gas-fuelled installation as covered in the other chapters of this Rules.

## Section 2 Functional Requirements

### 201. Functional requirements

This Chapter is related to functional requirements in **Ch 2, 201. 1, 2, 11, 13 to 15, 17 and 18**. In particular the following apply:

1. the control, monitoring and safety systems of the gas-fuelled installation are to be so arranged that the remaining power for propulsion and power generation is in accordance with **Ch 9, 301**. in the event of single failure;
2. a gas safety system is to be arranged to close down the gas supply system automatically, upon failure in systems as described in **Table 15.1** and upon other fault conditions which may develop too fast for manual intervention;
3. for ESD protected machinery configurations the safety system is to shutdown gas supply upon gas leakage and in addition disconnect all non-certified safe type electrical equipment in the machinery space;
4. the safety functions are to be arranged in a dedicated gas safety system that is independent of the gas control system in order to avoid possible common cause failures. This includes power supplies and input and output signal;
5. the safety systems including the field instrumentation are to be arranged to avoid spurious shutdown, e.g. as a result of a faulty gas detector or a wire break in a sensor loop; and
6. where two or more gas supply systems are required to meet the regulations, each system is to be fitted with its own set of independent gas control and gas safety systems.

## Section 3 General Requirements

### 301. General requirements

1. Suitable instrumentation devices are to be fitted to allow a local and a remote reading of essential parameters to ensure a safe management of the whole fuel-gas equipment including bunkering.
2. A bilge well in each tank connection space of an independent liquefied gas storage tank is to be provided with both a level indicator and a temperature sensor. Alarm is to be given at high level in the bilge well. Low temperature indication is to activate the safety system. **[See Guidance]**
3. For tanks not permanently installed in the ship a monitoring system is to be provided as for permanently installed tanks.

## Section 4 Bunkering and Liquefied Gas Fuel Tank Monitoring

### 401. Level indicators for liquefied gas fuel tanks

1. Each liquefied gas fuel tank is to be fitted with liquid level gauging device, arranged to ensure a level reading is always obtainable whenever the liquefied gas fuel tank is operational. The device is to be designed to operate throughout the design pressure range of the liquefied gas fuel tank and at temperatures within the fuel operating temperature range.
2. Where only one liquid level gauge is fitted it is to be arranged so that it can be maintained in an operational condition without the need to empty or gas-free the tank.
3. Liquefied gas fuel tank liquid level gauges may be of the following types:
  - (1) indirect devices, which determine the amount of fuel by means such as weighing or in-line flow metering; or
  - (2) closed devices, which do not penetrate the liquefied gas fuel tank, such as devices using radio-isotopes or ultrasonic devices;

### 402. Overflow control

1. Each liquefied gas fuel tank is to be fitted with a high liquid level alarm operating independently of other liquid level indicators and giving an audible and visual warning when activated.
2. An additional sensor operating independently of the high liquid level alarm is automatically to actuate a shutoff valve in a manner that will both avoid excessive liquid pressure in the bunkering line and prevent the liquefied gas fuel tank from becoming liquid full.
3. The position of the sensors in the liquefied gas fuel tank is to be capable of being verified before commissioning. At the first occasion of full loading after delivery and after each dry-docking, testing of high level alarms is to be conducted by raising the fuel liquid level in the liquefied gas fuel tank to the alarm point. **[See Guidance]**
4. All elements of the level alarms, including the electrical circuit and the sensor, of the high, and overflow alarms, are to be capable of being functionally tested. Systems are to be tested prior to fuel operation in accordance with **18.4.3** of **IGF Code**.
5. Where arrangements are provided for overriding the overflow control system, they are to be such that inadvertent operation is prevented. When this override is operated continuous visual indication is to be provided at the navigation bridge, continuously manned central control station or onboard safety centre.

### 403. Pressure monitoring

1. The vapour space of each liquefied gas fuel tank is to be provided with a direct reading gauge. Additionally, an indirect indication is to be provided on the navigation bridge, continuously manned central control station or onboard safety centre.
2. The pressure indicators are to be clearly marked with the highest and lowest pressure permitted in the liquefied gas fuel tank.
3. A high-pressure alarm and, if vacuum protection is required, a low-pressure alarm are to be provided on the navigation bridge and at a continuously manned central control station or onboard safety centre. Alarms are to be activated before the set pressures of the safety valves are reached.
4. Each fuel pump discharge line and each liquid and vapour fuel manifold are to be provided with at least one local pressure indicator.
5. Local-reading manifold pressure indicator is to be provided to indicate the pressure between ship's manifold valves and hose connections to the shore.
6. Fuel storage hold spaces and interbarrier spaces without open connection to the atmosphere are to be provided with pressure indicator.
7. At least one of the pressure indicators provided are to be capable of indicating throughout the operating pressure range.

8. For submerged fuel-pump motors and their supply cables, arrangements are to be made to alarm in low-liquid level and automatically shutdown the motors in the event of low-liquid level. The automatic shutdown may be accomplished by sensing low pump discharge pressure, low motor current, or low-liquid level. This shutdown is to give an audible and visual alarm on the navigation bridge, continuously manned central control station or onboard safety centre.
9. Except for independent tanks of type C supplied with vacuum insulation system and pressure build-up fuel discharge unit, each fuel tank is to be provided with devices to measure and indicate the temperature of the fuel in at least three locations; at the bottom and middle of the tank as well as the top of the tank below the highest allowable liquid level.

## Section 5 Bunkering Control

### 501. Bunkering control

1. Control of the bunkering is to be possible from a safe location remote from the bunkering station. At this location the tank pressure, tank temperature if required by **401. 9**, and tank level is to be monitored. Remotely controlled valves required by **Ch 8, 501. 3** and **Ch 11, 501. 7** are to be capable of being operated from this location. Overfill alarm and automatic shutdown are also to be indicated at this location.
2. If the ventilation in the ducting enclosing the bunkering lines stops, an audible and visual alarm is to be provided at the bunkering control location, see also **801..**
3. If gas is detected in the ducting around the bunkering lines an audible and visual alarm and emergency shutdown are to be provided at the bunkering control location.

## Section 6 Gas Compressor Monitoring

### 601. Gas compressor monitoring

1. Gas compressors are to be fitted with audible and visual alarms both on the navigation bridge and in the engine control room. As a minimum the alarms are to include low gas input pressure, low gas output pressure, high gas output pressure and compressor operation.
2. Temperature monitoring for the bulkhead shaft glands and bearings is to be provided, which automatically give a continuous audible and visual alarm on the navigation bridge or in a continuously manned central control station.

## Section 7 Gas Engine Monitoring

### 701. Gas engine monitoring

In addition to the instrumentation provided in accordance with **Pt 5 of Rules for the classification of steel ships**, indicators are to be fitted on the navigation bridge, the engine control room and the maneuvering platform for:

1. operation of the engine in case of gas-only engines; or
2. operation and mode of operation of the engine in the case of dual fuel engines.

## Section 8 Gas Detection

### 801. Gas detection

1. Permanently installed gas detectors are to be fitted in:
  - (1) the tank connection spaces;
  - (2) all ducts around fuel pipes;
  - (3) machinery spaces containing gas piping, gas equipment or gas consumers;
  - (4) compressor rooms and fuel preparation rooms;
  - (5) other enclosed spaces containing fuel piping or other fuel equipment without ducting;
  - (6) other enclosed or semi-enclosed spaces where fuel vapours may accumulate including interbarrier spaces and fuel storage hold spaces of independent tanks other than type C;
  - (7) airlocks;
  - (8) gas heating circuit expansion tanks;
  - (9) motor rooms associated with the fuel systems; and
  - (10) at ventilation inlets to accommodation and machinery spaces if required based on the risk assessment required in **Ch 4, 201..**
2. In each ESD-protected machinery space, redundant gas detection systems are to be provided.
3. The number of detectors in each space are to be considered taking into account the size, layout and ventilation of the space.
4. The detection equipment is to be located where gas may accumulate and in the ventilation outlets. Gas dispersal analysis or a physical smoke test is to be used to find the best arrangement.
5. Gas detection equipment is to be designed, installed and tested in accordance with **IEC 60079-29-1. [See Guidance]**
6. An audible and visible alarm is to be activated at a gas vapour concentration of 20 % of the lower explosion limit (LEL). The safety system is to be activated at 40 % of LEL at two detectors (see **Note 1**) in **Table 15.1**).
7. For ventilated ducts around gas pipes in the machinery spaces containing gas-fuelled engines, the alarm limit can be set to 30 % LEL. The safety system is to be activated at 60 % of LEL at two detectors (see **Note 1**) in **Table 15.1**).
8. Audible and visible alarms from the gas detection equipment are to be located on the navigation bridge or in the continuously manned central control station.
9. Gas detection required by this Section is to be continuous without delay.

## Section 9 Fire Detection

### 901. Fire detection

Required safety actions at fire detection in the machinery space containing gas-fuelled engines and rooms containing independent tanks for fuel storage hold spaces are given in **Table 15.1** below.

Table 15.1 Monitoring of gas supply system to engines

Parameter	Alarm	Automatic shutdown of main tank valve	Automatic shutdown of gas supply to machinery space containing gas-fuelled engines	Remarks
Gas detection in tank connection space at 20 % LEL	X			
Gas detection on two detectors <sup>1)</sup> tank connection space at 40 % LEL	X	X		
Fire detection in fuel storage hold space	X			
Fire detection in ventilation trunk for fuel containment system below deck	X			
Bilge well high level in tank connection space	X			
Bilge well low temperature in tank connection space	X	X		
Gas detection in duct between tank and machinery space containing gas-fuelled engines at 20 % LEL	X			
Gas detection on two detectors <sup>1)</sup> in duct between tank and machinery space containing gas-fuelled engines at 40 % LEL	X	X <sup>2)</sup>		
Gas detection in fuel preparation room at 20 % LEL	X			
Gas detection on two detectors <sup>1)</sup> in fuel preparation room at 40 % LEL	X	X <sup>2)</sup>		
Gas detection in duct inside machinery space containing gas-fuelled engines at 30 % LEL	X			If double pipe fitted in machinery space containing gas-fuelled engines
Gas detection on two detectors <sup>1)</sup> in duct inside machinery space containing gas-fuelled engines at 60 % LEL	X		X <sup>3)</sup>	If double pipe fitted in machinery space containing gas-fuelled engines
Gas detection in ESD protected machinery space containing gasfuelled engines at 20 % LEL	X			Gas detection only required for ESD protected machinery space

Table 15.1 Monitoring of gas supply system to engines (continued)

Parameter	Alarm	Automatic shutdown of main tank valve	Automatic shutdown of gas supply to machinery space containing gas-fuelled engines	Remarks
Gas detection on two detectors <sup>1)</sup> in ESD protected machinery space containing gas-fuelled engines at 40 % LEL	X		X	It is also to disconnect non certified safe electrical equipment in machinery space containing gas-fuelled engines
Loss of ventilation in duct between tank and machinery space containing gas-fuelled engines	X		X <sup>2)</sup>	
Loss of ventilation in duct inside machinery space containing gas-fuelled engines <sup>5)</sup>	X		X <sup>3)</sup>	If double pipe fitted in machinery space containing gas-fuelled engines
Loss of ventilation in ESD protected machinery space containing gas-fuelled engines	X		X	
Fire detection in machinery space containing gas-fuelled engines	X			
Abnormal gas pressure in gas supply pipe	X			
Failure of valve control actuating medium	X		X <sup>4)</sup>	Time delayed as found necessary
Automatic shutdown of engine (engine failure)	X		X <sup>4)</sup>	
Manually activated emergency shutdown of engine	X		X	
<p>Note :</p> <ol style="list-style-type: none"> <li>1) Two independent gas detectors located close to each other are required for redundancy reasons. If the gas detector is of self monitoring type the installation of a single gas detector can be permitted.</li> <li>2) If the tank is supplying gas to more than one engine and the different supply pipes are completely separated and fitted in separate ducts and with the master valves fitted outside of the duct, only the master valve on the supply pipe leading into the duct where gas or loss of ventilation is detected is to close.</li> <li>3) If the gas is supplied to more than one engine and the different supply pipes are completely separated and fitted in separate ducts and with the master valves fitted outside of the duct and outside of the machinery space containing gas-fuelled engines, only the master valve on the supply pipe leading into the duct where gas or loss of ventilation is detected is to close.</li> <li>4) Only double block and bleed valves to be activated.(two block valves to close and a bleed valve to open)</li> <li>5) If the duct is protected by inert gas (See <b>Ch 9, 601. 1</b>) then loss of inert gas overpressure is to lead to the same actions as given in this table.</li> <li>6) Valves referred to in <b>Ch 9, 401.</b></li> </ol>				

## Section 10 Ventilation

### 1001. Ventilation

1. Any loss of the required ventilating capacity is to give an audible and visual alarm on the navigation bridge or in a continuously manned central control station or safety centre. **[See Guidance]**
2. For ESD protected machinery spaces the safety system is to be activated upon loss of ventilation in engine room.

## Section 11 Safety Functions of Fuel Supply Systems

### 1101. Safety functions of fuel supply systems

1. If the fuel supply is shut off due to activation of an automatic valve, the fuel supply is not to be opened until the reason for the disconnection is ascertained and the necessary precautions taken. A readily visible notice giving instruction to this effect is to be placed at the operating station for the shutoff valves in the fuel supply lines.
2. If a fuel leak leading to a fuel supply shutdown occurs, the fuel supply is not to be operated until the leak has been found and dealt with. Instructions to this effect are to be placed in a prominent position in the machinery space.
3. A caution placard or signboard is to be permanently fitted in the machinery space containing gas-fuelled engines stating that heavy lifting, implying danger of damage to the fuel pipes, are not to be done when the engine is running on gas.
4. Compressors, pumps and fuel supply are to be arranged for manual remote emergency stop from the following locations as applicable:
  - (1) navigation bridge;
  - (2) cargo control room;
  - (3) onboard safety centre;
  - (4) engine control room;
  - (5) fire control station; and
  - (6) adjacent to the exit of fuel preparation rooms.

The gas compressor is to also be arranged for manual local emergency stop. ↓

# CHAPTER 16 MANUFACTURE, WORKMANSHIP AND TESTING

## Section 1 General

### 101. General

1. The manufacture, testing, inspection and documentation are to be in accordance with **Pt 2, Ch 2 of Rules for the classification of steel ships** and the regulations given in this Chapter.
2. Where post-weld heat treatment is specified or required, the properties of the base material are to be determined in the heat treated condition, in accordance with the applicable tables of **Ch 7** and the weld properties are to be determined in the heat treated condition in accordance with **Sec 3**. In cases where a post-weld heat treatment is applied, the test regulations may be modified at the discretion of this Society. **[See Guidance]**

## Section 2 General test regulations and specifications

### 201. Tensile test **[See Guidance]**

1. Tensile testing is to be carried out in accordance with **Pt 2, Ch 1, Sec 2 of Rules for the classification of steel ships**.
2. Tensile strength, yield stress and elongation are to be to the satisfaction of the Society. For carbon-manganese steel and other materials with definitive yield points, consideration is to be given to the limitation of the yield to tensile ratio.

### 202. Toughness test

1. Acceptance tests for metallic materials are to include Charpy V-notch toughness tests unless otherwise specified by the **Pt 2, Ch 1, Sec 2 of Rules for the classification of steel ships**. The specified Charpy V-notch regulations are minimum average energy values for three full size (10 mm×10 mm) specimens and minimum single energy values for individual specimens.

Dimensions and tolerances of Charpy V-notch specimens are to be in accordance with recognized standards. The testing and regulations for specimens smaller than 5.0 mm in size are to be in accordance with recognized standards. Minimum average values for sub-sized specimens are to be:

Charpy V-notch specimen size	Minimum average energy of three specimens
10 mm x 10 mm	KV
10 mm x 7.5 mm	5/6 KV
10 mm x 5.0 mm	2/3 KV

where: KV = the energy values (J) specified in **Tables 7.1 to 7.5**

Only one individual value may be below the specified average value, provided it is not less than 70% of that value. **[See Guidance]**

2. For base metal, the largest size Charpy V-notch specimens possible for the material thickness are to be machined with the specimens located as near as practicable to a point midway between the surface and the centre of the thickness and the length of the notch perpendicular to the surface as shown in **Fig 16.1**.

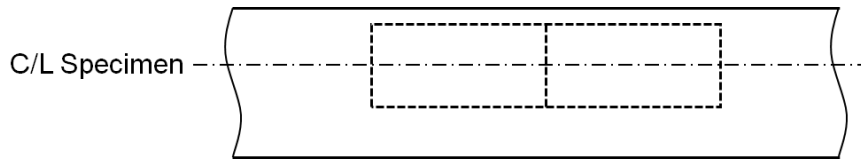

Fig 16.1 Orientation of base metal test specimen

3. For a weld test specimen, the largest size Charpy V-notch specimens possible for the material thickness are to be machined, with the specimens located as near as practicable to a point midway between the surface and the centre of the thickness. In all cases the distance from the surface of the material to the edge of the specimen is to be approximately 1 mm or greater. In addition, for double-V butt welds, specimens are to be machined closer to the surface of the second welded section. The specimens are to be taken generally at each of the following locations, as shown in **Fig 16.2**, on the centreline of the welds, the fusion line and 1 mm, 3 mm and 5 mm from the fusion line. **[See Guidance]**

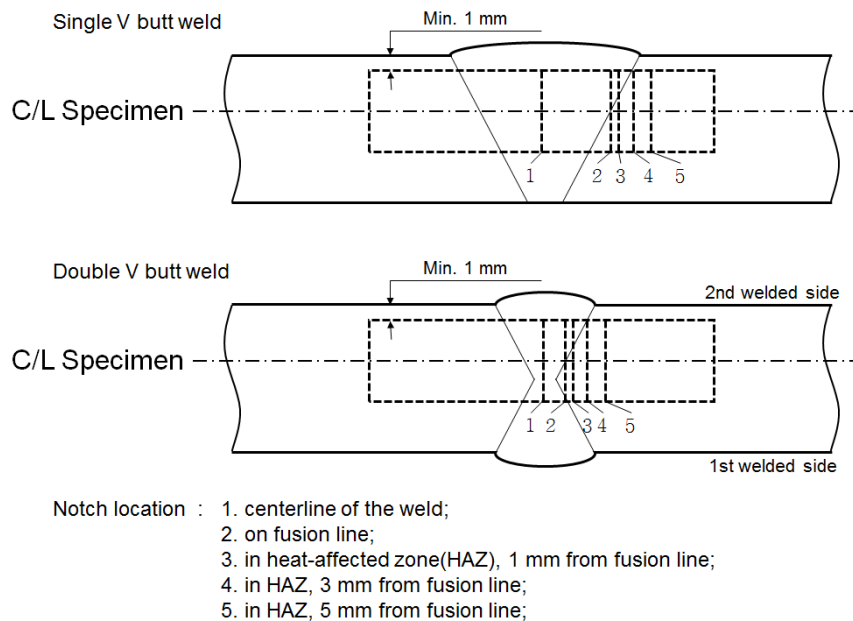

Fig 16.2 Orientation of weld test specimen

4. If the average value of the three initial Charpy V-notch specimens fails to meet the stated regulations, or the value for more than one specimen is below the required average value, or when the value for one specimen is below the minimum value permitted for a single specimen, three additional specimens from the same material may be tested and the results combined with those previously obtained to form a new average. If this new average complies with the regulations and if no more than two individual results are lower, than the required average and no more than one result is lower than the required value for a single specimen, the piece or batch may be accepted. **[See Guidance]**

### 203. Bend test

1. The bend test may be omitted as a material acceptance test, but is required for weld tests. Where a bend test is performed, this is to be done in accordance with **Pt 2, Ch 2 of Rules for the classification of steel ships**.
2. The bend tests are to be transverse bend tests, which may be face, root or side bends at the discretion of the Society. However, longitudinal bend tests may be required in lieu of transverse bend tests in cases where the base material and weld metal have different strength levels.

## 204. Section observation and other testing

Macrosection, microsection observations and hardness tests may also be required by the Society, and they are to be carried out in accordance with **Pt 2, Ch 2 of Rules for the classification of steel ships**, where required.

## Section 3 Welding of metallic materials and non-destructive testing for the fuel containment system

### 301. General [See Guidance]

This section is to apply to primary and secondary barriers only, including the inner hull where this forms the secondary barrier. Acceptance testing is specified for carbon, carbon-manganese, nickel alloy and stainless steels, but these tests may be adapted for other materials. At the discretion of the Society, impact testing of stainless steel and aluminium alloy weldments may be omitted and other tests may be specially required for any material.

### 302. Welding consumables

Consumables intended for welding of fuel tanks are to be in accordance with **Pt 2, Ch 2, Sec 6 of Rules for the classification of steel ships**. Deposited weld metal tests and butt weld tests are to be required for all consumables. The results obtained from tensile and Charpy V-notch impact tests are to be in accordance with **Pt 2, Ch 2, Sec 6 of Rules for the classification of steel ships**. The chemical composition of the deposited weld metal is to be recorded for information.

### 303. Welding procedure tests for fuel tanks and process pressure vessels

1. Welding procedure tests for fuel tanks and process pressure vessels are required for all butt welds.
2. The test assemblies is to be representative of:
  - (1) each base material;
  - (2) each type of consumable and welding process; and
  - (3) each welding position.
3. For butt welds in plates, the test assemblies is to be so prepared that the rolling direction is parallel to the direction of welding. The range of thickness qualified by each welding procedure test is to be in accordance with **Pt 2, Ch 2, Sec 4 of Rules for the classification of steel ships**. Radiographic or ultrasonic testing may be performed at the option of the fabricator. [See Guidance]
4. The following welding procedure tests for fuel tanks and process pressure vessels are to be done in accordance with **Sec 2** with specimens made from each test assembly:
  - (1) cross-weld tensile tests;
  - (2) longitudinal all-weld testing where required by the **Pt 2, Ch 2 of Rules for the classification of steel ships**;
  - (3) transverse bend tests, which may be face, root or side bends. However, longitudinal bend tests may be required in lieu of transverse bend tests in cases where the base material and weld metal have different strength levels;
  - (4) one set of three Charpy V-notch impacts, generally at each of the following locations, as shown in **Fig 16.2**:
    - (A) centreline of the welds;
    - (B) fusion line;
    - (C) 1 mm from the fusion line;
    - (D) 3 mm from the fusion line; and
    - (E) 5 mm from the fusion line;
  - (5) macrosection, microsection and hardness survey may also be required.
5. Each test is to satisfy the following: [See Guidance]
  - (1) tensile tests: cross-weld tensile strength is not to be less than the specified minimum tensile strength for the appropriate parent materials. For aluminium alloys, reference is to be made to **Ch 6, 412. 1 (1) (C)** with regard to the regulations for weld metal strength of under-matched

welds (where the weld metal has a lower tensile strength than the parent metal). In every case, the position of fracture is to be recorded for information;

- (2) bend tests: no fracture is acceptable after a 180° bend over a former of a diameter four times the thickness of the test pieces; and
  - (3) Charpy V-notch impact tests: Charpy V-notch tests is to be conducted at the temperature prescribed for the base material being joined. The results of weld metal impact tests, minimum average energy (KV), is to be no less than 27J. The weld metal regulations for sub-size specimens and single energy values are to be in accordance with **Ch 16, 202..** The results of fusion line and heat affected zone impact tests is to show a minimum average energy (KV) in accordance with the transverse or longitudinal regulations of the base material, whichever is applicable, and for sub-size specimens, the minimum average energy (KV) is to be in accordance with **Ch 16, 202..** If the material thickness does not permit machining either full-size or standard sub-size specimens, the testing procedure and acceptance standards are to be in accordance with recognized standards.
6. Procedure tests for fillet welding is to be in accordance with **Pt 2, Ch 2 of Rules for the classification of steel ships**. In such cases, consumables are to be so selected that exhibit satisfactory impact properties.

### 304. Welding procedure tests for piping [See Guidance]

Welding procedure tests for piping is to be carried out and is to be similar to those detailed for fuel tanks in **303**.

### 305. Production weld tests [See Guidance]

1. For all fuel tanks and process pressure vessels except membrane tanks, production weld tests are to generally be performed for approximately each 50 m of butt-weld joints and are to be representative of each welding position. For secondary barriers, the same type production tests as required for primary tanks are to be performed, except that the number of tests may be reduced subject to agreement with the Society. Tests, other than those specified in **2** to **5** may be required for fuel tanks or secondary barriers.
2. The production tests for types A and B independent tanks are to include bend tests and, where required for procedure tests, one set of three Charpy V-notch tests. The tests are to be made for each 50 m of weld. The Charpy V-notch tests are to be made with specimens having the notch alternately located in the centre of the weld and in the heat affected zone (most critical location based on procedure qualification results). For austenitic stainless steel, all notches are to be in the centre of the weld.
3. For type C independent tanks and process pressure vessels, transverse weld tensile tests are required in addition to the tests listed in **2**. Tensile tests are to meet regulation **303. 5**.
4. The quality assurance/quality control (QA/QC) program is to ensure the continued conformity of the production welds as defined in the material manufacturers quality manual (QM).
5. The test regulations for membrane tanks are the same as the applicable test regulations listed in **3**.

### 306. Non-destructive testing [See Guidance]

1. All test procedures and acceptance standards are to be in accordance with recognized standards, unless the designer specifies a higher standard in order to meet design assumptions. Radiographic testing is to be used in principle to detect internal defects. However, an approved ultrasonic test procedure in lieu of radiographic testing may be conducted, but in addition supplementary radiographic testing at selected locations is to be carried out to verify the results. Radiographic and ultrasonic testing records are to be retained.
2. For type A independent tanks where the design temperature is below -20 °C, and for type B independent tanks, regardless of temperature, all full penetration butt welds of the shell plating of fuel tanks are to be subjected to non-destructive testing suitable to detect internal defects over their full length. Ultrasonic testing in lieu of radiographic testing may be carried out under the same conditions as described in **1**.

3. In each case the remaining tank structure, including the welding of stiffeners and other fittings and attachments, is to be examined by magnetic particle or dye penetrant methods as considered necessary.
4. For type C independent tanks, the extent of non-destructive testing is to be total or partial according to recognized standards, but the controls to be carried out are not to be less than the following:
  - (1) Total non-destructive testing referred to in **Ch 6, 415. 3 (2) (A) (c)**. As an alternative, ultrasonic testing, as described in **1**, may be accepted as a partial substitute for the radiographic testing. In addition, this Society may require total ultrasonic testing on welding of reinforcement rings around holes, nozzles, etc.
    - (A) Radiographic testing: all butt welds over their full length.
    - (B) Non-destructive testing for surface crack detection:
      - (a) all welds over 10 % of their length;
      - (b) reinforcement rings around holes, nozzles, etc. over their full length.
  - (2) Partial non-destructive testing referred to in **Ch 6, 415. 3 (2) (A) (c)** :
    - (A) Radiographic testing: all butt welded crossing joints and at least 10 % of the full length of butt welds at selected positions uniformly distributed.
    - (B) Non-destructive testing for surface crack detection: reinforcement rings around holes, nozzles, etc. over their full length.
    - (C) Ultrasonic testing: as may be required by the Society in each instance.
5. The quality assurance/quality control (QA/QC) program are to ensure the continued conformity of the non-destructive testing of welds, as defined in the material manufacturer's quality manual (QM).
6. Inspection of piping is to be carried out in accordance with the regulations of **Ch 7**.
7. The secondary barrier is to be non-destructive tested for internal defects as considered necessary. Where the outer shell of the hull is part of the secondary barrier, all sheer strake butts and the intersections of all butts and seams in the side shell are to be tested by radiographic testing.

## Section 4 Other regulations for construction in metallic materials

### 401. General

Inspection and non-destructive testing of welds are to be in accordance with regulations in **305.** and **306.** Where higher standards or tolerances are assumed in the design, they are to also be satisfied.

### 402. Independent tank

For type C tanks and type B tanks primarily constructed of bodies of revolution the tolerances relating to manufacture, such as out-of-roundness, local deviations from the true form, welded joints alignment and tapering of plates having different thicknesses, are to comply with recognized standards. The tolerances are to also be related to the buckling analysis referred to in **Ch 6, 415. 2 (3) (A)** and **Ch 6, 415. 3 (3) (B)**.

### 403. Secondary barriers

During construction the regulations for testing and inspection of secondary barriers are to be approved or accepted by this Society (see also **Ch 6, 404. 5** and **Ch 6, 404. 6**).

### 404. Membrane tanks [See Guidance]

The quality assurance/quality control (QA/QC) program are to ensure the continued conformity of the weld procedure qualification, design details, materials, construction, inspection and production testing of components. These standards and procedures are to be developed during the prototype testing programme.

## Section 5 Testing

### 501. Testing and inspections during construction

1. All liquefied gas fuel tanks and process pressure vessels are to be subjected to hydrostatic or hydro-pneumatic pressure testing in accordance with **502.** to **505.**, as applicable for the tank type.
2. All tanks are to be subject to a tightness test which may be performed in combination with the pressure test referred to in **1.** **[See Guidance]**
3. The gas tightness of the fuel containment system with reference to **Ch 6, 301. 3** is to be tested.
4. Regulations with respect to inspection of secondary barriers are to be decided by the Society in each case, taking into account the accessibility of the barrier (see also **Ch 6, 401. 4**).
5. The Society may require that for ships fitted with novel type B independent tanks, or tanks designed according to **Ch 6, 416.** at least one prototype tank and its support are to be instrumented with strain gauges or other suitable equipment to confirm stress levels during the testing required in **1.** Similar instrumentation may be required for type C independent tanks, depending on their configuration and on the arrangement of their supports and attachments. **[See Guidance]**
6. The overall performance of the fuel containment system is to be verified for compliance with the design parameters during the first LNG bunkering, when steady thermal conditions of the liquefied gas fuel are reached, in accordance with the requirements of the Society. Records of the performance of the components and equipment, essential to verify the design parameters, are to be maintained on board and be available to the Society. **[See Guidance]**
7. The fuel containment system is to be inspected for cold spots during or immediately following the first LNG bunkering, when steady thermal conditions are reached. Inspection of the integrity of thermal insulation surfaces that cannot be visually checked is to be carried out in accordance with the requirements of the Society. **[See Guidance]**
8. Heating arrangements, if fitted in accordance with **Ch 6, 413. 1 (1) (C)** and **Ch 6, 413. 1 (1) (D)**, are to be tested for required heat output and heat distribution.

### 502. Type A independent tanks **[See Guidance]**

All type A independent tanks is to be subjected to a hydrostatic or hydro-pneumatic pressure testing. This test is to be performed such that the stresses approximate, as far as practicable, the design stresses, and that the pressure at the top of the tank corresponds at least to the MARVS. When a hydro-pneumatic test is performed, the conditions are to simulate, as far as practicable, the design loading of the tank and of its support structure including dynamic components, while avoiding stress levels that could cause permanent deformation.

### 503. Type B independent tanks **[See Guidance]**

Type B independent tanks are to be subjected to a hydrostatic or hydro-pneumatic pressure testing as follows:

- (1) The test is to be performed as required in **502.** for type A independent tanks.
- (2) In addition, the maximum primary membrane stress or maximum bending stress in primary members under test conditions is not to exceed 90 % of the yield strength of the material (as fabricated) at the test temperature. To ensure that this condition is satisfied, when calculations indicate that this stress exceeds 75 % of the yield strength the test of the first of a series of identical tanks is to be monitored by the use of strain gauges or other suitable equipment.

### 504. Type C independent tanks and other pressure vessels **[See Guidance]**

1. Each pressure vessel is to be subjected to a hydrostatic test at a pressure measured at the top of the tanks, of not less than  $1.5 P_0$ . In no case during the pressure test is to the calculated primary membrane stress at any point exceed 90 % of the yield strength of the material at the test temperature. To ensure that this condition is satisfied where calculations indicate that this stress will exceed 0.75 times the yield strength, the test of the first of a series of identical tanks is to be monitored by the use of strain gauges or other suitable equipment in pressure vessels other than

simple cylindrical and spherical pressure vessels.

2. The temperature of the water used for the test is to be at least 30 °C above the nil-ductility transition temperature of the material, as fabricated.
3. The pressure is to be held for 2 hours per 25 mm of thickness, but in no case less than 2 hours.
4. Where necessary for liquefied gas fuel pressure vessels, a hydro-pneumatic test may be carried out under the conditions prescribed in 1 to 3.
5. Special consideration may be given to the testing of tanks in which higher allowable stresses are used, depending on service temperature. However, regulation in 1. is to be fully complied with.
6. After completion and assembly, each pressure vessel and its related fittings are to be subjected to an adequate tightness test, which may be performed in combination with the pressure testing referred to in 1 or 4 as applicable.
7. Pneumatic testing of pressure vessels other than liquefied gas fuel tanks is to be considered on an individual case basis. Such testing is to only be permitted for those vessels designed or supported such that they cannot be safely filled with water, or for those vessels that cannot be dried and are to be used in a service where traces of the testing medium cannot be tolerated.

#### 505. Membrane tanks [See Guidance]

##### 1. Design development testing

- (1) The design development testing required in **Ch 6, 415. 4 (1) (B)** is to include a series of analytical and physical models of both the primary and secondary barriers, including corners and joints, tested to verify that they will withstand the expected combined strains due to static, dynamic and thermal loads at all filling levels. This will culminate in the construction of a prototype scaled model of the complete liquefied gas fuel containment system. Testing conditions considered in the analytical and physical model are to represent the most extreme service conditions the liquefied gas fuel containment system will be likely to encounter over its life. Proposed acceptance criteria for periodic testing of secondary barriers required in **Ch 6, 415. 4 (1) (B)** may be based on the results of testing carried out on the prototype scaled model.
- (2) The fatigue performance of the membrane materials and representative welded or bonded joints in the membranes are to be determined by tests. The ultimate strength and fatigue performance of arrangements for securing the thermal insulation system to the hull structure are to be determined by analyses or tests.

##### 2. Testing

- (1) In ships fitted with membrane liquefied gas fuel containment systems, all tanks and other spaces that may normally contain liquid and are adjacent to the hull structure supporting the membrane, is to be hydrostatically tested.
- (2) All hold structures supporting the membrane are to be tested for tightness before installation of the liquefied gas fuel containment system.
- (3) Pipe tunnels and other compartments that do not normally contain liquid need not be hydrostatically tested.

## Section 6 Welding, post-weld heat treatment and non-destructive testing

### 601. General

Welding is to be carried out in accordance with **Sec 3**.

### 602. Post-weld heat treatment

Post-weld heat treatment is to be required for all butt welds of pipes made with carbon, carbon-manganese and low alloy steels. The Society may waive the regulations for thermal stress relieving of pipes with wall thickness less than 10 mm in relation to the design temperature and pressure of the piping system concerned.

### 603. Non-destructive testing

In addition to normal controls before and during the welding, and to the visual inspection of the finished welds, as necessary for proving that the welding has been carried out correctly and according to the regulations in this Article, the following tests are to be required:

- (1) 100 % radiographic or ultrasonic inspection of butt-welded joints for piping systems with;
  - (A) design temperatures colder than minus 10 °C; or
  - (B) design pressure greater than 1.0 MPa; or
  - (C) gas supply pipes in ESD protected machinery spaces; or
  - (D) inside diameters of more than 75 mm; or
  - (E) wall thicknesses greater than 10 mm.
- (2) When such butt welded joints of piping sections are made by automatic welding procedures approved by the Society, then a progressive reduction in the extent of radiographic or ultrasonic inspection can be agreed, but in no case to less than 10 % of each joint. If defects are revealed the extent of examination are to be increased to 100 % and are to include inspection of previously accepted welds. This approval can only be granted if well-documented quality assurance procedures and records are available to assess the ability of the manufacturer to produce satisfactory welds consistently.
- (3) The radiographic or ultrasonic inspection regulation may be reduced to 10 % for butt-welded joints in the outer pipe of double-walled fuel piping.
- (4) For other butt-welded joints of pipes not covered by (1) and (3), spot radiographic or ultrasonic inspection or other non-destructive tests are to be carried out depending upon service, position and materials. In general, at least 10 % of butt-welded joints of pipes are to be subjected to radiographic or ultrasonic inspection.

## Section 7 Testing Regulations

### 701. Testing of piping components

#### 1. Valves [See Guidance]

Valves intended to be used at a working temperature below -55 °C are to be type approved in accordance with the procedure required in **Ch 3, Sec 15 of Guidance for approval of Manufacturing Process and Type approval, Etc..**

#### 2. Expansion bellows

Expansion bellows intended for use on fuel piping outside the fuel tank and, where required by the Society, on those expansion bellows installed within the fuel tanks is to be type approved in accordance with the procedure required in **Ch 3, Sec 15 of Guidance for approval of Manufacturing Process and Type approval, Etc..**

### 702. Testing of piping systems

1. The regulations for testing in this section apply to fuel piping inside and outside the fuel tanks. However, relaxation from these requirements for piping inside fuel tanks and open ended piping may be accepted
2. After assembly, all fuel piping is to be subjected to a strength test with a suitable fluid. The test pressure is to be at least 1.5 times the design pressure for liquid lines and 1.5 times the maximum system working pressure for vapour lines. When piping systems or parts of systems are completely manufactured and board is to be tested to at least 1.5 times the design pressure.
3. After assembly on board, the fuel piping system is to be subjected to a leak test using air, or other suitable medium to a pressure depending on the leak detection method applied.
4. In double wall fuel piping systems the outer pipe or duct is to also be pressure tested to show that it can withstand the expected maximum pressure at pipe rupture.
5. All piping systems, including valves, fittings and associated equipment for handling fuel or vapours, are to be tested under normal operating conditions not later than at the first bunkering operation, in accordance with recognized standards.

6. Emergency shutdown valves in liquefied gas piping systems are to close fully and smoothly within 30 s of actuation. Information about the closure time of the valves and their operating characteristics are to be available on board, and the closing time is to be verifiable and repeatable.
7. The closing time of the valve referred to in **Ch 8, 501. 8** and **Ch 15, 401. 2 (2)** (i.e. time from shutdown signal initiation to complete valve closure) is not to be greater than:

$$\frac{3,600U}{BR} \quad (\text{sec})$$

where:

$U$  = ullage volume at operating signal level ( $\text{m}^3$ )

$BR$  = maximum loading rate agreed between ship and shore facility ( $\text{m}^3/\text{h}$ );

or 5 seconds, whichever is the least.

The bunkering rate is to be adjusted to limit surge pressure on valve closure to an acceptable level, taking into account the loading hose or arm, the ship and the shore piping systems, where relevant.

### 703. Test of fuel pumps and gas compressors [See Guidance]

The test of fuel pumps and gas compressors are to be in accordance with the Guidance specified separately. ↓



**2019**

---

**Guidances Relating to  
the Rules for the Classification of  
Ships Using Low-flashpoint Fuels**

#### APPLICATION OF THE GUIDANCE RELATING TO THE RULES

This "Guidance Relating to the Rules for the Classification of Ships Using Low-flashpoint Fuels" (hereafter called as the Guidance Relating to the Rules) is prepared with the intent of giving details as to the treatment of the various provisions for items required the unified interpretations and items not specified in the Rules, and the requirements specified in the Guidance Relating to the Rules are to be applied, in principle, in addition to the various provisions in the Rules.

As to any technical modifications which can be regarded as equivalent to any requirements in the Guidance Relating to the Rules, their flexible application will be properly considered.

# APPLICATION OF "GUIDANCE RELATING TO THE RULES FOR THE CLASSIFICATION OF SHIPS USING LOW-FLASHPOINT FUELS"

1. Unless expressly specified otherwise, the requirements in the Guidance apply to Ships using low-flashpoint fuels for which contracts for construction are signed on or after 1 July 2019.
2. The amendments to the Guidance for 2018 version and their effective date are as follows;

**Effective Date 1 July 2018**

---

## **CHAPTER 15 CONTROL, MONITORING AND SAFETY SYSTEMS**

- Section 4 Bunkering and liquefied gas fuel tank monitoring  
- 402. 2 has been deleted.

**Effective Date 1 January 2019**

---

## **Annex 3 Risk assessment**

- Annex 3 has been newly added.

**Effective Date 1 July 2019**

---

## **CHAPTER 1 GENERAL**

- Section 1 General  
- 102. 5 has been amended.

## **CHAPTER 5 SHIP DESIGN AND ARRANGEMENT**

- Section 4 Machinery Space Concepts  
- 401. has been amended.

- Section 8 Fuel Preparation Room  
- 801. has been amended.

## **CHAPTER 6 FUEL CONTAINMENT SYSTEM**

- Section 4 Liquefied gas fuel containment  
- 404., 405., 406., 409., 412 have been newly added.  
- 413. has been amended.  
- 414. has been newly added.  
- 415. has been newly added.

- Section 7 Pressure relief system  
- 702. has been amended.

Section 8 Loading limit for liquefied gas fuel tanks  
- 801. has been newly added.

Section 9 Maintaining of fuel storage condition  
- 901. 1 has been amended.  
- 903. 1 has been amended.

## **CHAPTER 8 BUNKERING**

Section 5 Bunkering system  
- 501. have been amended.

## **CHAPTER 11 FIRE SAFETY**

Section 3 Fire protection  
- 301. 1 and 2 have been amended.

## **CHAPTER 12 EXPLOSION PREVENTION**

Section 5 Hazardous area zone  
- 502. 2, 3 and 4 have been amended.  
- 503. 2 has been amended.

## **CHAPTER 15 CONTROL, MONITORING AND SAFETY SYSTEMS**

Section 10 Ventilation  
- 1001. 1 has been amended.

## **CHAPTER 16 MANUFACTURE, WORKMANSHIP AND TESTING**

Section 2 General test regulations and specifications  
- 202. 2, 3 and 4 have been newly added.  
- 1001. 1 has been amended.

Section 3 Welding of metallic materials and non-destructive testing for the fuel containment system  
- 301. 3 has been newly added.  
- 303. 2 has been amended.  
- 305. 1 & 2 have been amended.

Section 4 Other regulations for construction in metallic materials  
- Sec.4 has been newly added.

Section 5 Testing  
- Sec.5 has been newly added.

**Annex 1            Requirements for Equipment Used for Low-flashpoint Fuel Supply Systems**

- 405. 2 has been amended.

**Annex 2            Standard for the use of limit state methodologies in the design of fuel containment systems of novel configuration**

- Annex 2 has been newly added.

## CONTENTS

<b>CHAPTER 1</b>	<b>GENERAL</b>	<b>1</b>
Section 1	General	1
<b>CHAPTER 2</b>	<b>GOAL AND FUNCTIONAL REQUIREMENTS</b>	<b>3</b>
Section 2	Functional requirements (IGF Code 3.1)	3
<b>CHAPTER 3</b>	<b>GENERAL REQUIREMENTS</b>	<b>5</b>
Section 3	Limitation of explosion consequences(IGF Code 4.3)	5
<b>CHAPTER 4</b>	<b>CLASSIFICATION SURVEYS</b>	<b>7</b>
Section 3	Periodical Surveys	7
<b>CHAPTER 5</b>	<b>SHIP DESIGN AND ARRANGEMENT</b>	<b>9</b>
Section 4	Machinery space concepts (IGF Code 5.4)	9
Section 7	Location and protection of fuel piping (IGF Code 5.7)	9
Section 8	Fuel preparation room (IGF Code 5.8)	9
<b>CHAPTER 6</b>	<b>FUEL CONTAINMENT SYSTEM</b>	<b>11</b>
Section 3	General requirements (IGF Code 6.3)	11
Section 4	Liquefied gas fuel containment (IGF Code 6.4)	11
Section 7	Pressure relief system (IGF Code 6.7)	22
Section 8	Loading limit for liquefied gas fuel tanks (IGF Code 6.7)	23
Section 9	Maintaining of fuel storage condition (IGF Code 6.9)	23
<b>CHAPTER 7</b>	<b>MATERIAL AND GENERAL PIPE DESIGN</b>	<b>25</b>
Section 3	Pipe design (IGF Code 7.3)	25
Section 4	Materials (IGF Code 7.4)	26
<b>CHAPTER 8</b>	<b>BUNKERING AND FUEL SUPPLY</b>	<b>27</b>
Section 3	Bunkering station (IGF Code 8.3)	27
Section 5	Bunkering equipment (IGF Code 8.5)	27
<b>CHAPTER 9</b>	<b>FUEL SUPPLY TO CONSUMERS</b>	<b>29</b>
Section 4	Safety functions of gas supply system (IGF Code 9.4)	29
Section 5	Fuel distribution outside of machinery space (IGF Code 9.5)	29
Section 6	Fuel supply to consumers in gas-safe machinery spaces (IGF Code 9.6)	29
<b>CHAPTER 10</b>	<b>POWER GENERATION INCLUDING PROPULSION AND OTHER GAS CONSUMER</b>	<b>31</b>
Section 3	Internal combustion engines of piston type (IGF Code 10.3)	31
<b>CHAPTER 11</b>	<b>FIRE SAFETY</b>	<b>33</b>
Section 3	Fire protection (IGF Code 11.3)	33
<b>CHAPTER 12</b>	<b>EXPLOSION PREVENTION</b>	<b>35</b>
Section 4	Area classification	35
Section 5	Hazardous area zone	35

<b>CHAPTER 13 VENTILATION .....</b>	<b>37</b>
Section 3 General requirements (IGF Code 13.3) .....	37
Section 5 Machinery space (IGF Code 13.5) .....	37
Section 8 Ducts and double pipes (IGF Code 13.8) .....	38
<b>CHAPTER 14 ELECTRICAL INSTALLATIONS .....</b>	<b>39</b>
Section 3 General requirements (IGF Code 14.3) .....	39
<b>CHAPTER 15 CONTROL, MONITORING AND SAFETY SYSTEMS .....</b>	<b>41</b>
Section 3 General requirements (IGF Code 15.3) .....	41
Section 4 Bunkering and liquefied gas fuel tank monitoring (IGF Code 15.4) .....	41
Section 8 Gas detection (IGF Code 15.8) .....	41
Section 10 Ventilation (IGF Code 15.10) .....	41
<b>CHAPTER 16 MANUFACTURE, WORKMANSHIP AND TESTING .....</b>	<b>43</b>
Section 1 General requirements (IGF Code 16.1) .....	43
Section 2 General test regulations and specifications (IGF Code 16.2) .....	43
Section 3 Welding of metallic materials and non-destructive testing for the fuel containment system (IGF Code 16.3) .....	44
Section 4 Other Regulations for Construction in Metallic Materials (IGF Code 16.4) .....	46
Section 5 Testing (IGF Code 16.5) .....	46
Section 7 Testing regulations .....	49
<b>&lt;ANNEX&gt;</b>	
Annex 1 Requirements for Equipment Used for Low-flashpoint Fuel Supply Systems .....	51
Annex 2 Standard for the use of limit state methodologies in the design of fuel containment systems of novel configuration .....	73
Annex 3 Risk assessment .....	79

## CHAPTER 1 GENERAL

### Section 1 General

#### 102. Definitions

1. In applying **102. 4** of this Rules, “recognized standard“ means **IEC 60079** series and **IEC 60092-502** and electrical equipment that is certified safe by the relevant authorities recognized by the Society means the following (1) or (2): **[See Rules]**
  - (1) That having passed type test for explosion-protected electrical equipment for each type in accordance with **Pt 6, Ch 1, table 6.1.1, 13 of Rules for the classification of steel ships** or that deemed unlikely to cause the ignition; or
  - (2) That evaluated and certified/registered safe by the relevant authorities recognized by the Society.
2. In applying **102. 11** of this Rules, enclosed space means any space within which, in the absence of artificial ventilation, the ventilation will be limited and any explosive atmosphere will not be dispersed naturally. **[See Rules]**
3. In applying **102. 15 (3)** of this Rules, a tank connection space may be required also for tanks on open deck. This may apply for ships where restriction of hazardous areas is safety critical. A tank connection space may also be necessary in order to provide environmental protection for essential safety equipment related to the gas fuel system like tank valves, safety valves and instrumentation. **[See Rules]**
4. In applying **102. 15 (3)** of this Rules, a tank connection space which has equipment such as vaporizers or heat exchangers installed inside is not regarded as a fuel preparation room. Such equipment is considered to only contain potential sources of release, but not sources of ignition. **[See Rules]**
5. In applying **102. 17** of this Rules, a tank connection space which has equipment such as vaporizers or heat exchangers installed inside is not regarded as a fuel preparation room. Such equipment is considered to only contain potential sources of release, but not sources of ignition. **[See Rules]**
6. In applying **102. 38** of this Rules, semi-enclosed space means a space limited by decks and or bulkheads in such manner that the natural conditions of ventilation are notably different from those obtained on open deck. **[See Rules]** ↓

---

## CHAPTER 2 GOAL AND FUNCTIONAL REQUIREMENTS

### Section 2 Functional Requirements

#### 201. Functional requirements

1. In applying **201. 1** of this Rules, dependability means the collective term used to describe the availability performance and its influencing factors: reliability performance, maintainability performance and maintenance support performance. **[See Rules]** ↓

---

## CHAPTER 3 GENERAL REQUIREMENTS

### Section 3 Limitation of explosion consequences

#### 301. Limitation of explosion consequences [See Rules]

1. In applying 301. of this Rules, double wall fuel pipes are not considered as potential sources of release.⤵

## CHAPTER 4 CLASSIFICATION AND SURVEYS

### Section 3 Periodical Surveys

#### 303. Special Survey

1. In applying **303. 8** of this Rules, liquefied gas fuel storage tanks are to be examined based upon followings; **[See Rules]**

- (1) All Fuel tanks are to be examined internally. Vacuum insulated independent fuel storage tanks of type C need not be examined internally. Where fitted, the vacuum monitoring system should be examined and records should be reviewed.
- (2) Special attention is to be given to the fuel tank and insulation in way of chocks, supports and keys. The tank insulation and tank support arrangements should be visually examined. Removal of insulation may be required in order to verify the condition of the tank or the insulation itself if found necessary by the Surveyor. Non-destructive testing may be required if conditions raise doubt to the structural integrity.

Where the arrangement is such that the insulation cannot be examined, the surrounding structures of wing tanks, double bottom tanks and cofferdams are to be examined for cold spots when the fuel tanks are in the cold condition unless voyage records together with the instrumentation give sufficient evidence of the integrity of the insulation system.

- (3) Non-destructive testing:
  - (A) Non-destructive testing is to supplement fuel tank inspection with special attention to be given to the integrity of the main structural members, tank shell and highly stressed parts, including welded connections as deemed necessary by the surveyor. However, for type C tanks, this does not mean that non-destructive testing can be dispensed with totally. The following items are, inter alia, considered as highly stressed parts:
    - fuel tanks supports and anti-rolling/anti-pitching devices
    - web frames or stiffening rings
    - swash bulkhead boundaries
    - dome and stump connections to tank shell
    - foundations for pumps, towers, ladders, etc.
    - pipe connections
  - (B) For independent tanks type B, the extent of non-destructive testing shall be as given in a programme specially prepared for the fuel tank design.
- (4) The tightness of all fuel tanks is to be verified by an appropriate procedure. Provided that the effectiveness of the ship's gas detection equipment has been confirmed, it will be acceptable to utilize this equipment for the tightness test of independent tanks below deck.
- (5) Where findings of (1) to (4) or an examination of the voyage records raises doubts as to the structural integrity of a fuel tank, a hydraulic or hydro-pneumatic test is to be carried out. For independent tank type A and B, the test pressure is to be carried out in accordance with proper pressure based on design of each tank. For independent tanks type C, the test pressure is not to be less than 1.25 times the MARVS.
- (6) At every other special survey (i.e., 2nd, 4th, 6th, etc.), all independent fuel tanks type C are to be either:
  - (A) Hydraulically or hydro-pneumatically tested to 1.25 times MARVS, followed by non-destructive testing in accordance with (3) (A), or
  - (B) Subjected to a thorough, planned non-destructive testing. This testing is to be carried out in accordance with a programme specially prepared for the tank design. If a special programme does not exist, the following applies:
    - fuel tank supports and anti-rolling/anti-pitching devices,
    - stiffening rings,
    - Y-connections between tank shell and a longitudinal bulkhead of bilobe tanks,
    - swash bulkhead boundaries,
    - dome and sump connections to the tank shell,
    - foundations for pumps, towers, ladders etc.,
    - pipe connections.

At least 10% of the length of the welded connections in each of the above mentioned areas is to be tested. This testing is to be carried out internally and externally as applicable. Insulation

is to be removed as necessary for the required non-destructive testing.

- (7) As far as practicable all hold spaces and hull insulation (if provided), secondary barriers and tank supporting structures are to be visually examined. The secondary barrier of all tanks is to be checked for their effectiveness by means of a pressure/vacuum test, a visual examination or another acceptable method.
- (8) Membrane tanks systems,
  - (A) For membrane tank systems, inspection and testing are to be carried out in accordance with programmes specially prepared in accordance with an approved method for the actual tank system.
  - (B) For membrane storage systems a tightness test of the primary and secondary barrier shall be carried out in accordance with the system designers' procedures and acceptance criteria as approved by the classification society. Low differential pressure tests may be used for monitoring the fuel storage system performance, but are not considered an acceptable test for the tightness of the secondary barrier.
  - (C) For membrane storage systems with glued secondary barriers if the designer's threshold values are exceeded, an investigation is to be carried out and additional testing such as thermographic or acoustic emissions testing should be carried out.
- (9) The pressure/vacuum relief valves, rupture disc and other pressure relief devices for interbarrier spaces and hold spaces are to be opened, examined, tested and readjusted as necessary, depending on their design.
- (10) The pressure relief valves for the fuel tanks are to be opened for examination, adjusted, function tested, and sealed. If the fuel tanks are equipped with relief valves with non-metallic membranes in the main or pilot valves, such non-metallic membranes are to be replaced. Where a proper record of continuous overhaul and retesting of individually identifiable relief valves is maintained, consideration will be given to acceptance on the basis of opening, internal examination, and testing of a representative sampling of valves, including each size and type of liquefied gas or vapor relief valve in use, provided there is logbook evidence that the remaining valves have been overhauled and tested since crediting of the previous Special Survey. ↓

## CHAPTER 5 SHIP DESIGN AND ARRANGEMENT

### Section 4 Machinery Space Concepts

#### 401. Machinery space concepts

1. In applying 401. of this Rules, premixed engines using fuel gas mixed with air before the turbo-charger shall be located in ESD protected machinery spaces. **[See Rules]**

### Section 7 Location and Protection of Fuel Piping

#### 701. Location and protection of fuel piping

1. In applying 701. 2 of this Rules, electrical equipment rooms includes auto-telephone exchange and air-conditioning duct spaces. **[See Rules]**

### Section 8 Fuel Preparation Room

#### 801. Fuel preparation room **[See Rules]**

1. Fuel preparation rooms, regardless of location, is to be arranged to safely contain cryogenic leakages.
2. The material of the boundaries of the fuel preparation room is to have a design temperature corresponding with the lowest temperature it can be subjected to in a probable maximum leakage scenario unless the boundaries of the space, i.e. bulkheads and decks, are provided with suitable thermal protection.
3. The fuel preparation room is to be arranged to prevent surrounding hull structure from being exposed to unacceptable cooling, in case of leakage of cryogenic liquids.
4. The fuel preparation room is to be designed to withstand the maximum pressure build up during such a leakage. Alternatively, pressure relief venting to a safe location (mast) can be provided.↓

## CHAPTER 6 FUEL CONTAINMENT SYSTEM

### Section 3 General Requirements

#### 301. General requirements

1. In applying **301. 5** of this Rules, special consideration by the Society means to comply with the requirement specified in **301. 9** of this Rules. **[See Rules]**
2. In applying **301. 10** of this Rules, whether a drip tray is needed or not is to be in accordance with the following: **[See Rules]**
  - (1) When the tank is located on the open deck, drip trays are to be provided to protect the deck from leakages from tank connections and other sources of leakage.
  - (2) When the tank is located below the open deck but the tank connections are on the open deck, drip trays are to be provided to protect the deck from leakages from tank connections and other sources of leakage.
  - (3) When the tank and the tank connections are located below the deck, all tank connections are to be located in a tank connection space. Drip trays in this case are not required.

### Section 4 Liquefied gas fuel containment

#### 404. Design of secondary barriers (2019)

1. In applying **404.** of the Rules, the secondary barriers of nonmetal material are to conform to the following requirements : **[See Rules]**
  - (1) Compatibility with the fuel is to have been verified, and to have necessary mechanical properties at the fuel temperature under the atmospheric pressure.
  - (2) A model test may be required to prove that the secondary barrier has effective performance when the Society deems it necessary.
  - (3) For joints, joining procedure tests and production test are to be conducted. The test plans for the above are to have been approved by the Society beforehand.
2. In applying **404. 1** of the Rules, no special analysis of the complete secondary barrier for verifying that "it is capable of containing any envisaged leakage of liquid fuel for a period of 15 days" may be carried out except for cases where the Society deems it specially necessary. **[See Rules]**
3. In applying **404. 4** of the Rules, the test procedure where visual inspection of the secondary barrier is not possible is to be in accordance with the following requirements : **[See Rules]**
  - (1) The inspection method of the secondary barrier and its criteria relating to the performance to act as the secondary barrier are to be verified for their effectiveness through model test.
  - (2) The secondary barrier is to be verified by model test for the required performance. This model test is to be capable of verifying that the secondary barrier can maintain the necessary performance throughout the life of the ship.
  - (3) When sufficient data to prove the effectiveness and reliability relative to the preceding (1) and (2) are submitted to the satisfaction of the Society, this model test may be omitted.

#### 405. Partial secondary barriers and primary barrier small leak protection system (2019)

**[See Rules]**

##### 1. Partial secondary barrier

- (1) The protection of the inner bottom plating at the lower part of fuel tanks is to conform to the following requirements :
  - (A) In case where a drip tray is provided as a secondary barrier for example as shown in **Fig 6.1** with consideration so as not to allow the leaked liquid fuel to overflow from the secondary barrier, no protection may be required. However, where no such consideration is taken, the inner bottom plating is to be protected by insulation materials.

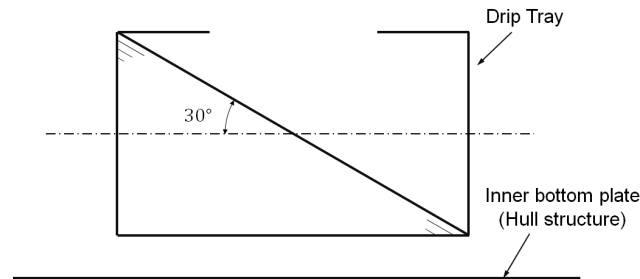

**Fig. 6.1 Drip Tray to protect the inner bottom plate**

- (2) The spray shield specified in **405. 1** of the Rules is to have been verified by test that it has satisfactory performance to act as the shield. **[See Rules]**

#### **406. Supporting Arrangement (2019) [See Rules]**

1. In spaces between the refrigerated tanks and supports, suitable insulation materials are to be provided so that hull structure might not be cooled excessively through the supporting structures according to requirement of **413. 1** of the Rules.

#### **408. Thermal insulation [See Rules]**

1. In applying **408.** of this Rules, the insulation of vacuum insulated tanks is to be as deemed appropriated by the Society.

#### **409. Design Loads (2019)**

##### **1. Thermally induced loads**

- (1) In applying **409. 3 (3) (C) (a)** of the Rules, arrangements for cooling down are to be provided so as not to cause excessive stress on the tank structures.
- (2) The arrangements shown in the preceding (1) are to be such that safety in cooling down using the arrangements has been proved by records of fuel tanks of similar design or cooling down operation is performed at a rate not exceeding the safe temperature reduction curve which has been proved by thermal stress analysis.
- (3) The installations shown in the preceding (1) are to be also capable of performing cooling down at time when excessive thermal loads may be anticipated due to splashing of the residual fuel liquid in ballast passage of the ship under heavy weather as well as at time of fuel loading.
- (4) In applying **409. 3 (3) (C) (b)** of the Rules, the structural strength is to be verified through thermal stress analysis by taking into account the vertical temperature distribution at time of cooling down and partial fuel loading, and when necessary, the temperature distribution in the direction of the plate thickness of plating of full loaded tanks. **[See Rules]**
- (5) For tanks other than those specified in the preceding (4), the Society may request thermal stress analysis of the fuel tank by taking into account the constraining condition of the fuel tank by tank supporting structure in case where the tank supporting system is special, and thermal analysis in consideration of the effect of materials with different coefficients of thermal expansion in case where such materials are used.
- (6) In the cases referred to in the preceding (4) and (5) where the type of tank supporting system is special, the Society may request thermal analysis on the tank supporting structure itself.

##### **2. Vibration**

- (1) In applying **409. 3 (3) (D)** of the Rules, the liquefied gas fuel tank plates and stiffeners are to have such scantlings as not to be caused harmful effects by resonance with the vibrations of exciting sources such as propeller and main engine. The natural frequencies of the liquefied gas fuel tanks and stiffeners used in the above assessment are to be minimum values in a state in contact with fuel liquid. **[See Rules]**

### 3. Static heel loads [See Rules]

- (1) In applying **419. 3 (3) (H)** of the Rules, the added mass due to hull damage or flooding may not be considered.

### 4. Loads due to ship motion

- (1) The "Ships for the restricted service" referred to in **409. 4 (1) (A)** of the Rules means those ships with notations "Coasting Service" or "Smooth Water Service" affixed. In this case, the dynamic load may be determined by the results of calculation of ship motions carried out on the basis of the data on sea and weather conditions at the navigating area which are considered appropriately by the Society. [See Rules]

### 5. Sloshing Loads

- (1) In applying **409. 4 (1) (C)** of the Rules, sloshing loads are to be determined in such a way that assessments are made by model experiment for each type of fuel tanks. Data concerning the resonant period of the hull and natural period of the liquids are to be available on board the ship for avoiding the danger of resonance. [See Rules]
- (2) Notwithstanding the requirements in the preceding (1), in the type C independent tank in ships with  $L_f$  not exceeding 90 m, consideration for structural strength of cargo tanks due to sloshing loads may not be necessary. However, sufficient consideration is to be taken for the installation of equipment in cargo tanks such as cargo piping and cargo pump, against impact loads due to sloshing.

## 412. Design Conditions (2019)

### 1. Ultimate design condition

- (1) In applying **412. 1 (1) (C)** of the Rules, the values of  $R_e$  and  $R_m$  when the strength of welds is less than that of the parent metal as in the case of 9% nickel steel are to be of the required values of mechanical properties of the weld metal. For welded joints of aluminium alloys 5083-O and 5083/5183 and 9% nickel steel, the values of  $R_e$  and  $R_m$  may be modified in consideration of the increase in the yield stress and tensile stress at low temperature after taking into account the welding procedure employed. [See Rules]

### 2. Fatigue design condition

- (1) In applying **412. 2** of the Rules, the stress due to fatigue load may be generally determined by using the cumulative probability curve as shown in **Fig 6.2**. [See Rules]

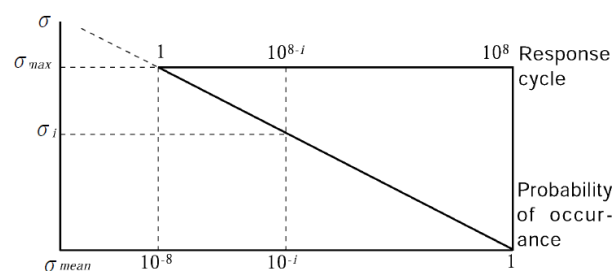

Fig 6.2 Cumulative probability curve

- (2) When the fatigue strength analysis specified in the requirements in **415. 2 (B)** of the Rules is carried out using the frequency distribution of cyclic stress shown in the preceding (1), the number of representative stress ( $\sigma_i$ ) is to be eight, and  $\sigma_i$  and its number of repetition  $n_i$  may be obtained from the following equations :

$$\sigma_i = \frac{17 - 2 \cdot i}{16} \sigma_{\max}$$

$$n_i = 0.9 \times 10^i$$

where :

$$i = 1, 2, \dots, 8$$

$\sigma_{max}$  : stress induced by the predicted maximum dynamic load

- (3) For the purpose of **412. 2** (6) of the Rules, the fatigue load used in the calculation of propagation speed of fatigue cracks is, as a rule, to be the predicted maximum load value that can occur at the most severe period in the trade area specified. In case where analysis is made by using the load frequency distribution given in **Fig 6.3** of the Rules, the number of representative stress( $\sigma_i$ ) is to be set at five and its number of repetition  $n_i$  may be obtained from the following equations : **[See Rules]**

$$\sigma_i = \frac{5.5 - i}{5.3} \sigma_{max}$$

$$n_i = 1.8 \times 10^i$$

where :

$$i = 1, 2, \dots, 5$$

$\sigma_{max}$  : stress created by the predicted maximum load

- (4) The "ships engaged in particular voyages." referred to in **412. 2** (7) of the Rules means "the ships for restricted service" of **409. 4** (1). **[See Rules]**

### 413. Materials (2019)

#### 1. Calculation the temperature of hull structures

In applying **413. 1** (1) of the Rules, the calculation conditions in computing the temperature of hull structures are to be in accordance with the following requirements : **[See Rules]**

- (1) The loading condition of the ship for the calculation is to be full loaded condition.
- (2) At the upright fuel leakage is to be considered for the calculation in accordance with the following requirements. However, no leakage may be considered for type C independent tanks.
  - (A) It is to be assumed that the failure of all fuel tanks located between transverse watertight bulkheads are caused. However, in case where the cross section of the ship is divided into more than one compartments by longitudinal bulkheads of the ship, it is to be assumed that the failure of all fuel tanks within each such compartment is caused.
  - (B) It is to be assumed that the locations of the failure of the fuel tank cover all conceivable ones.
  - (C) It is to be assumed that only the liquid fuel leaks out where the fuel tank, supports and hull remain intact without involving any deflections or fracture.
  - (D) For fuel tanks where the complete secondary barrier is required, it is to be assumed that the leakage of liquid fuel occurs instantaneously and the levels of residual liquid fuel in damaged fuel tank and the leaked liquid level in the hold space reach the same level instantaneously.
- (3) The boundary conditions of the calculation model are to be in accordance with the following requirements :
  - (A) The temperature of the compartment adjacent to fuel storage hold spaces is to be determined by heat transmission calculation. The atmosphere of the compartment which is adjacent to the compartment contiguous to fuel storage hold space may be taken as a still air at 0°C. In the case of machinery space, it may be assumed as a still air at 5°C.
  - (B) It is to be assumed that there is no radiation of sun beam.
  - (C) The structures in fuel storage hold space such as insulation materials and supports are to be assumed that they do not absorb liquid fuel.
  - (D) It is to be assumed that the gas and liquid within the same compartment are at the same temperature.
  - (E) At time of damage to the fuel tank, the gaseous phase in the fuel tank and that in fuel storage hold spaces are to be assumed to have a pressure equals to the atmospheric pressure.
  - (F) It is to be assumed that there is no transfer of gases within the insulation materials.

- (G) It is to be assumed that there is no influence of moisture.  
 (H) The ship is to be assumed to stay upright.  
 (I) It is to be assumed that there is no influence of paints.
- (4) The calculation conditions in heat transmission calculation are to be in accordance with the following requirements :
- (A) Temperature distribution and heat transmission are to be dealt with as the phenomena in a steady state. No transient condition may be considered.  
 (B) Sea water is to be assumed to have a density of  $1,025 \text{ kg/m}^3$  and a coagulation point of  $-2.5^\circ\text{C}$  with physical properties compatible with those of fresh water for other items.  
 (C) The liquid fuel is to be assumed to have uniform temperature distribution.  
 (D) The heat transfer coefficients at various boundaries can be computed by using the numeral values given in **Table 6.1**, but calculation may be carried out by using empirical equations given in the heat transfer engineering data which has been made public. In this case, heat transfer due to radiation is also to be taken into account.

**Table 6.1 The Heat Transfer Coefficient at Various Boundaries**

Boundaries	Heat transfer coefficients ( $\text{W/m}^2 \cdot ^\circ\text{C}$ )
Still gas $\leftarrow \rightarrow$ Hull or liquid	5.8
Still sea water $\leftarrow \rightarrow$ Hull	116.3
fuel vapour $\leftarrow \rightarrow$ Hull contacted to air	11.6

- (E) The substance for which temperature distribution is investigated is to be assumed to be of homogeneous one without directivity.  
 (F) Frames may be dealt with as fins.  
 (G) The cooling effect by the latent heat of evaporation of the liquid fuel may not be taken into account.  
 (H) The temperature of structural members is to be represented by the temperature at their half thickness, and for individual members, the following requirements are to be complied with :
- (a) The temperature of those frames fitted to plates is to be assumed to be the same as the temperature of the plates, but when the temperature distribution of the frame in the direction of depth is known, the area mean of the temperature distribution may be taken.  
 (b) The temperature of web frames supporting frames or plates is to be the temperature at their half depth for webs, and the temperature of face plates for these.  
 (c) The temperature of members connecting the inner shell and outer shell, e.g., brackets and girders is to be of the mean of the temperature of the inner shell and that of the outer shell.  
 (d) The temperature of brackets is to be the temperature at their centroid.

## 2. Hull material not forming secondary barrier

- (1) When the design temperature of a material falls under the higher temperature range than the specified one for the material in **Table 7.3** and **Table 7.4** of the Rules in accordance with **413. 2 (2)** of the Rules, the impact test temperature given in **Table 7.1** to **Table 7.4** of the Rules correspondingly to the design temperature may be used instead of the impact test temperature depending on the material. For example, in the case of 2.25 % nickel steel pipes used at the design temperature of  $-45^\circ\text{C}$ , the impact test temperature may be  $-50^\circ\text{C}$ , while in the case of 3.5 % nickel steel plates used at the design temperature of  $-61^\circ\text{C}$ , the impact test temperature may be  $-70^\circ\text{C}$ .

## 3. Insulation materials [See Rules]

- (1) In applying **413. 3 (1)** of the Rules, insulation materials of independent tanks are to be free from generating harmful defects that degrade the insulation performance even under such conditions of service that can actually take place in insulation structure including forced deflection and thermal expansion and contraction.  
 (2) The performance referred to in the preceding (1) is to be verified in the insulation procedure test specified in **6** below as necessary.

#### 4. Properties of insulation materials [See Rules]

- (1) In applying **413. 3 (2)** of the Rules, the properties of insulation materials are, in general, to be verified by the tests given in **Table 6.2**.
- (2) In addition to complying with the requirements in the preceding (1), property verification test may be requested by the Society depending on the insulation system.
- (3) If the material, which has been approved according to the Guidance given by the Society, satisfies the performance requirements and such performance is considered to serve the purpose, the tests referred to in the preceding (1) may be omitted.
- (4) For insulation materials to which the requirements in the preceding (1) to (3) do not apply, the following requirements are to be complied with :
  - (A) For insulation materials used for supports of independent tanks, the requirements given in the column of membrane tank in **Table 6.2** apply.
  - (B) For insulation materials provided in fuel tanks to which no provision of insulation is required according to the requirements in **408.** of the Rules, data on the necessary properties of those specified in **413. 3 (2)** of the Rules depending on the insulation system is to be submitted to the Society.
- (5) The test method for the properties specified in **413. 3 (2)** of the Rules is to be **Table 6.3** or to the satisfaction of the Society.

#### 5. Quality control of insulation materials

In applying **413. 3 (2)** of the Rules, control of manufacture, storage, handling, assembly, quality control and effect from exposure of the sun is as shown in the following requirements:

- (1) The insulation materials are to be approved in accordance with the Guidance. In the above, tests and inspection are to be conducted according to the procedures on the manufacture, storage, handling and product quality control established by the manufacturer.
- (2) The inspection for insulation work is to include the following tests and inspections :
  - (A) Insulation procedure test  
For insulation system and insulation procedure without previous records, tests are to be conducted in accordance with the test plan approved by the Society. The test may be conducted at the manufacturer of insulation materials or shipyard as necessary.
  - (B) Insulation production test  
In accordance with the test plan approved by the Society in advance, tests are to be conducted to verify the work control, working environment control and product quality control during insulation procedure.
  - (C) Completion inspection  
After the insulation work is completed, inspection is to be conducted for dimensions, shape, appearance, etc. in accordance with the procedures already approved by the Society, and in addition, the insulation performance is also to be verified in the test specified in **Ch 16, 501. 6** of the Rules.

#### 6. Protection of insulation [See Rules]

In applying **413. 3 (4)** of the Rules, insulation materials are to be protected in accordance with the following requirements :

- (1) For insulation materials installed in hold spaces and tank covers, no fire protections and protections for mechanical damage may be provided except for cases where such are specially necessary. However, these insulation materials are to be applied with coating or subjected to surface treatment with aluminium foil, etc.
- (2) Insulation materials provided at exposed areas are to be protected by galvanized iron sheets or to be of the non-combustible insulation materials specified in the requirements in **Pt 8, Ch 3, 201.** of **Rules for the Classification of Steel Ships** applied with moisture-resistant coating. In case where the Society deems necessary, provision of steel covering may be requested as a protection against mechanical damage.
- (3) The coating materials to be applied on the surface of insulation materials are to comply with the requirements in **Pt 8, Ch 4, Sec 1** of **Rules for the Classification of Steel Ships** or equivalent.

Table 6.2 Properties of Insulation Material for Fuel Tank Types (2019)

No.	Ensuring items	Membrane	Type A/B independent tank	Type C independent tank	Note	
1	Compatibility with the fuel	○ <sup>1)</sup>	○ <sup>1)</sup>			
2	Solubility in the fuel	○ <sup>1)</sup>	○ <sup>1)</sup>			
3	Absorption of the fuel	○ <sup>1)</sup>	○ <sup>1)</sup>			
4	Shrinkage	○ <sup>1)</sup>	○ <sup>1)</sup>			
5	Aging	○	○ <sup>1)</sup>	□		
6	Closed cell content	△	△	△	applied only to closed cell material	
7	Density	○	○	○		
8	Mechanical properties	Bending strength	○	○	○	
		Compress. strength	○			
		Tensile strength	○	○	○	
		Shearing strength	○			
		Thermal expansion	○	○ <sup>2)</sup>	○ <sup>2)</sup>	
9	Abrasion	○				
10	Cohesion	△	△ <sup>1)</sup>	□	applied to cohered material	
11	Thermal conductivity	○	○	○		
12	Resistance to vibration	△	△ <sup>1)</sup>		refer to <b>413. 3 (7)</b> of the Rules	
13	Resistance to fire and flame spread	○	○	○		
14	Resistance to fatigue failure and crack propagation	△				
<p>Remarks</p> <p>○ : Items to be verified through verification test for properties.  △ : Items to be verified through verification test where deemed necessary depending on the insulation material.  □ : Items for which preparation of data on the properties is desirable.</p> <p>Notes :</p> <p>1) Necessary when the insulation material acts as spray shield specified in the requirements in <b>405. 1</b> of the Rules. In other cases, data on the properties is to be prepared.  2) Not generally required for fuel tanks where the design temperature exceeds -10°C.</p>						

Table 6.3 Test Items for Insulation Materials

Test items	Test methods
1. Compatibility with the fuel	Tensile, compress., shearing, bending test after dipping in the fuel (DIN 53428)
2. Solubility in the fuel	Changes in the size and weight of test specimen before and after dipping in the fuel (DIN 53428)
3. Absorption of the fuel	Comparison of weight of test specimen or test of water absorbing properties before and after dipping in the fuel (DIN 53428)
4. Shrinkage	ISO 2796, ASTM D 2126
5. Aging	-
6. Closed cell content	ISO 4590, ASTM D2856
7. Density	ISO 845, ASTM D1622
8. Mechanical properties	Bending (ISO 1209, ASTM C203, D790) Compress.(ASTM D695, D1621) Tensile (ISO1926, EN 1607, ASTM D638, D1623) Shearing (ISO 1922, ASTM C273) Thermal expansion (ASTM D696, E831)
9. Abrasion	-
10. Cohesion	ASTM D1623
11. Thermal conductivity	ISO 8302, KS L9016, ASTM C177, C518
12. Resistance to vibration	ISO 10055
13. Resistance to fire and flame spread	DIN 4102
14. Resistance to fatigue failure and crack propagation	-

#### 414. Construction processes (2019)

##### 1. Weld joint design

- (1) The "dome-to-shell connections" referred to in the requirements in **414. 1** (1) of the Rules are applicable to tanks with MARVS is 0.07 Mpa or below, and the connections mean ordinary fuel pipes or other penetrations of equivalent size sufficiently small when compared with the size of dome. **[See Rules]**
- (2) In welding of the penetrations referred to in the preceding (1) full penetration type welding may not be required, but are to have proper grooves. In this case, all the weld lines for penetrations of pipes with outside diameter exceeding 100 mm, and the partial weld lines for those with outside diameter of 100 mm or below, are to be subjected to non-destructive test as appropriate.
- (3) The "very small process pressure vessels" referred to in the requirements in **414. 1** (2) (A) of the Rules means pressure which are so small that it is difficult to remove their backing strip. **[See Rules]**

#### 415. Tank types (2019)

##### 1.Type A independent tanks **[See Rules]**

- (1) Design basis  
"Recognized standards" of the requirements in **415. 1** (1) (A) of the Rules means normally the requirements in **Pt 3, Ch 15 of Rules for the Classification of Steel Ships**.
- (2) Structural analysis  
(A) In applying **415. 1** (2) (A) of the Rules, the corrosion allowance may be reduced or may not be required in accordance with the requirements in **401. 7** of the Rules. In structures where the membrane or axial force due to internal pressure can not be neglected, the calculation equation specified in **Pt 3, Ch 15 of Rules for the Classification of Steel Ships** may be used after suitable modification.

- (B) In case where no corrosion allowance specified in **401. 7** of the Rules is required in accordance with the preceding (1), stiffeners may have section modulus more than 1/1.2 of one required in **Pt 3, Ch 15, Sec 2 of Rules for the Classification of Steel Ships**.
- (C) In applying **415. 1 (2) (B)** of the Rules, the following requirements are to be considered for loads and ship deflections.
- Ship deflections due to longitudinal bending moment in waves and longitudinal still water bending moment.
  - Ship deflections due to horizontal bending moment in waves and twisting moment, when necessary due to type of supporting structures.
  - Internal pressure specified in **409 3 (3) (A)** of the Rules.
- (3) Allowable stresses
- The "classical analysis procedures" referred to in the requirements in **415. 1 (3) (A)** of the Rules means the beam theory where the type of stress to be assessed is the combined stress of bending stress and axial stress.
  - In applying **415. 1 (3) (A)** of the Rules, the allowable stress for the equivalent stress  $\sigma_c$  when detailed stress calculations are made on primary members is to be as given in **Table 6.4**.

**Table 6.4 Allowable Stresses for the Primary Equivalent Stress (2019)**

Ferrite steels	Austenitic steels	Aluminium alloys
$0.79 R_e$	$0.84 R_e$	$0.79 R_e$
$0.53 R_m$	$0.42 R_m$	$0.42 R_m$
(Note) For each member, the smaller of the above values is to be used with $R_e$ and $R_m$ as specified in <b>412. 1 (1) (C)</b> of the Rules		

## 2. Type B independent tanks

### (1) Structural analysis [See Rules]

In applying **415. 2 (2)** of the Rules, the following requirements are to be complied with :

- The fuel tank structure is to be analyzed by three dimensional frame structural analysis method or finite element method. The model for the analysis is to include concerned hull structures and support construction considering ship deflections and local deflections of hull due to vertical, horizontal and twisting moments.
- The strength members of fuel tanks are to be computed in details by the finite element method. In case where compatible results can be obtained, however, the frame structural analysis method may be used in replacement therewith.
- In the preceding (A) and (B), dynamic loads necessary for the calculation of interactions between the hull and fuel tanks specified in **415. 2 (2) (B)** of the Rules are, as a rule, to be determined by long-term distribution in accordance with the requirements in **409. 4 (1) (A)** and **415. 2 (2) (C)** of the Rules where the most probable largest load in terms of the probability of occurrence as deemed appropriate by the Society is to be used. The dynamic stress ( $\sigma_{dyn}$ ) due to such loads are to be evaluated for their phase difference according to the requirements in **411. 2 (3)** of the Rules, and the total stress including dynamic stress is to be the sum of such dynamic stress and static stress ( $\sigma_{st}$ ). However, the load within fuel tanks may be considered as the internal pressure specified in the requirements in **409. 3 (3) (A) (e)** of the Rules by using the value of long-term distribution of acceleration computed by direct calculation according to the requirements in **409. 4 (1) (A)** and **415. 2 (2) (C)** of the Rules.
- The scantlings of fuel tank plates and stiffeners fitted to tank plates are to the satisfaction of the Society in consideration of the stress distribution and the mode of stress.
- In case where bulkheads are provided in fuel tanks, the scantlings of bulkhead plates and stiffeners fitted to the bulkhead plates are to the satisfaction of the Society.
- The strength members in fuel tanks are to be subjected to fatigue strength analysis for both the base metal and welded joints of high stress regions and stress concentration regions. S-N curves are to be plotted by experiment by the taking into account the following requirements :

- (a) Shape and size of test specimen
  - (b) Stress concentration and notch sensitivity
  - (c) Mode of stress
  - (d) Mean stress
  - (e) Welding conditions
  - (f) Ambient temperature
- (G) Relative to the design standards for the secondary barrier, the crack propagation analysis specified in the requirements in **415. 2 (2) (A)** of the Rules is to be carried out to verify that the assumed initial cracks would not reach the critical crack length in a period. The rate of fuel leakage is to be computed on the basis of the crack length obtained by this analysis.
- (H) It is to be verified that the fuel tank plates and associated structural members have sufficient strength against compressive buckling, torsional buckling of stiffeners, shearing buckling, and bending buckling of tripping brackets.
- (I) The accuracy in stress analysis is to be verified by model tank test or pressure measurements taken at time of pressure tests on a real ship in accordance with the requirements in **CH 16, 501. 5** of the Rules.

### 3. Type C independent tanks [See Rules]

- (1) Structural analysis
- (A) In applying **415. 3 (1)** of the Rules, for the scantlings, shapes and reinforcements of openings of fuel tanks against internal pressure in fuel tanks, the requirements for Class 1 pressure vessels in **Pt 5, Ch 5** of the Rules apply.
- (B) In applying **415. 3 (2) (C)** of the Rules,  $P_4$  among design external pressure  $P_0$  is to be the value computed by applying the requirements in **Pt 3, Ch 10, Sec 2**, in **Pt 3, Ch 16, Sec 2** and in **Pt 3, Ch 17, Sec 2** of **Rules for the Classification of Steel Ships** corresponding to the location of the tanks.

(2) Allowable stresses

In applying **415. 3 (3) (A)** of the Rules, the circumferential stresses at supports shall be calculated by a procedure acceptable to the Classification Society for a sufficient number of load cases.

(A) Permissible stresses in stiffening rings:

For horizontal cylindrical tanks made of C-Mn steel supported in saddles, the equivalent stress in the stiffening rings shall not exceed the following values if calculated using finite element method:

$$\sigma_e \leq \sigma_{all}$$

where:

$$\sigma_{all} = \min(0.57R_m; 0.85R_e)$$

$R_m$  and  $R_e$  : as defined in 412. 1 (1) (C) of the Rules

$$\sigma_e = \sqrt{(\sigma_n + \sigma_b)^2 + 3\tau^2}$$

$\sigma_e$  : equivalent stress (N/mm<sup>2</sup>)

$\sigma_n$  : nominal stress in the circumferential direction of the stiffening ring (N/mm<sup>2</sup>)

$\sigma_b$  : bending stress in the circumferential direction of the stiffening ring (N/mm<sup>2</sup>)

$\tau$  : shear stress in the stiffening ring (N/mm<sup>2</sup>)

Equivalent stress values  $\sigma_e$  is to be calculated over the full extent of the stiffening ring by a procedure acceptable to this Society, for a sufficient number of load cases as defined in **409. 3 (3) (H)**, **4 (1) (B)** and **5** of the Rules.

(B) The following assumptions are to be made for the stiffening rings:

- (a) The stiffening ring is to be considered as a circumferential beam formed by web, face plate, if any, and associated shell plating.

The effective width of the associated plating should be taken as:

(i) For cylindrical shells:

an effective width (mm) not greater than  $0.78 \sqrt{rt}$  on each side of the web.

A double plate, if any, may be included within that distance.

where:

$r$  = mean radius of the cylindrical shell (mm)

$t$  = shell thickness (mm)

(ii) For longitudinal bulkheads (in the case of lobe tanks):

the effective width (mm) is to be determined according to established standards.

A value of  $20 t_b$  on each side of the web may be taken as a guidance value.

where:

$t_b$  = bulkhead thickness (mm)

(b) The stiffening ring is to be loaded with circumferential forces, on each side of the ring, due to the shear stress, determined by the bi-dimensional shear flow theory from the shear force of the tank.

(C) For calculation of reaction forces at the supports, the following factors are to be taken into account:

(a) Elasticity of support material (intermediate layer of wood or similar material)

(b) Change in contact surface between tank and support, and of the relevant reactions, due to:

(i) thermal shrinkage of tank

(ii) elastic deformations of tank and support material

The final distribution of the reaction forces at the supports is not to show any tensile forces.

(D) The buckling strength of the stiffening rings is to be examined.

#### 4. Membrane tanks [See Rules]

(1) Design basis

In case where the design vapour pressure is made higher than 0.025 MPa in accordance with the provision to the requirements in **415. 4 (1) (D)** of the Rules, this vapour pressure is to be taken into account when model test specified in **Ch 16, 505. 1 (1)** of the Rules is conducted. In this case, special consideration is to be given to stress concentration for the welding and construction details of the adjacent hull structure.

(2) Design considerations

(A) In applying **415. 4 (2) (A)** of the Rules, in the assessments of plastic deformations and fatigue of the membrane and thermal insulation materials, all static and dynamic stresses and thermal stress specified in **409.** of the Rules

(B) In the assessments referred to in the preceding (A), verification is to be made through fatigue tests on a model combining the elements of the tank, second barrier, insulation structure and tank supporting structure considering the dimensional effects on real tank and the effects of dispersions in materials and fabrication accuracy as an integral part of the test specified in **Ch 16, 505. 1 (1)** of the Rules.

(3) Loads and load combinations

The assessments of collapse of the membrane referred to in the requirements of **415. 4 (3)** of the Rules are to be made in accordance with the following requirements :

(A) For overpressure and negative pressure in the interbarrier space, collapse test is to be conducted on a prototype model of the membrane to verify its ultimate strength.

(B) For sloshing loads, impact load experiment is to be carried out on a prototype model of the membrane to verify its strength when the Society considers necessary.

(4) Structural analyses

In applying **415. 4 (4) (B)** of the Rules, the hull structure adjacent to membrane tanks is to comply with the requirements in **Pt 3, Ch 15 of Rules for the Classification of Steel Ships** and, in addition, the stress in the hull structure is to be restricted in consideration of the structural strength of membrane tanks, if necessary. The allowable stresses of the membrane, membrane supporting structures and insulation materials are to be determined in each case according to the mechanical properties of materials, records of construction, product specifications and levels of product quality control practice.

## Section 7 Pressure Relief System

### 702. Pressure relief systems for liquefied gas fuel tanks

1. In applying **702. 3** of this Rules, sizing of pressure relief device is to be in accordance with the following requirements : **[See Rules]**

- (1) The combined relieving capacity of the pressure relief devices for interbarrier spaces surrounding type A independent cargo tanks where the insulation is fitted to the cargo tanks may be determined by the following formula :

$$Q_{sa} = 3.4A_c \frac{\rho}{\rho_v} \sqrt{h} \quad (\text{m}^3/\text{s})$$

where:

$Q_{sa}$  : minimum required discharge rate of air at standard conditions of 273K and 0.1013 MPa

$A_c$  : design crack opening area ( $\text{m}^2$ ),  $\pi\delta l/4$

$t$  : thickness of tank bottom plating (m)

$l$  : design crack length equal to the diagonal of the largest plate panel of the tank bottom (m), see Fig **6.2** of the Guidance

$h$  : maximum liquid height above tank bottom plus 10·MARVS (m)

$\rho$  : density of product liquid phase at the set pressure of the interbarrier space relief device ( $\text{kg}/\text{m}^3$ )

$\rho_v$  : density of product vapour phase at the set pressure of the interbarrier space relief device and a temperature of 273 K ( $\text{kg}/\text{m}^3$ )

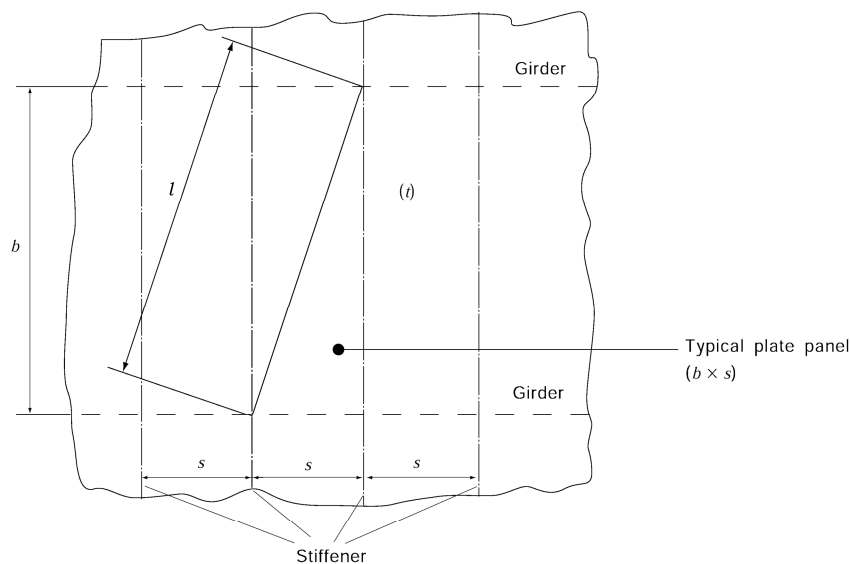

Fig. 7.5.30 The Example Size of Tank Bottom Plate

Fig 6.2 The example size of tank bottom plate

- (2) The relieving capacity of pressure relief devices of interbarrier spaces surrounding type B independent cargo tanks may be determined on the basis of the preceding (1). However, the leakage rate is to be determined in accordance with **405. 2** of the Rules.
- (3) The relieving capacity of pressure relief devices of interbarrier spaces of membrane tanks is to be evaluated on the basis of specific membrane tank design.

**703. Sizing of pressure relieving system**

1. In applying **703. 1 (1) (B)** of this Rules, For prismatic tanks: **[See Rules]**

(1)  $L_{min}$ , for non-tapered tanks, is the smaller of the horizontal dimensions of the flat bottom of the tank. For tapered tanks, as would be used for the forward tank,  $L_{min}$  is the smaller of the length and the average width.

(2) For prismatic tanks whose distance between the flat bottom of the tank and bottom of the hold space is equal to or less than  $L_{min}/10$ :

$A$  = external surface area minus flat bottom surface area.

(3) For prismatic tanks whose distance between the flat bottom of the tank and bottom of the hold space is greater than  $L_{min}/10$ :

$A$  = external surface area

**Section 8 Loading Limit for Liquefied Gas Fuel Tanks (2019)****801. Loading Limits (2019) [See Rules]**

1. In applying **801. 2** of the Rules, storage tank loading limits higher than calculated using reference temperature is understood to be an alternative to **801. 1** of the Rules and should only be applicable when the calculated loading limit using the formulae in **801. 1** of the Rules gives a lower value than 95%.

**Section 9 Maintaining of fuel storage condition****901. Control of tank pressure and temperature**

1. In applying **901. 1** of this Rules, liquefied gas fuel tanks' pressure and temperature should be controlled and maintained within the design range at all times including after activation of the safety system required in **Ch 15. 301. 2.** for a period of minimum 15 days. The activation of the safety system alone is not deemed as an emergency situation. **[See Rules]**

**903. Reliquefaction systems (2019) [See Rules]**

1. If the cooling medium for heat exchanger is returned into machinery spaces, provisions are to be made to detect and alarm the presence of fuel in the medium. Any vent outlet is to be in a safe position and fitted with an effective flame screen of an approved type.↓

## CHAPTER 7 MATERIAL AND GENERAL PIPE DESIGN

### Section 3 Pipe design

#### 301. General

1. In applying **301. 1** of this Rules, standard recognized by the Society means **EN ISO 14726**.  
[See Rules]

#### 302. Wall thickness

1. In applying **302. 1** of this Rules, the corrosion allowance is to be in accordance with the following (1) and (2): [See Rules]
  - (1) For LNG fuel, the corrosion allowance is to be 0.3 mm for carbon-manganese steel and 0 mm for stainless steel and aluminium alloys. Where effective corrosion control are taken for the interior of carbon-manganese steel pipes, the corrosion allowance may be 0.15 mm.
  - (2) In addition to the preceding (2), for carbon-manganese steel pipes arranged on open deck without any effective external corrosion control means, 1.2 mm is to be added to the required corrosion allowance.
2. In applying **302. 2** of this Rules, the "minimum wall thickness is to be in accordance with recognized standards" means the value corresponding to Schedule 40 of KS SPPS for carbon-manganese steel, and the value corresponding to Schedule 10 S for stainless steel. However, for steel pipes provided with effective corrosion control or those not arranged under corrosive environment, the value may be reduced to the extent acceptable to the Society with a limitation of 1 mm. Further, the value for pipes in cargo tanks and pipes having open ends may also be reduced to the extent acceptable to the Society. [See Rules]

#### 303. Design condition

1. In applying **303. 1** of this Rules, the following (1) and (2) are applied. [See Rules]
  - (1) In applying **303. 1** of this Rules, lower values of ambient temperature 45 °C may be accepted by the Society for ships operating in restricted areas. Conversely, higher values of ambient temperature may be required.
  - (2) In applying **303.** of this Rules, for ships on voyages of restricted duration,  $P_0$  may be calculated based on the actual pressure rise during the voyage and account may be taken of any thermal insulation of the tank. Reference is made to the Application of amendments to gas carrier codes concerning type C tank loading limits (SIGTTO/IACS).

#### 306. Piping fabrication and joining details [See Rules]

1. Valves, flanges and other fittings are to comply with the requirements of recognized standards for their type and size, and the requirements in **Pt 5, Ch 6, 103. & 104.** of **Rules for the classification of steel ships**.

## Section 4 Materials

### 401. Metallic materials

1. For the purpose of the requirements in **Table 7.1** of this Rules, the following requirements are to be complied with : **[See Rules]**
  - (1) The use of the longitudinally or spirally welded pipes given in the Note (1) of the Table is to be in accordance with the relevant requirements in **Pt 2, Ch 1, Sec 4 of Rules for the classification of steel ships**.
  - (2) Fittings of type C independent tanks and process pressure vessels with the design pressure not exceeding 3.0MPa and design temperature of 0°C or more and nominal diameter less than 100A given in Note (1) may comply with the requirements of KS or other standards as deemed appropriate by the Society.
  - (3) The controlled rolling as a substitution for normalizing given in Note (4) may be of the temperature controlled rolling or Thermo-Mechanical Controlled Processing (TMCP). Also, the controlled rolling as a substitution for tempering and quenching may be of TMCP.
2. The controlled rolling as a substitution for normalizing or tempering and quenching given in Note (4) of **Table 7.2** of this Rules may be of TMCP. **[See Rules]**
3. For the purpose of the requirements in **Table 7.3** of this Rules, the following requirements are to be complied with : **[See Rules]**
  - (1) For the purpose of the requirements in Note (2) of the Table, aluminium alloy of 5083, austenitic stainless steel, 36 % nickel steel and 9 % nickel steel may be used at the design temperature up to 196°C.
  - (2) For the purpose of the requirements in Note (5) of the Table, the chemical composition limit of a material, if the material specified in **Pt 2 of Rules for the classification of steel ships**, is to be in accordance with the relevant requirements in **Pt 2, Ch 1 of Rules for the classification of steel ships**.
  - (3) For the purpose of the requirements in Note (9) of the Table, the omission of the impact test given in Note (9) of the Table may generally be accepted for the austenitic steel of the type referred to in the Table.
4. For the purpose of the requirements in **Table 7.4** of this Rules, the following requirements are to be complied with : **[See Rules]**
  - (1) The use of vertically or spirally welded pipes given in Note (1) of the Table is to be in accordance with the requirements in the preceding (1) (A).
  - (2) The requirements for forgings and castings given in Note (2) of the Table are to be in accordance with the relevant requirements in **Pt 2, Ch 1 of Rules for the classification of steel ships** if specified.
  - (3) For the design temperature given in Note (3) of the Table lower than -165 °C, the provision in the preceding **3. (1)** are to apply.
  - (4) The chemical composition limit given in Note (5) of the Table is to be in accordance with the requirements in the preceding **3. (2)**
  - (5) The omission of the impact test given in Note (8) of this Table are to be in accordance with the requirements in the preceding **3. (3)**
5. Where reference is made to hull structural steels, the requirements of **Pt 2, Ch 1, 301. of Rules for the classification of steel ships** for appropriate grades apply. **[See Rules]** ↓

---

## CHAPTER 8 BUNKERING

### Section 3 Bunkering Station

#### 301. General requirements

1. In applying **301. 1** of this Rules, the special consideration is to be as a minimum include, but not be restricted to, the following design features: **[See Rules]**
  - (1) Segregation towards other areas on the ship
  - (2) Hazardous area plans for the ship
  - (3) Requirements for forced ventilation
  - (4) Requirements for leakage detection (e.g. gas detection and low temperature detection)
  - (5) Safety actions related to leakage detection (e.g. gas detection and low temperature detection)
  - (6) Access to bunkering station from non-hazardous areas through airlocks
  - (7) Monitoring of bunkering station by direct line of sight or by CCTV.

### Section 5 Bunkering System

#### 501. Bunkering system (2019) [See Rules]

##### 1. Tests of bunkering equipment

For the bunkering equipment, the requirements specified in **Pt 7, Ch 5, Annex 7A-3 of Rules for the classification of steel ships.** ↓

---

## CHAPTER 9 FUEL SUPPLY TO CONSUMERS

### Section 4 Safety Functions of Gas Supply System

#### 401. Safety functions of gas supply system [See Rules]

1. In applying **401. 1** of this Rules, normal operation is when gas is supplied to consumers and during bunkering operations.
2. In applying **401. 1** of this Rules, with regard to “shut off”, shutdown is to be time delayed to prevent shutdown due to transient load variations.

### Section 5 Fuel Distribution Outside of Machinery Space

#### 501. Fuel distribution outside of machinery space

1. In applying **501. 1** of this Rules, in cases where double wall piping with vacuum used as secondary enclosure is adopted as other solutions, appropriate means capable of detecting loss of vacuum are to be provided. [See Rules]

### Section 6 Fuel Supply to Consumers in Gas-safe Machinery Spaces

#### 601. Fuel supply to consumers in gas-safe machinery spaces

1. In applying **601. 1** of this Rules, in cases where double wall piping with vacuum used as secondary enclosure is adopted as other solutions, appropriate means capable of detecting loss of vacuum are to be provided. Gas detector may be omitted on the double wall piping with vacuum used as secondary enclosure. [See Rules]
2. In applying **601. 2** of this Rules, if gas is supplied into the air inlet directly on each individual cylinder during air intake to the cylinder on a low pressure engine, such that a single failure will not lead to release of fuel gas into the machinery space, double ducting may be omitted on the air inlet pipe. [See Rules] ↓

---

---

## CHAPTER 10 POWER GENERATION INCLUDING PROPULSION AND OTHER GAS CONSUMER

### Section 3 Internal Combustion Engines of Piston Type

#### 301. General

1. In applying **301. 6** of this Rules, an example of means provided to monitor and detect poor combustion or misfiring may be sensors fitted to monitor the exhaust gas temperature and the status of knocking. **[See Rules]** ↓

## CHAPTER 11 FIRE SAFETY

### Section 3 Fire Protection

#### 301. Fire protection

1. In applying **301. 1** of this Rules, fire protection means structural fire protection, not including means of escape.
2. In applying **301. 1** of this Rules, enclosed spaces containing equipment for fuel preparation such as pumps or compressors or other potential ignition sources are to be provided with a fixed fire-extinguishing system complying with **Pt 8, Ch 8, 301. 1** of **Rules for the classification of steel ships**, the FSS Code and taking into account the necessary concentrations/application rate required for extinguishing gas fires. **[See Rules]**
3. In applying **301. 3** of this Rules, the following “other rooms with high fire risk” is to be as a minimum be considered, but not be restricted to: **[See Rules]**
  - (1) Cargo spaces except:
    - (A) cargo tanks for liquids with FP above 60 °C
    - (B) the carriage of ore, coal, grain, unseasoned timber, non-combustible cargoes or cargoes which, in the opinion of the Society, constitute a low fire risk complying with **Pt 8, Ch 8, 601. 4** of **Rules for the classification of steel ships**.
  - (2) Vehicle, Ro-Ro and special category spaces
  - (3) Service spaces (high risk): Galleys, pantries containing cooking appliances, saunas, paint lockers and store-rooms having areas of 4 m<sup>2</sup> or more, spaces for the storage of flammable liquids and workshops other than those forming part of the machinery space.
  - (4) “Accommodation spaces of greater fire risk for ships carrying more than 36 passengers: saunas, sale shops, barber shops and beauty parlours and public spaces containing furniture and furnishings of other than restricted fire risk and having a deck area of 50m<sup>2</sup> or more.” ∩

## CHAPTER 12 EXPLOSION PREVENTION

### Section 4 Area Classification

#### 401. Area classification [See Rules]

1. In applying **401. 2** of this Rules, electrical installations are to be complied with applicable requirements of **Pt 7, Ch 5** of **Rules for the classification of steel ships**.
2. In applying **401. 2** of this Rules, area classification is to refer to **IEC standard 60092-502** and **IEC 60079-10-1**.

### Section 5 Hazardous Area Zones

#### 502. Zone “1” [See Rules]

1. Measuring instruments and electrical equipment are to be capable of being used in the hazardous area zone 1.
2. Fuel storage hold spaces for type C tanks are normally not considered as hazardous area zone 1. For the purposes of hazardous area classification, fuel storage hold spaces containing Type C tanks with all potential leakage sources in a tank connection space and having no access to any hazardous area, is to be considered non-hazardous. Where the fuel storage hold spaces include potential leak sources, e.g. tank connections, they is to be considered hazardous area zone 1. Where the fuel storage hold spaces include bolted access to the tank connection space, they is to be considered hazardous area zone 2. (2019) [See Rules]
3. In applying **3** of this Rules, any fuel tank outlet, gas or vapour outlet means, for example, all areas within 3 m of fuel tank hatches, ullage openings or sounding pipes for fuel tanks located on open deck and gas vapour outlets.
4. In addition to the zones defined in **502.** of this Rules, examples of hazardous area zone 1 include, but are not limited to, the following: (2019)
  - (1) enclosures or compartments containing gas regulating and/or block and bleed valves;
  - (2) areas on open deck or semi-enclosed spaces on deck, with 3 m of ventilation outlets of spaces:
    - (A) tank connection spaces
    - (B) fuel storage hold spaces
    - (C) interbarrier spaces
    - (D) enclosed or semi-enclosed spaces in which pipes containing fuel are located
    - (E) enclosures or compartments defined in (1)
  - (3) areas on open deck or semi-enclosed spaces on open deck above and in the vicinity of any vent outlet intended for the passage of large volumes of gas or vapour, within a vertical cylinder of unlimited height and 6 m radius centered upon the centre of the outlet and within a hemisphere of 6 m radius below the outlet;
  - (4) in applying (3), areas may be reduced up to 3 m based on a specific gas dispersion analysis

#### 503. Zone “2”

1. Measuring instruments and electrical equipment are to be capable of being used in the hazardous area zone 2.
2. In addition to the zones defined in **503.** of this Rules, examples of hazardous area zone 1 include, but are not limited to, the following: (2019)
  - (1) airlocks protecting a non-hazardous area from hazardous area zone 1.
  - (2) areas 4 m beyond the areas defined in **502. 4 (3)** of this **Guidance**.
  - (3) in applying (2), areas may be reduced up to 1.5 m based on a specific gas dispersion analysis  
↓

## CHAPTER 13 VENTILATION

### Section 3 General Requirements

#### 303. Design of ventilation fans serving spaces containing gas sources [See Rules]

1. In applying 303. of this Rules, protection screens of not more than 13 mm square mesh are to be fitted in the ventilation openings on the open deck of the ducts in which fans are fitted.

#### 309. Non-hazardous spaces with entry openings to a hazardous area

1. In applying 309. 2 (2) of this Rules, standard recognized by the Society means those specified in table 5 of IEC 60092-502. [See Rules]

**Table 13.1 Protective measures to be taken in the event of failure of pressurization (IEC 60092-502 Table 5)**

Classification of the space*	Electrical equipment installed		
	Equipment suitable for use in zone 1	Equipment suitable for use in zone 2	Equipment not protected for any hazardous area
Zone 1	No action necessary	<ul style="list-style-type: none"> <li>- Suitable alarm (visible and audible)</li> <li>- Immediate action to restore pressurisation</li> <li>- Programmed disconnection of power supplies if the pressurisation cannot be restored for an extended period or if the concentration of flammable gas rises to a dangerous level</li> </ul>	<ul style="list-style-type: none"> <li>- Suitable alarm (visible and audible)</li> <li>- Immediate action to restore pressurisation</li> <li>- Automatic interruption of the power supplies as rapidly as practicable within a prescribed delay time with regard to the needs of a programmed shut-down</li> </ul>
Zone 1	No action necessary	No action necessary	<ul style="list-style-type: none"> <li>- Suitable alarm (visible and audible)</li> <li>- Immediate action to restore pressurisation</li> <li>- Programmed disconnection of power supplies if the pressurisation cannot be restored for an extended period or if the concentration of flammable gas rises to a dangerous level</li> </ul>
(NOTES)			
For * in the Table, classification of the space or area into which the opening lead			

### Section 5 Machinery Spaces

#### 501. Regulations for machinery Spaces

1. In applying 501. 1 of this Rules, spaces enclosed in the boundaries of machinery spaces (such as purifier's room, engine-room workshops and stores) are considered an integral part of machinery spaces containing gas-fuelled consumers and, therefore, their ventilation system does not need to be independent of the one of machinery spaces. [See Rules]
2. In applying 501. 3 of this Rules, standard recognized by the Society means those specified in table 5 of IEC 60079-10-1. [See Rules]

---

---

## Section 8 Ducts and Double Pipes

### 801. Regulations for ducts and double pipes

1. In applying **801. 2** of this Rules, double piping and gas valve unit spaces in gas safe engine-rooms are considered an integral part of the fuel supply systems and, therefore, their ventilation system does not need to be independent of other fuel supply ventilation systems provided such fuel supply systems contain only gaseous fuel. **[See Rules]**
2. In applying **801. 3** of this Rules, the ventilation inlet for the double wall piping or duct should always be located in a non-hazardous area in open air away from ignition sources. **[See Rules]** ↓

---

## CHAPTER 14 ELECTRICAL INSTALLATIONS

### Section 3 General Requirements

#### 301. General requirements

1. In applying **301. 4** of this Rules, standard recognized by the Society means **IEC 60812**.  
[See Rules] ↓

## CHAPTER 15 CONTROL, MONITORING AND SAFETY SYSTEMS

### Section 3 General Requirements

#### 301. General requirements

1. In applying **301. 2** of this Rules, the level indicator is understood to be required for the purposes of indicating an alarm status only; a level switch (float switch) is an instrument example considered to meet this requirement. **[See Rules]**

### Section 4 Bunkering and Liquefied Gas Fuel Tank Monitoring

#### 402. Overflow control (2018) **[See Rules]**

1. In applying **402. 3** of this Rules, the expression “each dry-docking” refers to:
  - (1) the survey of the outside of the ship’s bottom required for the renewal of the Cargo Ship Safety Construction Certificate and or the Cargo Ship Safety Certificate, for cargo ships.
  - (2) the survey of the outside of the ship’s bottom to be carried out every 60 months according to IMO Resolution A.1104(29, paragraphs 5.10.1 and 5.10.2), for passenger ships.

### Section 8 Gas Detection

#### 801. Gas detection

1. In applying **801. 1** of this Rules, standard recognized by the Society means **IEC 60079-29-1**. **[See Rules]**

### Section 10 Ventilation

#### 1001. Ventilation

1. In applying **1001. 1** of this Rules, acceptable means to confirm that the ventilation system has the “required ventilating capacity” in operation are, but not limited to: (2019)
  - (1) Monitoring of the ventilation electric motor or fan operation combined with underpressure indication ; or
  - (2) Monitoring of the ventilation electric motor or fan operation combined with ventilation flow indication ; or
  - (3) Monitoring of ventilation flow rate to indicate that the required air flow rate is established.⤵

## CHAPTER 16 MANUFACTURE, WORKMANSHIP AND TESTING

### Section 1 General

#### 101. General [See Rules]

1. In applying **Ch 16** of this Rules, equipment used for low-flashpoint fuel supply is to be in accordance with relevant requirement **Annex 1** in addition to this Rules.

### Section 2 General test regulations and specifications

#### 201. Tensile test [See Rules]

1. In applying **201. 1** of the Rules, the required values of tensile strength, yield stress and elongation of a material are to be in accordance with the requirement in **Pt 2** of **Rules for the classification of steel ships**.

#### 202. Toughness test

1. In applying **201. 1** of this Rules, to be in accordance with Recognized Standard means to refer to **Pt 2, Ch 1, 202. 3 (4)** of **Rules for the classification of steel ships**. [See Rules]
2. For the purpose of the requirements in **202. 2** of the Rules, in the case where the material thickness is 40mm or below, the Charpy V-notch impact test specimens are to be cut with their edge within 2 mm from the “as rolled” surface with their longitudinal axes either parallel or transverse to the final direction of rolling of the material as shown in **Fig 16.1**. (2019)

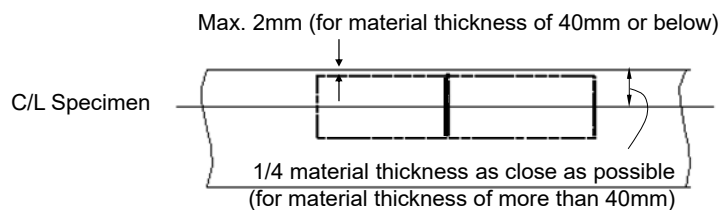

**Fig 16.1 Sampling position of Charpy V-notch impact test specimens(Base metal)**

3. In application to **202. 3** of the Rules, the position of the specimens is to be in accordance with **Fig 16.2**. (2019)

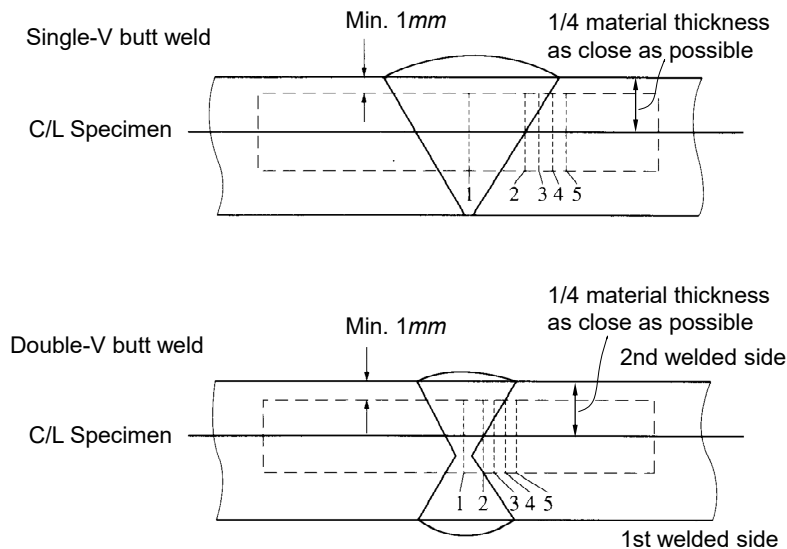

**Fig 16.2 Sampling position of Charpy V-notch impact test specimens (Weld)**

4. In application to **202. 4** of the Rules, the re-testing of Charpy V-notch impact test specimens is to be in accordance with **Pt 2, Ch 1, 109.** of **Rules for the classification of steel ships.** (2019)

### Section 3 Welding of metallic materials and non-destructive testing for the fuel containment system

#### 301. General [See Rules]

1. The requirements in **Sec 3** of the Rules apply to independent tanks, process pressure vessels and piping. The requirements on membrane tanks, are to the satisfaction of the Society depending on the structural type of the tank.
2. In applying **303.** of the Rules, the following requirements (1) and (2) are to be complied with.
  - (1) The impact test may generally be omitted for austenitic stainless steels of types given in **Table 7.3** and **Table 7.4** of the Rules.
  - (2) The impact test may generally be omitted for aluminum alloys of 5083 and welding material of 5183.
  - (3) Welding procedure tests for secondary barriers are to be in accordance with **Pt 2, Ch 2, Sec 4** of **Rules for the Classification of Steel Ships.** (2019)

#### 303. Welding procedure tests for fuel tanks and process pressure vessels

1. In application to **303. 3** of the Rules, radiographic or ultrasonic testing may be performed at the option of the Society.
2. For the purpose of the requirements in **303. 4** of the Rules the following requirements are to be complied with :
  - (1) Longitudinal bend tests which are required in lieu of transverse bend tests in the case where the base material and weld metal have different strength level specified in **303. 4 (3)** of the Rules are to be in accordance with the requirements in **Pt 2, Ch 2, 404.** of **Rules for the Classification of Steel Ships.**
  - (2) For type C independent tanks and process pressure vessels, macroscopic and microscopic examinations and hardness tests are to be carried out according to the requirements of **303. 4 (5)** of the Rules. For other independent tanks, macroscopic examinations are to be carried out according to the requirements in **Pt 2, Ch 2, Sec 4** of **Rules for the Classification of Steel Ships.**

3. In applying **605. 3 (5)** of the Rules, the welding procedure qualification test are also to comply with the relevant requirements in **Pt 2, Ch 2, Sec 4.** and **Pt 5, Ch 5, Sec 4** of **Rules for the Classification of Steel Ships.**
4. In applying **303. 5 (1)** of the Rules, the transverse tensile strength of weld metal which has lower tensile strength than that of the parent metal, e.g. in the case of 9% nickel steel, is to comply with the requirements in **Pt 2, Ch 2, 404. 5** of **Rules for the Classification of Steel Ships.**
5. In applying **303. 5 (2)** of the Rules, bend tests are also to comply with the requirements in **Pt 2, Ch 2, 404. 6** of **Rules for the Classification of Steel Ships.** In case where the base metal is of RLP9 specified in **Pt 2, Ch 1** of **Rules for the Classification of Steel Ships,** bend tests may be omitted.
6. In applying **303. 5 (3)** of the Rules, the test temperature of impact tests may be determined in accordance with the requirements in **Ch 6, 413. 2 (1).**

#### **304. Welding procedure tests for piping [See Rules]**

1. Welding procedure qualification tests for pipes are also to be in accordance with the relevant requirements in **Pt 2, Ch 2** of **Rules for the classification of steel ships.**

#### **305. Production weld tests [See Rules]**

1. Production weld tests are to be in accordance with the requirements specified in **Pt 2, Ch 2, 103.** of the Guidance relating to **Rules for the classification of steel ships.**
2. For the purpose of the requirements in **305. 1** of the Rules, the number of test specimens for production weld tests of secondary barriers may be reduced to the extent as deemed appropriate by the Society considering the experience of same welding procedures in past, workmanship and quality control. In general, intervals of production weld tests for secondary barriers may be approximately 200 m of butt weld joints and the tests are to be representative of each welding position. Test requirements are to be in accordance with **303. 5** of the Rules.
3. For the purpose of the requirements in **305. 5** of the Rules, production weld tests for membrane tanks are left to the discretion of the Society depending on the construction system of the tank.

#### **306. Non-destructive testing [See Rules]**

1. In applying **306. 1** of this Rules, The following requirements (1) through (4) are to apply as the testing procedures.
  - (1) For radiographic tests, the test may be in accordance with the requirements in KS B 0845, ISO 2437, ISO 2504 and ISO/R1027 where the acceptance criteria are to be KS Grade 2 or higher. In the case of KS Grade 3, acceptance is left to the discretion of the Society in consideration of the importancy of the structural members and nature of defects, etc.
  - (2) For ultrasonic tests, the requirements in KS D 0250 apply correspondingly.
  - (3) For magnetic particle test, the requirements in KS D 0213 apply correspondingly.
  - (4) For dye penetrant tests, the requirements in KS B 0816 apply correspondingly.
2. In applying **306. 1** of this Rules, where ultrasonic tests are performed as a substitution for radiographic tests, at least 10% of the whole testing objects are to be subjected to radiographic tests.
3. In applying **306. 2** of the Rules, for the non-destructive tests for the remaining welds of tank plates of type A and B independent tanks other than butt welds, fillet welds of highly stressed parts of main structural members of fuel tanks are to be examined magnetic particle or dye penetrant tests given in **1.** Butt welds of highly stressed parts of main structural members such as face plates of girders are to be subjected to radiographic test given in **1.**
4. In applying **306. 7** of this Rules, the radio-graphic tests of secondary barriers where the hull structure acts as the secondary barrier are to be performed for the double bottom tank top platings and bulkhead platings in accordance with the requirements for shell platings of ordinary ships specified in **Pt 2, Ch 2, 309.** of **Rules for the classification of steel ships.**

## Section 4 Other Regulations for Construction in Metallic Materials (2019)

### 404. Membrane Tanks [See Rules]

1. In applying **404.** of the Rules, quality assurance procedure, welding control, design details, quality control of materials, construction method, inspection and standards of production testing of components for membrane tanks are to be developed during the prototype scaled model test specified in **Ch 16, 505. 1 (1)** of the Rules or another prototype test separately conducted for development of production procedure, and their effectiveness is to be verified. The relevant data is to be noted in the construction procedure manual for fuel tanks including the insulation construction of membrane tanks.
2. The construction procedure manual referred to in the preceding **1** is to be approved by the Society after being verified through prototype scaled model test.

## Section 5 Testing (2019)

### 501. Testing and Inspections during Construction

#### 1. Structural Test and Tightness test for fuel tanks [See Rules]

In case where leakage of fuel tanks can not be inspected in the hydraulic test or hydrostatic-hydro-pneumatic test according to the requirements in **501. 2** of the Rules, the tightness test of fuel tanks is to be conducted separately. This test is to be of the airtightness test conducted at a pressure of MARVS or more of the fuel tank.

#### 2. Stress measurements instrumentation of type B independent tanks [See Rules]

In applying **501. 5** of the Rules, in case where stress measurements of the fuel tank previously built which can be regarded as the tank of the same design manufactured at the same shipyard had resulted in good agreement with design stress levels, provision of instrumentation of independent tanks stress levels for tanks subsequently built may be omitted.

#### 3. Gas-trial and fuel full loading test [See Rules]

(1) In accordance with the requirements in **501. 6** and **702. 5** of the Rules, the following tests are to be conducted in the attendance of the Surveyor to verify the performance of the fuel containment installations and fuel handling equipment :

##### (A) Gas-trial

On items given in **Table 16.1**, tests are to be conducted to verify the performance of the fuel containment system fuel handling equipment and instrumentation using a suitable quantity of the fuel after the completion of all the construction work. However, for fuel tanks which do not require either cool-down operations or the fuel pressure/temperature controls specified in **Ch 6, 901. 1** of the Rules, omission of this test may be accepted if substitution is made by the operating test with the substituting medium to verify the performance of equipments specified in item 5 and 6 of **Table 16.1**, except for the case where the tank is of the first fuel tank manufactured by the manufacturer of fuel tanks.

##### (B) Fuel full loading test

Where deemed necessary by the Society, tests are to be conducted after completion of all the construction work to verify that the fuel containment installations, fuel handling equipment and instrumentation satisfy the design conditions under the fully loaded condition of fuel.

- (2) The kinds of real liquid fuel and gas used in the gas-trial and fuel full loading test specified in the preceding (1) are to be such that reproduction of the most severe conditions of those design conditions of the fuel containment system, the transfer installations, the reliquefaction system, etc. In addition, the verification relative to design temperatures is to be made by reproducing the condition that the fuel on the basis of which design temperature has been determined is cooled down as close to the design temperature as practicable.
- (3) The quantities of the real fuel and vapour used in the gas-trial and fuel full loading test referred to in the preceding (1) are to be sufficient to conducting the tests specified in (1).
- (4) The fuel full loading test to capacity specified in the preceding (1) (B) may be conducted simultaneously with the gas-trial indicated in the preceding (1) (A).

Table 16.1 Test Items at the Gas Trial (2019)

Test item	◎ : Attendance of the Surveyor ○ : Submission of the record	Inspection equipment	Survey item
1. Drying test	○	· Inert gas generator (IGS)	· Dew point · Change of dryness in fuel tanks and hold spaces
2. Inerting test	○	· Inert gas generator	· Operation of the inert gas generator · Measuring of atmosphere in fuel tanks
3. Inert gas purge test using fuel vapour	○	· Fuel vapourizer · Compressor	· Change of O <sub>2</sub> /temperature of fuel vapour in fuel tanks · Quantity of fuel vapour (or liquid) supply · Capacity of the vapourizer · Capacity of the compressor
4. Cool-down test	◎/○	· Spray pump · Compressor · Fuel piping · Temperature indicators for fuel tank · Spray piping	· Temperature curve of fuel tanks · Inspection of hold spaces/condition of insulation of tanks <sup>1)</sup> (after cool-down) · Cooling condition of spray piping·Cooling condition of fuel piping · Capacity of spray pump · Fuel consumption · Capacity of compressor (property of return gas) · Temperature/pressure in fuel tank · Shrinkage of fuel tank <sup>2)</sup>
5. Loading test of fuel liquid	◎/○	· Compressor · Fuel piping related for loading · Level gauge/temperature indicator	· Temperature/pressure level in fuel tanks · Temperature/pressure in hold spaces · Temperature/pressure of fuel liquid/gas at manifolds · Service condition of fuel piping
6. Operation test of fuel pump	◎/○	· All fuel pumps	· Discharge pressure/current of fuel pumps · Liquid level/pressure in fuel tanks · Stripping
7. Operation test of pressure/temperature control system	◎/○	· Depend on the type of controls	· Depend on the type of controls
Notes :			
1) The Society may approve omission in consideration of the quality control status and manufacturing records of insulation materials.			
2) To be verified only in case of independent tanks.			

#### 4. Cold spot inspection [See Rules]

- (1) The cold spot inspection of fuel tanks specified in **501. 7** of the Rules is to be carried out during the fuel full loading test to capacity specified in **3 (1)** for the membrane tank, internal insulation tank, and when necessary, independent tank.

**502. Independent Tank Type A [See Rules]**

**1. Hydrostatic or hydropneumatic test for independent tank**

(1) In applying 502. of the Rules, the hydrostatic or hydropneumatic test of fuel tanks is to be conducted by simulating the actual load conditions (static load + dynamic load) in accordance with the following requirements :

(A) Test of fuel tanks

Hydrostatic-hydropneumatic test is to simulate the static pressure of fuel, acceleration by ship motions and internal pressure including the vapour pressure by water head and pneumatic pressure. (See Fig 16.3, Fig 16.4 and Fig 16.5)

(B) Load test of supporting structures

Hydraulic test is to simulate the fuel weight and the load created by the acceleration due to ship motions solely by the weight of water. (See Fig 16.6)

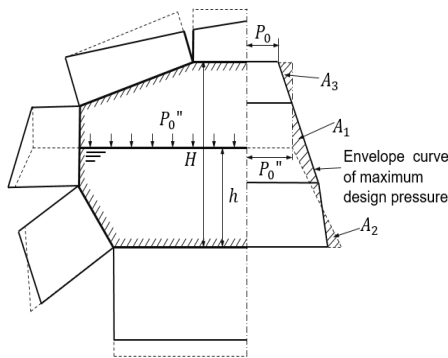

**Fig 16.3 Simulating the Internal Pressure Distribution of Rectangular Tank**

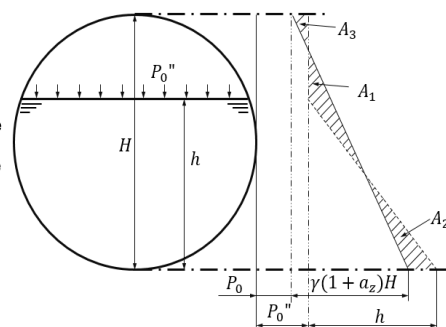

**Fig 16.4 Simulating the Internal Pressure Distribution of Spherical Tank**

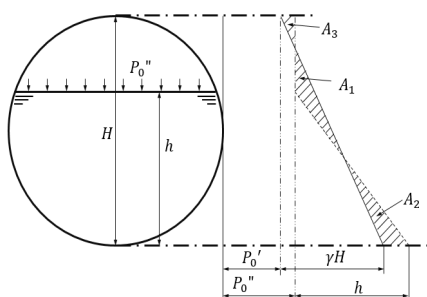

**Fig 16.5 Simulating the Internal Pressure Distribution at Pressure Discharge**

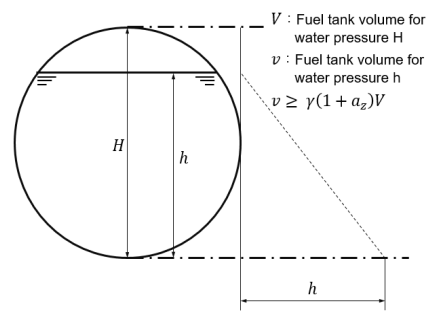

**Fig 16.6 Simulating the Loading Condition of Support Structure**

\* Explanatory notes on symbols in Fig 16.3 to Fig 16.6.

----- : maximum loading condition which is predicted to actually encounter

... : pressure testing condition simulating as far as practicable ( $P_0''$  and  $h$  are to be chosen so that  $P_0'' > P_0$  or  $P_0'' > P_0'$  and  $A_2 + A_3 > A_1$  as far as practicable)

$H$  : depth of tank

$h$  : water head

$\gamma$  : specific gravity of fuel

$a_z$  : maximum vertical acceleration (non-dimensional)

$P_0$  : design vapour pressure at ordinary passage

$P_0'$  : design vapour pressure during pressurized unloading in port

$P_0$  : air pressure

(2) All tests specified in the preceding (1) (A) and (B) may be conducted individually.

(3) In the case of the fuel tank of supports which can be regarded as those of the same type manufactured at the same manufacturing plant, implementation of the second and subsequent tests of fuel tanks and supports specified in the preceding (1) (B) may be omitted when deemed acceptable by the Society.

**503. Independent Tank Type B [See Rules]****1. Structural Test and Tightness test for fuel tanks**

- (1) Refer to the requirements in **501. 1** and **502. 1**.

**504. Independent Tank Type C [See Rules]****1. Hydrostatic or hydropneumatic test for independent tank**

- (1) The "pressure vessels other than simple cylindrical and spherical pressure vessels" referred to in the requirements in **504. 1** of the Rules means those cylindrical or spherical pressure vessels with supporting structures of well proved records. In tanks of special shape having supporting structures likely to cause excessive bending stress or bicylindrical shape tanks, the stress levels are to be verified by strain measurement through prototype test.
- (2) "Where necessary" referred to in the requirements in **504. 4** of the Rules means a case in which the shipbuilding berth or hull structure can not withstand the hydrostatic load when fuel tanks are filled with water to the tank top level and another case in which a large load exceeding the design load is imposed on the structural members of the tank or adjacent structures by conducting the hydrostatic test.
- (3) In applying **504. 6** of the Rules, the leakage test is to be of the airtightness test conducted at a pressure of MARVS or more of the pressure vessel.

**505. Membrane Tank [See Rules]****1. Design development testing**

- (1) Tests specified in the requirements in **505. 1 (1)** of the Rules, are to be conducted on a model in combination of the primary barrier, insulation structure and secondary barrier. Test object and testing procedure are to be determined for each type of tank in each case.

**2. Hull structure adjacent to membrane tanks**

- (1) The "hydrostatically tested" referred to in the requirements in **505. 2 (1)** of the Rules means the hydraulic test according to the requirements in **Pt 3, Ch 1, 209. of Rules for the Classification of Steel Ships.** of the Rules. In this case, hydraulic pressure may be applied from hull structures such as ballast tanks and cofferdams.
- (2) The leakage test for the "all hold structure supporting the membrane" referred to in the requirements in **505. 2 (2)** of the Rules is to be in accordance with the testing procedure applicable to general hull structures as specified in **Pt 3, Ch 1, 209. of Rules for the Classification of Steel Ships.**

## Section 7 Testing Regulations

**701. Testing of piping components [See Rules]**

1. In applying **701. 1** of this Rules, test requirements of valves are in accordance with **Annex 1**.
2. In applying **701. 1 (4)** of this Rules, standards recognized by Society means **ISO 19921** and **ISO 19922**.

**703. Type testing of fuel pumps and gas compressors [See Rules]**

1. In applying **703** of this Rules, "the Guidance specified separately" means **Annex 1.↓**

---

---

# Annex 1 Requirements for Equipment Used for Low-flashpoint Fuel Supply Systems

## Section 1 General

### 101. Application

This annex applies to equipment for the fuel supply system used in ships using low-flashpoint fuels in accordance with relevant requirements in the Rule.

### 102. General

1. In case of cases not specified in this Annex, relevant requirements in **Rules for the Classification of Steel Ships** are to be applied.
2. The tests specified in this Annex are to be carried out at manufacturing plants at presence of the Surveyor. At the request of the manufacturer, however, parts or all of these tests may be carried out after installation on board ship in cases where deemed appropriate by the Society.

### 103. Definition

1. **Dry screw compressor** means a screw compressor that uses no liquid for sealing the rotor clearances and driving the non-coupled rotor. The non-coupled rotor is driven by the coupled rotor through the timing gears.
2. **Flooded screw compressor** means a screw compressor with a lubricant (compatible with the process gas) injected into the rotor area.
3. **Overload** means highest flow point at which the predicted performance curve terminates on a speed line.
4. **Critical speed** means a shaft rotational speed at which rotating shaft system is in a state of resonance.
5. **Maximum continuous speed** means highest rotational speed at which is capable of safe and continuous operation in intended condition.

## Section 2 Centrifugal Gas Compressors

### 201. General

1. Requirements in this Section applies to centrifugal gas compressors.
2. Requirements of prime movers such as turbines and electric motors, and their respective power transmission systems used for driving gas compressors are to comply with relevant requirements in **Pt 5** and **Pt 6** of **Rules for the Classification of Steel Ships** are to be applied.
3. For equipment, etc. manufactured in accordance with the requirements of rules or standards which are recognized to be equivalent to those contained in this annex by the Society, may be applied in lieu of application of this Annex in cases where deemed appropriate by the Society.

Standard No.	Standard Title
ASME	Boiler and Pressure Vessel Code, Section VIII
API Std 617	Axial and Centrifugal Compressors and Expander Compressors for Petroleum, Chemical and Gas Industry Services
ASME B31.3	Process Piping

### 202. Submission of Plans and Documents

1. Plans and documents for approval
  - (1) Shaft drawings including material specifications and strength calculation
  - (2) Casing drawings including material specifications and strength calculation
  - (3) Sectional assembly
  - (4) Local piping diagrams relating to the equipment
  - (5) Diagrams of control systems
2. Plans and documents for reference
  - (1) Main particulars(kind of prime mover, output, number of revolution, and capacity)
  - (2) Data relating to the thermal deformation of the low temperature parts(where used in cryogenic service)
  - (3) Strength calculation sheets for structural parts(thermal stress calculations are to be included where deemed necessary)
  - (4) List of spare parts

### 203. Material

1. Materials used for main structural parts are to be suitable for their respective working conditions, such as service temperatures, pressures, etc. In addition, materials to be used for pressure-bearing parts and power transmission shafts of prime mover having output of 100 kW are to be in accordance with relevant requirements in **Pt 2, Ch 1** of **Rules for the Classification of Steel Ships**.
2. Materials used for main structural parts whose design temperatures do not exceed -55°C are to be in accordance with relevant requirements in **Pt 2, Ch 1** of **Rules for the Classification of Steel Ships** and **Ch 7, Sec 4, Table 7.4** of Rules.
3. The non-destructive tests specified in **Pt 2, Ch 1, 501.10** and **601.10** of **Rules for the Classification of Steel Ships** may be requested for main structural parts in cases where deemed necessary by the Society.
4. The main structural parts of gas compressors specified in this chapter are as following:
  - (1) Impellers
  - (2) Inducers
  - (3) Guide vanes
  - (4) Casings
  - (5) Shafts and couplings

## 204. Construction and Installation

1. Gas compressors are to be free from gas leakage as far as practicable and to be of a non-sparking construction.
2. The shaft sealing of gas compressors is to be according to the followings;
  - (1) Sufficient gas sealing ability at service temperature and pressure is to be provided, and construction it to be durable enough to permit continuous operation, and
  - (2) Construction is to be such that no gas leakage or ingress of atmospheric air occurs when the gas compressor stops.
3. Suitable means are to be provided so that no excessive forces are imposed upon gas compressors due to any deformation of the piping connected thereto and ship deflections.
4. In cases where gas compressors are driven by steam turbines installed in the same compartment, the temperature of the steam to drive the turbine is to be sufficiently safe by being lower than the spontaneous ignition temperature of boil-off gas.
5. Gas compressors, including driving machines and power transmission systems, are to be capable of withstanding the mechanical and thermal loads, and vibrations encountered under normal working conditions.
6. Gas compressors are to be constructed so as to allow gas purging without difficulty at times of overhauling and are to be provided with suitable purge connections.
7. The overload condition is to be indicated on performance curve. The sectional overload condition shall be at least 115% of the rated condition.

## 205. Strength

1. Casings are to be designed in accordance with one of the followings:
  - (1) The thicknesses of casings are to have values not less than those determined by the requirements in **Pt 5, Ch 5, 306. to 309. of Rules for the Classification of Steel Ships.** However, allowable stress are to be in accordance with **Ch 6, 415. 3 (3) (A), Table 6.4** of Rules.
  - (2) Casing may be designed with the aid finite element analysis provided that design limits comply with Section VIII, Division 2 of ASME Code stress intensity.
  - (3) Casings may be designed in accordance with recognized standards.
2. Strength of impeller shaft is to be in accordance with **Pt 5, Ch 3, 303. of Rules for the Classification of Steel Ships.**

## 206. Safety devices

### 1. General

Gas compressors are to be provided with protective equipment and monitoring systems to sufficiently ensure safe and stable operating performance according to compressor type and service conditions.

### 2. Monitoring Systems and Safety Devices

Gas compressors are to be provided with alarm systems, or alarm system and shutdown systems as the followings, but not limited to:

Parameter (H=High L=Low O=Abnormal condition)		Alarm	Shut down
gas discharge temperature	H	●	●
gas discharge pressure	H	●	●
lubricating systems	O	●	●
overspeed	O	●	

### 3. Emergency shutdown systems

Gas compressors are to be provided with emergency shutdown systems which can be operated locally as well as remotely from a control station.

### 4. Critical speed

- (1) For rigid shafts, the lateral critical speed is to be not less than 120% of the maximum service speed.
- (2) For flexible shafts, the primary lateral critical speed is to be equal to or less than 85% of the minimum service speed and the secondary lateral critical speed is to be equal to or more than 120% of the maximum service speed.
- (3) Torsional natural frequencies of rotating shaft systems are to be at least 10 % above or 10 % below any service speed range.

## 207. Lubricating systems

1. Lubricating systems of gas compressors whose bearings are forced lubricated are to be in accordance with the following;
  - (1) The system is of such a construction that no ingress of gas into the lubricating oil is permitted.
  - (2) The lubricating oil strainers are to be provided.
  - (3) Means to maintain lubricating oil temperature at an appropriate level to be provided.

## 208. Tests and inspections

1. Parts subject to internal pressure are to be subjected to hydraulic test at the pressure of 1.5 times the design pressure.
2. The assembled compressor (including end seals) is to be tested for gas leakage with helium or nitrogen at the design pressure. However, for compressors handling gases with molar mass equal to or less than 12, helium is to be used for the test.
3. After assembly, a operation test including performance test is to be performed and overspeed test is to be performed at not less than 115 % of maximum continuous speed.

## Section 3 Reciprocating Gas Compressors

### 301. General

1. Requirements in this Section applies to reciprocating gas compressors.
2. Requirements of prime movers such as turbines and electric motors, and their respective power transmission systems used for driving gas compressors are to comply with relevant requirements in **Pt 5** and **Pt 6** of **Rules for the Classification of Steel Ships** are to be applied.
3. For equipment, etc. manufactured in accordance with the requirements of rules or standards which are recognized to be equivalent to those contained in this annex by the Society, may be applied in lieu of application of this Annex in cases where deemed appropriate by the Society.

Standard No.	Standard Title
ASME	Boiler and Pressure Vessel Code, Section VIII
API Std 618	Reciprocating Compressors for Petroleum, Chemical, and Gas Industry Services
ASME B31.3	Process Piping

### 302. Submission of Plans and Documents

1. Plans and documents for approval
  - (1) Crank shaft drawings including material specifications and strength calculation
  - (2) Cylinder drawings including material specifications and strength calculation
  - (3) Sectional assembly
  - (4) Local piping diagrams relating to the equipment
  - (5) Diagrams of control systems
2. Plans and documents for reference
  - (1) Main particulars(kind of prime mover, output, number of revolution, and capacity)
  - (2) Data relating to the thermal deformation of the low temperature parts(where used in cryogenic service)
  - (3) Strength calculation sheets for structural parts(thermal stress calculations are to be included where deemed necessary)
  - (4) List of spare parts

### 303. Material

1. Materials used for main structural parts are to be suitable for their respective working conditions, such as service temperatures, pressures, etc. In addition, materials to be used for pressure-bearing parts and power transmission shafts of prime mover having output of 100 kW are to be in accordance with relevant requirements in **Pt 2, Ch 1** of **Rules for the Classification of Steel Ships**.
2. Materials used for main structural parts whose design temperatures do not exceed -55°C are to be in accordance with relevant requirements in **Pt 2, Ch 1** of **Rules for the Classification of Steel Ships** and **Ch 7, Sec 4, Table 7.4** of Rules.
3. The non-destructive tests specified in **Pt 2, Ch 1, 501.10** and **601.10** of **Rules for the Classification of Steel Ships** may be requested for main structural parts in cases where deemed necessary by the Society.
4. The main structural parts of gas compressors specified in this chapter are as following:
  - (1) cylinder covers and valve cover
  - (2) cylinder liners
  - (3) Pistons and piston rods/connecting rods
  - (4) crankshafts and shaft couplings
  - (5) crankcase.bed and frame)

### 304. Construction and Installation

1. Gas compressors are to be free from gas leakage as far as practicable and to be of a non-sparking construction.
2. The shaft sealing of gas compressors is to be according to the followings;
  - (1) Sufficient gas sealing ability at service temperature and pressure is to be provided, and construction is to be durable enough to permit continuous operation, and
  - (2) Construction is to be such that no gas leakage or ingress of atmospheric air occurs when the gas compressor stops.
3. Suitable means are to be provided so that no excessive forces are imposed upon gas compressors due to any deformation of the piping connected thereto and ship deflections.
4. In cases where gas compressors are driven by steam turbines installed in the same compartment, the temperature of the steam to drive the turbine is to be sufficiently safe by being lower than the spontaneous ignition temperature of boil-off gas.
5. Gas compressors, including driving machines and power transmission systems, are to be capable of withstanding the mechanical and thermal loads, and vibrations encountered under normal working conditions.
6. Gas compressors are to be constructed so as to allow gas purging without difficulty at times of overhauling and are to be provided with suitable purge connections.
7. Discharge temperature of the gas compressor is not to exceed 150 °C.

### 305. Strength

1. Cylinders are to be designed in accordance with one of the followings:
  - (1) The thicknesses of cylinders are to have values not less than those determined by the requirements in **Pt 5, Ch 5, 306. to 309. of Rules for the Classification of Steel Ships.** However, allowable stress are to be in accordance with **Ch 6, 415. 3 (3) (A), Table 6.4** of Rules.
  - (2) Cylinders may be designed with the aid finite element analysis provided that design limits comply with Section VIII, Division 2 of ASME Code stress intensity.
  - (3) Cylinders may be designed in accordance with recognized standards.
2. Strength of crankshaft is to be in accordance with **Pt 5, Ch 6, 1102. of Rules for the Classification of Steel Ships.** However, for gas compressors with working pressure above 4 MPa, the results of structural analysis in accordance with recognized standards may be accepted.

### 306. Safety devices

#### 1. General

Gas compressors are to be provided with protective equipment and monitoring systems to sufficiently ensure safe and stable operating performance according to compressor type and service conditions.

#### 2. Monitoring Systems and Safety Devices

Gas compressors are to be provided with alarm systems, or alarm system and shutdown systems as the followings, but not limited to:

Parameter (H=High L=Low O=Abnormal condition)		Alarm	Shut down
gas discharge temperature of each cylinder	H	●	●
gas discharge pressure	H	●	●
frame lubricating oil pressure	L	●	●
frame lubricating oil temperature	H	●	
cylinder lubricating systems	O	●	
cylinder cooling systems	O	●	

### 3. Emergency shutdown systems

Gas compressors are to be provided with emergency shutdown systems which can be operated locally as well as remotely from a control station.

### 4. Critical speed

Torsional natural frequencies of rotating shaft systems are to be at least 10 % above or 10 % below any service speed range.

### 5. Safety valves

A safety valve is to be fitted at discharge side.

## 307. Lubricating systems

1. For Compressors 150 kW and above, the frame lubrication system shall be a pressurized system is to be pressurized system.
2. The crankcase oil temperature is not to exceed 70 °C and a high temperature alarm is to be provided. Means to maintain lubricating oil temperature at an appropriate level to be provided.
3. The lubricating oil strainers are to be provided.
4. The system is to be of such a construction that no ingress of gas into the lubricating oil is permitted.

## 308. Cylinder cooling systems

1. Cylinder cooling systems are to be provided.
2. The system is to be of such a construction that no ingress of gas into the cooling system is permitted.

## 309. Tests and inspections

1. Parts subject to internal pressure are to be subjected to hydraulic test at the pressure of 1.5 times the design pressure.
2. Cylinders are to be leak-tested with helium or nitrogen at the design pressure without liners, but with cylinder covers, valve covers, etc. to ensure no leakage at connection parts. However, for compressors handling gases with molar mass equal to or less than 12, helium is to be used for the test.
3. After assembly, a operation test including performance test is to be performed before installation on board.

## Section 4 Screw Gas Compressors

### 401. General

1. Requirements in this Section applies to screw gas compressors.
2. Requirements of prime movers such as turbines and electric motors, and their respective power transmission systems used for driving gas compressors are to comply with relevant requirements in **Pt 5 and Pt 6 of Rules for the Classification of Steel Ships** are to be applied.
3. For equipment, etc. manufactured in accordance with the requirements of rules or standards which are recognized to be equivalent to those contained in this annex by the Society, may be applied in lieu of application of this Annex in cases where deemed appropriate by the Society.

Standard No.	Standard Title
ASME	Boiler and Pressure Vessel Code, Section VIII
API Std 619	Rotary-Type Positive-Displacement Compressors for Petroleum, Petrochemical, and Natural Gas Industries
ASME B31.3	Process Piping

### 402. Submission of Plans and Documents

1. Plans and documents for approval
  - (1) Rotor drawings including material specifications and strength calculation
  - (2) Casing drawings including material specifications and strength calculation
  - (3) Sectional assembly
  - (4) Local piping diagrams relating to the equipment
  - (5) Diagrams of control systems
2. Plans and documents for reference
  - (1) Main particulars(kind of prime mover, output, number of revolution, and capacity)
  - (2) Data relating to the thermal deformation of the low temperature parts(where used in cryogenic service)
  - (3) Strength calculation sheets for structural parts(thermal stress calculations are to be included where deemed necessary)
  - (4) List of spare parts

### 403. Material

1. Materials used for main structural parts are to be suitable for their respective working conditions, such as service temperatures, pressures, etc. In addition, materials to be used for pressure-bearing parts and power transmission shafts of prime mover having output of 100 kW are to be in accordance with relevant requirements in **Pt 2, Ch 1 of Rules for the Classification of Steel Ships**.
2. Materials used for main structural parts whose design temperatures do not exceed -55°C are to be in accordance with relevant requirements in **Pt 2, Ch 1 of Rules for the Classification of Steel Ships** and **Ch 7, Sec 4, Table 7.4** of Rules.
3. The non-destructive tests specified in **Pt 2, Ch 1, 501.10** and **601.10** of **Rules for the Classification of Steel Ships** may be requested for main structural parts in cases where deemed necessary by the Society.
4. The main structural parts of gas compressors specified in this chapter are as following:
  - (1) Rotor
  - (2) Impeller

### 404. Construction and Installation

1. Gas compressors are to be free from gas leakage as far as practicable and to be of a non-sparking construction.

2. The shaft sealing of gas compressors is to be according to the followings;
  - (1) Sufficient gas sealing ability at service temperature and pressure is to be provided, and construction it to be durable enough to permit continuous operation, and
  - (2) Construction is to be such that no gas leakage or ingress of atmospheric air occurs when the gas compressor stops.
3. Suitable means are to be provided so that no excessive forces are imposed upon gas compressors due to any deformation of the piping connected thereto and ship deflections.
4. In cases where gas compressors are driven by steam turbines installed in the same compartment, the temperature of the steam to drive the turbine is to be sufficiently safe by being lower than the spontaneous ignition temperature of boil-off gas.
5. Gas compressors, including driving machines and power transmission systems, are to be capable of withstanding the mechanical and thermal loads, and vibrations encountered under normal working conditions.
6. Gas compressors are to be constructed so as to allow gas purging without difficulty at times of overhauling and are to be provided with suitable purge connections.

#### 405. Strength

1. Casings are to be designed in accordance with one of the followings:
  - (1) The thicknesses of casings are to have values not less than those determined by the requirements in **Pt 5, Ch 5, 306. to 309. of Rules for the Classification of Steel Ships.** However, allowable stress are to be in accordance with **Ch 6, 415. 3 (3) (A), Table 6.4** of Rules.
  - (2) Casing may be designed with the aid finite element analysis provided that design limits comply with Section VIII, Division 2 of ASME Code stress intensity.
  - (3) Casings may be designed in accordance with recognized standards.
2. Strength of screw shaft is to be in accordance with **Pt 5, Ch 3, 203. of Rules for the Classification of Steel Ships.**

#### 406. Safety devices

##### 1. General

Gas compressors are to be provided with protective equipment and monitoring systems to sufficiently ensure safe and stable operating performance according to compressor type and service conditions.

##### 2. Monitoring Systems and Safety Devices

Gas compressors are to be provided with alarm systems, or alarm system and shutdown systems as the followings, but not limited to:

Parameter (H=High L=Low O=Abnormal condition)		Alarm	Shut down
gas discharge temperature	H	●	●
gas discharge pressure	H	●	●
lubricating systems	O	●	●
overspeed	O	●	

##### 3. Emergency shutdown systems

Gas compressors are to be provided with emergency shutdown systems which can be operated locally as well as remotely from a control station.

#### 4. Critical speed

- (1) Rotors are to be of a rigid construction with the lateral critical speed is to be not less than 120% of the maximum service speed.
- (2) Torsional natural frequencies of rotating shaft systems are to be at least 10 % above or 10 % below any service speed range.

#### 5. Safety valves

A safety valve is to be fitted at discharge side.

### 407. Lubricating systems

1. Unless otherwise accepted by the Society, a pressurized lubricating oil system is to be provided.
2. Lubricating systems of dry screw compressors are to be in accordance with the following;
  - (1) The lubricating oil strainers are to be provided.
  - (2) The system is to be of such a construction that no ingress of gas into the lubricating oil is permitted.
3. Lubricating systems of flooded screw compressors are to be in accordance with the following;
  - (1) The lubricating oil strainers are to be provided.
  - (2) The discharge temperature is to be maintained at least 10 °C higher than the dew point of the gas components.
  - (3) Means to maintain lubricating oil temperature at an appropriate level to be provided.
  - (4) An oil separator is to be provided and oil contents(ppm) in discharge gas are to be limited at an appropriate level for service condition.
  - (5) Lubricating systems are not to be installed in non hazardous area.

### 408. Tests and inspections

1. Parts subject to internal pressure are to be subjected to hydraulic test at the pressure of 1.5 times the design pressure.
2. The assembled compressor (including end seals) is to be tested for gas leakage with helium or nitrogen at the design pressure. However, for compressors handling gases with molar mass equal to or less than 12, helium is to be used for the test.
3. After assembly, a operation test including performance test is to be performed.

## Section 5 Centrifugal Pumps

### 501. General

1. Requirements in this Section applies to submerged pumps, deep well pumps and deck-mounted centrifugal pumps.
2. Requirements of prime movers such as turbines and electric motors, and their respective power transmission systems used for driving pumps are to comply with relevant requirements in **Pt 5** and **Pt 6** of **Rules for the Classification of Steel Ships** are to be applied.
3. For equipment, etc. manufactured in accordance with the requirements of rules or standards which are recognized to be equivalent to those contained in this annex by the Society, may be applied in lieu of application of this Annex in cases where deemed appropriate by the Society.

Standard No.	Standard Title
ASME	Boiler and Pressure Vessel Code, Section VIII
API Std 610	Centrifugal Pumps for Petroleum, Petrochemical and Natural Gas Industries
ASME B31.3	Process Piping

### 502. Submission of Plans and Documents

1. Plans and documents for approval
  - (1) Shaft drawings including material specifications and strength calculation
  - (2) Casing drawings including material specifications and strength calculation
  - (3) Sectional assembly
  - (4) Local piping diagrams relating to the equipment
  - (5) Diagrams of control systems
2. Plans and documents for reference
  - (1) Main particulars(kind of prime mover, output, number of revolution, and capacity)
  - (2) Data relating to the thermal deformation of the low temperature parts(where used in cryogenic service)
  - (3) Strength calculation sheets for structural parts(thermal stress calculations are to be included where deemed necessary)
  - (4) List of spare parts

### 503. Material

1. Materials used for main structural parts are to be suitable for their respective working conditions, such as service temperatures, pressures, etc. In addition, materials to be used for pressure-bearing parts and power transmission shafts of prime mover having output of 100 kW and above are to be in accordance with relevant requirements in **Pt 2, Ch 1** of **Rules for the Classification of Steel Ships**.
2. Materials used for main structural parts whose design temperatures do not exceed -55°C are to be in accordance with relevant requirements in **Pt 2, Ch 1** of **Rules for the Classification of Steel Ships** and **Ch 7, Sec 4, Table 7.4** of Rules.
3. The non-destructive tests specified in **Pt 2, Ch 1, 501. 10** and **601. 10** of **Rules for the Classification of Steel Ships** may be requested for main structural parts in cases where deemed necessary by the Society.
4. The main structural parts of pumps specified in this chapter are as following:
  - (1) Impellers
  - (2) Inducers
  - (3) Casings
  - (4) Shafts and couplings

## 504. Construction and Installation

1. Pumps are to be of a non-sparking construction.
2. Pumps are to be such that sufficient consideration is given to preventing the generation of cavitation.
3. The electrical insulation materials and insulated cables of the driving motors of submerged type pumps are to sufficiently withstand the service environment, and the insulation resistance of the motor is not to be less than the value specified in **Pt 6 of Rules for the Classification of Steel Ships**.
4. Pumps handling with fuel at low temperatures are to be of a construction which gives sufficient consideration to the effects of thermal contraction.
5. The shaft sealing assemblies of deepwell type pumps and deck-mounted type pumps are to be of the construction specified in followings;
  - (1) Sufficient sealing ability at service temperature and pressure is to be provided, and construction it to be durable enough to permit continuous operation, and
  - (2) Construction is to be such that no leakage or ingress of atmospheric air occurs when the pump stops.
6. Suitable means are to be provided so that no excessive forces are imposed upon pumps due to any deformation of the piping connected thereto and ship deflections.
7. Suitable strainers in accordance with the relevant fuel properties are to be provided at the suction parts of pumps as necessary.

## 505. Strength

1. Casings are to be designed in accordance with one of the followings:
  - (1) The thicknesses of casings are to have values not less than those determined by the requirements in **Pt 5, Ch 5, 306. to 309. of Rules for the Classification of Steel Ships**. However, allowable stress are to be in accordance with **Ch 6, 415. 3 (3) (A), Table 6.4** of Rules.
  - (2) Casing may be designed with the aid finite element analysis provided that design limits comply with Section VIII, Division 2 of ASME Code stress intensity.
  - (3) Casings may be designed in accordance with recognized standards.
2. Strength of impeller shaft is to be in accordance with **Pt 5, Ch 3, 303. of Rules for the Classification of Steel Ships**.

## 506. Safety devices

### 1. General

Pumps are to be provided with protective equipment and monitoring systems to sufficiently ensure safe and stable operating performance according to pump type and service conditions.

### 2. Monitoring Systems and Safety Devices

Pumps are to be provided with alarm systems, or alarm system and shutdown systems as the followings, but not limited to:

- (1) low discharge pressure,
- (2) over currents and abnormal drops of current, and
- (3) others deemed necessary by the Society

## 507. Lubricating systems

1. Forced lubricated pumps are to be provided with filters at the inlets of the lubricating oil.
2. Forced lubricated pumps are to be Sufficiently considered for properties related to lubrication, such as viscosity and temperature, as well as compatibility with bearing materials.

## 508. Tests and inspections

### 1. Type tests

Pumps are to be type approved in accordance with accordance with **Ch 3, Sec. 15** of the **Guidance for Approval of Manufacturing Process and Type Approval, etc.**

### 2. Production tests

- (1) All pumps which have been type approved are subject to the tests of following (a) and (b) at the plant of manufacturer in the presence of the Surveyor.
  - (A) hydrostatic test of the pump body equal to 1.5 times the design pressure
  - (B) the capacity tests in compliance with the following
    - (a) For submerged pumps and deck-mounted pumps, the capacity test is to be carried out with the design medium or with a medium below the minimum working temperature.
    - (b) For deep well pumps, the capacity test may be carried out with water.
- (2) The manufacturer may request the Society to waive the tests required in above (B) subject to the following:
  - (A) The pump has been type approved as required by **Par 1**.
  - (B) The manufacturer has a recognised quality system that has been assessed and certified by the Society subject to periodic audits
  - (C) The quality control plan contains a provision to subject each pump to a hydrostatic test of the pump body equal to 1.5 times the design pressure and a capacity test. The manufacturer is to maintain records of such tests.

## Section 6 Reciprocating Pumps

### 601. General

1. Requirements in this Section applies to reciprocating pumps.
2. Requirements of prime movers such as turbines and electric motors, and their respective power transmission systems used for driving pumps are to comply with relevant requirements in **Pt 5** and **Pt 6** of **Rules for the Classification of Steel Ships** are to be applied.
3. For equipment, etc. manufactured in accordance with the requirements of rules or standards which are recognized to be equivalent to those contained in this annex by the Society, may be applied in lieu of application of this Annex in cases where deemed appropriate by the Society.

Standard No.	Standard Title
ASME	Boiler and Pressure Vessel Code, Section VIII
API Std 674	Displacement pumps-reciprocating
ASME B31.3	Process Piping

### 602. Submission of Plans and Documents

1. Plans and documents for approval
  - (1) Crank shaft drawings including material specifications and strength calculation
  - (2) Cylinder drawings including material specifications and strength calculation
  - (3) Sectional assembly
  - (4) Local piping diagrams relating to the equipment
  - (5) Diagrams of control systems
2. Plans and documents for reference
  - (1) Main particulars(kind of prime mover, output, number of revolution, and capacity)
  - (2) Data relating to the thermal deformation of the low temperature parts(where used in cryogenic service)
  - (3) Strength calculation sheets for structural parts(thermal stress calculations are to be included where deemed necessary)
  - (4) List of spare parts

### 603. Material

1. Materials used for main structural parts are to be suitable for their respective working conditions, such as service temperatures, pressures, etc. In addition, materials to be used for pressure-bearing parts and power transmission shafts of prime mover having output of 100 kW are to be in accordance with relevant requirements in **Pt 2, Ch 1** of **Rules for the Classification of Steel Ships**.
2. Materials used for main structural parts whose design temperatures do not exceed -55°C are to be in accordance with relevant requirements in **Pt 2, Ch 1** of **Rules for the Classification of Steel Ships** and **Ch 7, Sec 4, Table 7.4** of Rules.
3. The non-destructive tests specified in **Pt 2, Ch 1, 501.10** and **601.10** of **Rules for the Classification of Steel Ships** may be requested for main structural parts in cases where deemed necessary by the Society.
4. The main structural parts of pumps specified in this chapter are as following:
  - (1) cylinder covers and valve cover
  - (2) cylinder liners
  - (3) Pistons and piston rods/connecting rods
  - (4) crankshafts and shaft couplings
  - (5) crankcase(beds and frame)

## 604. Construction and Installation

1. Pumps are to be of a non-sparking construction.
2. Pumps handling with fuel at low temperatures are to be of a construction which gives sufficient consideration to the effects of thermal contraction.
3. The shaft sealing assemblies of pumps are to be of the construction specified in followings;
  - (1) Sufficient sealing ability at service temperature and pressure is to be provided, and construction it to be durable enough to permit continuous operation, and
  - (2) Construction is to be such that no leakage or ingress of atmospheric air occurs when the pump stops.
4. Suitable means are to be provided so that no excessive forces are imposed upon pumps due to any deformation of the piping connected thereto and ship deflections.
5. Suitable strainers in accordance with the relevant fuel properties are to be provided at the suction parts of pumps as necessary.

## 605. Strength

1. Cylinders are to be designed in accordance with one of the followings:
  - (1) The thicknesses of cylinders are to have values not less than those determined by the requirements in **Pt 5, Ch 5, 306. to 309. of Rules for the Classification of Steel Ships**. However, allowable stress are to be in accordance with **Ch 6, 415. 3 (3) (A), Table 6.4** of Rules.
  - (2) Cylinders may be designed with the aid finite element analysis provided that design limits comply with Section VIII, Division 2 of ASME Code stress intensity.
  - (3) Cylinders may be designed in accordance with recognized standards.
2. Strength of crankshaft is to be in accordance with **Pt 5, Ch 6, 1102. of Rules for the Classification of Steel Ships**. However, for pumps with working pressure above 4 MPa, the results of structural analysis in accordance with recognized standards may be accepted.

## 606. Safety devices

### 1. General

Pumps are to be provided with protective equipment and monitoring systems to sufficiently ensure safe and stable operating performance according to pump type and service conditions.

### 2. Monitoring Systems and Safety Devices

Pumps are to be provided with alarm systems, or alarm system and shutdown systems as the followings, but not limited to:

Parameter (H=High L=Low O=Abnormal condition)		Alarm	Shut down
discharge pressure	H	●	●
discharge temperature	H	●	●
frame lubricating oil temperature	H	●	●
cylinder lubricating systems	O	●	
cylinder cooling systems	O	●	

### 3. Safety valves

A safety valve is to be fitted at discharge side.

## 607. Lubricating systems

1. Forced lubricated pumps are to be provided with filters at the inlets of the lubricating oil.
2. Forced lubricated pumps are to be sufficiently considered for properties related to lubrication, such as viscosity and temperature, as well as compatibility with bearing materials.

## 608. Tests and inspections

### 1. Type tests

Pumps are to be type approved in accordance with accordance with **Ch 3, Sec. 15** of the **Guidance for Approval of Manufacturing Process and Type Approval, etc.**

### 2. Production tests

- (1) All pumps which have been type approved are subject to the tests of following (a) and (b) at the plant of manufacturer in the presence of the Surveyor.
  - (A) hydrostatic test of the pump body equal to 1.5 times the design pressure
  - (B) The capacity test is to be carried out with the design medium or with a medium below the design temperature.
- (2) The manufacturer may request the Society to waive the tests required in above (B) subject to the following:
  - (A) The pump has been type approved as required by **Par 1**.
  - (B) The manufacturer has a recognised quality system that has been assessed and certified by the Society subject to periodic audits
  - (C) The quality control plan contains a provision to subject each pump to a hydrostatic test of the pump body equal to 1.5 times the design pressure and a capacity test. The manufacturer is to maintain records of such tests.

## Section 7 Heat Exchangers

### 701. General

1. Requirements in this Section applies to tubular heat exchangers. Other type of heat exchangers are to be as deemed appropriate by the Society.
2. For equipment, etc. manufactured in accordance with the requirements of rules or standards which are recognized to be equivalent to those contained in this annex by the Society, may be applied in lieu of application of this Annex in cases where deemed appropriate by the Society.

Standard No.	Standard Title
TEMA	Standards of Tubular Exchanger
ASME	Boiler and Pressure Vessel Code, Section VIII
ASME B31.3	Process Piping

### 702. Submission of Plans and Documents

1. Plans and documents for approval
  - (1) Material specifications and strength calculation
  - (3) Sectional assembly
2. Plans and documents for reference
  - (1) Design data including design pressures and temperatures, fluid name, degree of radiographic examination, corrosion allowance, heat treatment, hydrostatic test pressure, setting of safety relief valve
  - (2) Shell and head details, and shell to head joint details
  - (3) Nozzles, openings, manways, etc., and their attachment details; flanges and covers, as applicable
  - (4) Tubes, tube sheets, heads, shell flanges, covers, baffles, tube to tubesheet joint details, packings

### 703. Material

1. Materials used for structural parts which contact with fuel liquids or vapours are to be in accordance with relevant requirements in **Pt 2, Ch 1 of Rules for the Classification of Steel Ships** and **Ch 7, Sec 4**.
2. Materials used for structural parts which do not contact with fuel liquids or vapours are to be in accordance with relevant requirements in **Pt 5, Ch 5, 303. of Rules for the Classification of Steel Ships** depending upon the type of refrigerant or heating media used as well as the design temperature and the design pressure.

### 704. Construction and strength

1. Structural parts which contact with fuel liquids or vapours are to be designed in accordance with requirements relative to Group 1 pressure vessels and heat exchangers specified in **Pt 5, Ch 5, Sec 3 of Rules for the Classification of Steel Ships** and **Pt 7, Ch 5, Sec 5 of Rules for the Classification of Steel Ships** regardless of the design temperature and the design pressure.
2. In application of **Par 1**, allowable stresses used in strength calculation for tubes which contact with fuel liquids or vapours are to be in accordance with **Ch 6, 415. 3 (3) (A), Table 6.4** of Rules.
3. Materials used for structural parts which do not contact with fuel liquids or vapours are to be in accordance with relevant requirements in **Pt 5, Ch 5, 303. of Rules for the Classification of Steel Ships** depending upon the type of refrigerant or heating media used as well as the design temperature and the design pressure.
4. Heat exchangers whose design temperatures are below  $-55^{\circ}\text{C}$  are to be subjected to strength analysis for thermal stress in accordance with ASME Boiler and Pressure Vessel Code, Section VIII Div.2 or recognized standards.

**705. Safety devices**

1. The followings are to be applied protect of the system from overpressure.
  - (1) A shell, where internal pressure may exceed the design pressure due to tube failure, is to be provided with a suitable relief valve.
  - (2) Tubes, where internal pressure may exceed the design pressure due to isolation in a liquid full condition, are to be provided with relief valves. relief valves are to have a relieving capacity to discharge vapour specified in **Ch 6, 703. 1 (1) (B)** with not more than a 20 % rise in tube pressure above the MARVS.
2. Detection device is to be provided to detect fuel liquids or vapours ingress into heating medium systems.

**706. Tests and inspections**

1. Tubes and shells of All heat exchangers are to are to be subjected to hydraulic test accordance with the requirements in **Pt 5, Ch 5, Sec 3 of Rules for the Classification of Steel Ships**
2. After assembly, tubes which contact with fuel liquids or vapours is to be subjected to a leak test using air, or other suitable medium at the design pressure.

## Section 8 Valves

### 801. General

1. Requirements in this Section applies to valves used in fuel and process piping. However, pressure relief valves are to be in accordance with **Sec 9**.
2. For equipment, etc. manufactured in accordance with the requirements of rules or standards which are recognized to be equivalent to those contained in this annex by the Society, may be applied in lieu of application of this Annex in cases where deemed appropriate by the Society.

Standard No.	Standard Title
SIGGTO	Selection and testing of valves for LNG
BS 6364	Specification for valves for cryogenic service

### 802. Material

1. The materials used for pressure-bearing parts are to comply with the relevant requirements in **Pt 2, Ch 1 of Rules for the Classification of Steel Ships** and **Ch 7, Sec 4** of the Rules. However, for materials used in pipings as specified in the following (1) through (3), those conforming to recognized standards as deemed appropriate by the Society may be used where they comply with the requirements in **Ch 7, Sec 4** of the Rules considering the design temperature.
  - (1) Valves used for fuel piping and process piping with the design pressure not exceeding 1.0 MPa and design temperature of 0°C or more.
  - (2) Valves used for fuel piping and process piping with the design pressure not exceeding 3.0 MPa and design temperature of 0°C or more and nominal diameter less than 100 A.
  - (3) Valves used for accessory piping or instrumentation piping with diameter not exceeding 25 mm irrespective of the design pressure and design temperature.
2. Notwithstanding the requirements in the preceding **Par 1**, valves used for the piping having open ends not coming to contact with the liquid fuel led from the pressure relieving valves of fuel tanks and fuel piping or process piping with the design temperature of -55°C or higher may not be made of the steel for low temperature services specified in **Ch 7, Sec 4** of the Rules. Further, its material may be such as to comply with recognized standards as deemed appropriate by the Society.

### 803. Tests and inspections

#### 1. Type tests

- (1) Valves intended to be used at a working temperature below -55°C are to be type approved in accordance with **Ch 3, Sec. 15** of the **Guidance for Approval of Manufacturing Process and Type Approval, etc.**
- (2) For valves intended to be used at a working temperature above -55°C, type approval is not required.

#### 2. Production tests

- (1) All valves are to be tested at the plant of manufacturer in the presence of the Surveyor including the following.
  - (A) Hydrostatic test of the valve body at a pressure equal to 1.5 times the design pressure for all valves.
  - (B) Seat and stem leakage test at a pressure equal to 1.1 times the design pressure for valves other than safety valves. In addition, cryogenic testing consisting of valve operation and leakage verification at design temperature for a minimum of 10% of each type and size of valve for valves other than safety valves intended to be used at a working temperature below -55°C.
  - (C) The set pressure of safety valves is to be tested at ambient temperature.
- (2) For valves used for isolation of instrumentation in piping not greater than 25 mm, unit production testing need not be witnessed by the Surveyor. Records of testing are to be submitted

for review.

- (3) The manufacturer may request the Society to waive the tests required in above (1) subject to the following.
  - (A) The valve has been type approved as required by **Par 1** for valves intended to be used at a working temperature below  $-55^{\circ}\text{C}$
  - (B) The manufacturer has a recognized quality system that has been assessed and certified by the Society subject to periodic audits
  - (C) The quality control plan contains a provision to subject the following and the manufacturer is to maintain records of such tests
    - (a) Each valve to a hydrostatic test of the valve body at a pressure equal to 1.5 times the design pressure for all valves.
    - (b) Seat and stem leakage test at a pressure equal to 1.1 times the design pressure for valves other than safety valves.
    - (c) The set pressure of safety valves is to be tested at ambient temperature.
  - (D) Cryogenic testing consisting of valve operation and leakage verification at the design temperature for a minimum of 10 % of each type and size of valve for valves other than safety valves intended to be used at a working temperature below  $-55^{\circ}\text{C}$  in the presence of the Society' representative.

## Section 9 Pressure Relief Valves

### 901. General

1. Requirements in this Section applies to valves used for fuel containment systems, process pressure vessels, fuel piping and process piping.
2. For equipment, etc. manufactured in accordance with the requirements of rules or standards which are recognized to be equivalent to those contained in this annex by the Society, may be applied in lieu of application of this Annex in cases where deemed appropriate by the Society.

Standard No.	Standard Title
SIGGTO	Selection and testing of valves for LNG
BS 6364	Specification for valves for cryogenic service
ISO 21013-1	Cryogenic vessels - Pressure-relief accessories for cryogenic service - Part 1: Reclosable pressure-relief valves
ISO 4126-1	Safety devices for protection against excessive pressure - Part 1: Safety valves

### 902. Material

1. Materials of relief valves whose design temperatures are not below 0°C are to be in accordance with relevant requirements in **Pt 2, Ch 1 of Rules for the Classification of Steel Ships**. However, Valves used for fuel piping and process piping with the design pressure not exceeding 3.0 MPa and design temperature of 0°C or more and nominal diameter less than 100 A.
2. Materials of relief valves whose design temperatures do not exceed 0°C are to be in accordance with relevant requirements of **PPt 2, Ch 1 of Rules for the Classification of Steel Ships** and **Ch 7, Sec 4** of the Rules.

### 903. Construction

1. Relief valves fitted for use on type C independent tanks and process pressure vessels are to be of the following (1) or (2) types. Valves of other types may be used subject to the approval of the Society.
  - (1) High lift type : Valve lift is not less than 1/15, but not more than 1/7 of the diameter of valve seat. The required areas of passages at the chest inlet and outlet are not to be less than the same and 2 times the required valve seat area respectively.
  - (2) Full bore type : Valve seat diameter is not less than 1.15 times throat diameter. The required area of passage at the valve seat is not to be less than 1.05 times the area at the throat, when the valve is open. Further, the minimum passage area at the outlet is not to be less than 2 times the area at the valve seat when the valve is open.
2. The construction of spring-loaded relief valves and the respective discharge pipes are to be in accordance with **Pt 5, Ch 5, 124.** of **Rules for the Classification of Steel Ships** or recognized standards as deemed appropriate by the Society.
3. The construction of the pilot type relief valves is to be as deemed appropriate by the Society. In such cases, those with non-metal diaphragms or membranes are to be in accordance with the following:
  - (1) Be capable of safely discharging vapour even when exposed to fire. Operating verification tests under fire conditions may be requested in cases where deemed appropriate by the Society.
  - (2) Valve lifting gear deemed appropriate by the Society is to be provided in cases where deemed necessary.
  - (3) Non-metallic membranes are to be durable for a period not less than 3 years.

---

---

## 904. Tests and inspections

### 1. Type tests

PRVs are to be type approved in accordance with accordance with **Ch 3, Sec. 15** of the **Guidance for Approval of Manufacturing Process and Type Approval, etc.**

### 2. Production tests

Each PRVs is to be tested in accordance with **Pt 7, Ch 5, 802. 5 (2)** of **Rules for the Classification of Steel Ships**

## Annex 2 Standard for the use of limit state methodologies in the design of fuel containment systems of novel configuration (2019)

### 101. General

1. The purpose of this standard is to provide procedures and relevant design parameters of limit state design of fuel containment systems of a novel configuration in accordance with **Ch 6, 416.** of the Rule.
2. Limit state design is a systematic approach where each structural element is evaluated with respect to possible failure modes related to the design conditions identified in **Ch 6, 401. 6** of the Rule. A limit state can be defined as a condition beyond which the structure, or part of a structure, no longer satisfies the regulations.
3. The limit states are divided into the three following categories:
  - (1) Ultimate Limit States (ULS), which correspond to the maximum load carrying capacity or, in some cases, to the maximum applicable strain, deformation or instability in structure resulting from buckling and plastic collapse; under intact (undamaged) conditions;
  - (2) Fatigue Limit States (FLS), which correspond to degradation due to the effect of cyclic loading; and
  - (3) Accident Limit States (ALS), which concern the ability of the structure to resist accident situations.
4. **Ch 6, 401.** through to **Ch 6, 414.** of the Rule are to be complied with as applicable depending on the fuel containment system concept.

### 102. Design format

1. The design format in this standard is based on a Load and Resistance Factor Design format. The fundamental principle of the Load and Resistance Factor Design format is to verify that design load effects,  $L_d$ , do not exceed design resistances,  $R_d$ , for any of the considered failure modes in any scenario:

$$L_d \leq R_d$$

- (1) A design load  $F_{dk}$  is obtained by multiplying the characteristic load by a load factor relevant for the given load category:

$$F_{dk} = \gamma_f \cdot F_k$$

where:

$\gamma_f$  = load factor; and

$F_k$  = the characteristic load as specified in **Ch 6, 409.** through to **412.** of the Rule

A design load effect  $L_d$  (e.g. stresses, strains, displacements and vibrations) is the most unfavorable combined load effect derived from the design loads, and may be expressed by:

$$L_d = q(F_{d1}, F_{d2}, \dots, F_{dN})$$

where

$q$  = the functional relationship between load and load effect determined by structural analysis.

- (2) The design resistance  $R_d$  is determined as follows:

$$R_d = \frac{R_k}{\gamma_R \cdot \gamma_C}$$

where:

$R_k$  = the characteristic resistance. In case of materials covered by **Ch 7** of the Rule, it may be, but not limited to, specified minimum yield stress, specified minimum tensile strength, plastic resistance of cross sections, and ultimate buckling strength;

$\gamma_R$  = the resistance factor, which is determined as follows

$$\gamma_R = \gamma_m \cdot \gamma_s;$$

where

$\gamma_m$  = the partial resistance factor to take account of the probabilistic distribution of the material properties(material factor)

$\gamma_s$  = the partial resistance factor to take account of the uncertainties on the capacity of the structure, such as the quality of the construction, method considered for determination of the capacity including accuracy of analysis; and

$\gamma_C$  is the consequence class factor, which accounts for the potential results of failure with regard to release of fuel and possible human injury.

- Fuel containment design is to take into account potential failure consequences. Consequence classes are defined in **Table 1.1**, to specify the consequences of failure when the mode of failure is related to the Ultimate Limit State, the Fatigue Limit State, or the Accident Limit State.

**Table 1.1 - Consequence classes**

Consequence class	Definition
Low	Failure implies minor release of the fuel.
Medium	Failure implies release of fuel and potential for human injury.
High	Failure implies significant release of the fuel and high potential for human injury/fatality

### 103. Required analyses

- Three-dimensional finite element analyses are to be carried out as an integrated model of the tank and the ship hull, including supports and keying system as applicable. All the failure modes are to be identified to avoid unexpected failures. Hydrodynamic analyses are to be carried out to determine the particular ship accelerations and motions in irregular waves, and the response of the ship and its fuel containment systems to these forces and motions.
- Buckling strength analyses of fuel tanks subject to external pressure and other loads causing compressive stresses are to be carried out in accordance with recognized standards. The method is to adequately account for the difference in theoretical and actual buckling stress as a result of plate out of flatness, plate edge misalignment, straightness, ovality and deviation from true circular form over a specified arc or chord length, as relevant.
- Fatigue and crack propagation analysis is to be carried out in accordance with **105. 1**.

### 104. Ultimate limit states

- Structural resistance may be established by testing or by complete analysis taking account of both elastic and plastic material properties. Safety margins for ultimate strength are to be introduced by partial factors of safety taking account of the contribution of stochastic nature of loads and resistance (dynamic loads, pressure loads, gravity loads, material strength, and buckling capacities).
- Appropriate combinations of permanent loads, functional loads and environmental loads including sloshing loads are to be considered in the analysis. At least two load combinations with partial load factors as given in **Table 1.2** are to be used for the assessment of the ultimate limit states.

**Table 1.2 Partial load factors**

Load combination	Permanent loads	Functional loads	Environmental loads
'a'	1.1	1.1	0.7
'b'	1.0	1.0	1.3

The load factors for permanent and functional loads in load combination 'a' are relevant for the normally well-controlled and/or specified loads applicable to fuel containment systems such as vapour pressure, fuel weight, system self-weight, etc. Higher load factors may be relevant for permanent and functional loads where the inherent variability and/or uncertainties in the prediction models are higher.

3. For sloshing loads, depending on the reliability of the estimation method, a larger load factor may be required by the Society.
4. In cases where structural failure of the fuel containment system are considered to imply high potential for human injury and significant release of fuel, the consequence class factor is to be taken as  $\gamma_C = 1.2$ . This value may be reduced if it is justified through risk analysis and subject to the approval by the Society. The risk analysis is to take account of factors including, but not limited to, provision of complete or partial secondary barrier to protect hull structure from the leakage and less hazards associated with intended fuel. Conversely, higher values may be fixed by the Society, for example, for ships carrying more hazardous or higher pressure fuel. The consequence class factor is to in any case not be less than 1.0.
5. The load factors and the resistance factors used are to be such that the level of safety is equivalent to that of the fuel containment systems as described in sections **Ch 6, 402. 1 to 5** of the Rule. This may be carried out by calibrating the factors against known successful designs.
6. The material factor  $\gamma_m$  is to in general reflect the statistical distribution of the mechanical properties of the material, and needs to be interpreted in combination with the specified characteristic mechanical properties. For the materials defined in **Ch 7** of the Rule, the material factor  $\gamma_m$  may be taken as:
  - 1.1 when the characteristic mechanical properties specified by the Society typically represents the lower 2.5% quantile in the statistical distribution of the mechanical properties; or
  - 1.0 when the characteristic mechanical properties specified by the Society represents a sufficiently small quantile such that the probability of lower mechanical properties than specified is extremely low and can be neglected.
7. The partial resistance factors  $\gamma_{si}$  are to in general be established based on the uncertainties in the capacity of the structure considering construction tolerances, quality of construction, the accuracy of the analysis method applied, etc.
  - (1) For design against excessive plastic deformation using the limit state criteria given in **8**, the partial resistance factors  $\gamma_{si}$  are to be taken as follows:

$$\gamma_{s1} = 0.76 \cdot \frac{B}{\kappa_1}$$

$$\gamma_{s2} = 0.76 \cdot \frac{D}{\kappa_2}$$

$$\kappa_1 = \text{Min} \left( \frac{R_m}{R_e} \cdot \frac{B}{A}; 1.0 \right)$$

$$\kappa_2 = \text{Min} \left( \frac{R_m}{R_e} \cdot \frac{D}{C}; 1.0 \right)$$

where

A, B, C and D = defined in **Ch 6, 415. 2 (3) (A)** of the Rule.

$R_m$  and  $R_e$  = defined in **Ch 6, 412. 1 (1) (C)** of the Rule.

The partial resistance factors given above are the results of calibration to conventional type B independent tanks.

**8. Design against excessive plastic deformation**

- (1) Stress acceptance criteria given below refer to elastic stress analyses.
- (2) Parts of fuel containment systems where loads are primarily carried by membrane response in the structure are to satisfy the following limit state criteria:

$$\begin{aligned}\sigma_m &\leq f \\ \sigma_L &\leq 1.5f \\ \sigma_b &\leq 1.5F \\ \sigma_L + \sigma_b &\leq 1.5F \\ \sigma_m + \sigma_b &\leq 1.5F \\ \sigma_m + \sigma_b + \sigma_g &\leq 3.0F \\ \sigma_L + \sigma_b + \sigma_g &\leq 3.0F\end{aligned}$$

where:

$\sigma_m$  = equivalent primary general membrane stress  
 $\sigma_L$  = equivalent primary local membrane stress  
 $\sigma_b$  = equivalent primary bending stress  
 $\sigma_g$  = equivalent secondary stress

$$f = \frac{R_e}{\gamma_{s1} \cdot \gamma_m \cdot \gamma_c}$$

$$F = \frac{R_e}{\gamma_{s2} \cdot \gamma_m \cdot \gamma_c}$$

The stress summation described above is to be carried out by summing up each stress component ( $\sigma_x$ ,  $\sigma_y$ ,  $\tau_{xy}$ ), and subsequently the equivalent stress is to be calculated based on the resulting stress components as shown in the example below.

$$\sigma_L + \sigma_b = \sqrt{(\sigma_{Lx} + \sigma_{bx})^2 - (\sigma_{Lx} + \sigma_{bx})(\sigma_{Ly} + \sigma_{by}) + (\sigma_{Ly} + \sigma_{by})^2 + 3(\tau_{Lxy} + \tau_{bxy})^2}$$

- (3) Parts of fuel containment systems where loads are primarily carried by bending of girders, stiffeners and plates, are to satisfy the following limit state criteria:

$$\sigma_{ms} + \sigma_{bp} \leq 1.25F \quad (\text{See notes 1,2})$$

$$\sigma_{ms} + \sigma_{bp} + \sigma_{bs} \leq 1.25F \quad (\text{See note 2})$$

$$\sigma_{ms} + \sigma_{bp} + \sigma_{bs} + \sigma_{bt} + \sigma_g \leq 3.0F$$

where:

$\sigma_{ms}$  = equivalent section membrane stress in primary structure  
 $\sigma_{bp}$  = equivalent membrane stress in primary structure and stress in secondary and tertiary structure caused by bending of primary structure  
 $\sigma_{bs}$  = section bending stress in secondary structure and stress in tertiary structure caused by bending of secondary structure  
 $\sigma_{bt}$  = section bending stress in tertiary structure  
 $\sigma_g$  = equivalent secondary stress

$$F = \frac{R_e}{\gamma_{s2} \cdot \gamma_m \cdot \gamma_c}$$

$\sigma_{ms}$ ,  $\sigma_{bp}$ ,  $\sigma_{bs}$  and  $\sigma_{bt}$  = defined in (4).

Note 1: The sum of equivalent section membrane stress and equivalent membrane stress in primary structure ( $\sigma_{ms} + \sigma_{bp}$ ) will normally be directly available from three-dimensional finite element analyses.

Note 2: The coefficient, 1.25, may be modified by the Society considering the design concept, configuration of the structure, and the methodology used for calculation of stresses.

Skin plates are to be designed in accordance with the requirements of the Society. When membrane stress is significant, the effect of the membrane stress on the plate bending capacity shall be appropriately considered in addition.

(4) Section stress categories

- (A) Normal stress is the component of stress normal to the plane of reference.
- (B) Equivalent section membrane stress is the component of the normal stress that is uniformly distributed and equal to the average value of the stress across the cross section of the structure under consideration. If this is a simple shell section, the section membrane stress is identical to the membrane stress defined in (2).
- (C) Section bending stress is the component of the normal stress that is linearly distributed over a structural section exposed to bending action, as illustrated in **Fig 1.1**.

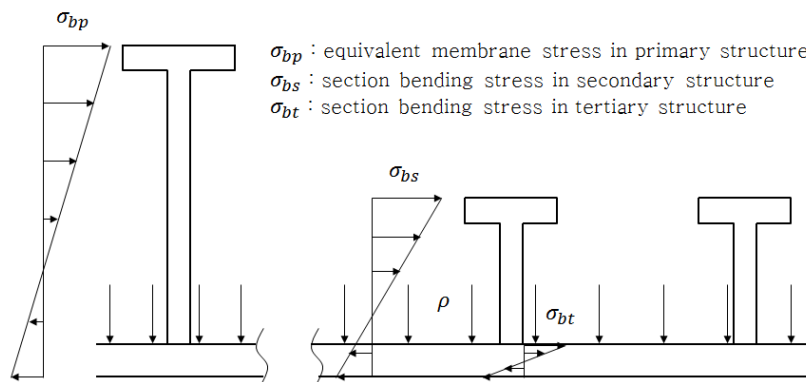

**Fig 1.1: Definition of the three categories of section stress**  
(Stresses  $\sigma_{bp}$  and  $\sigma_{bs}$  are normal to the cross section shown.)

9. The same factors  $\gamma_C$ ,  $\gamma_m$ ,  $\gamma_{si}$  shall be used for design against buckling unless otherwise stated in the applied recognized buckling standard. In any case the overall level of safety shall not be less than given by these factors.

**105. Fatigue limit states**

1. Fatigue design condition as described in **Ch 6, 412. 2** of the Rule shall be complied with as applicable depending on the fuel containment system concept. Fatigue analysis is required for the fuel containment system designed under **Ch 6 416.** and this standard.
2. The load factors for fatigue limit states shall be taken as 1.0 for all load categories.
3. Consequence class factor  $\gamma_C$  and resistance factor  $\gamma_R$  shall be taken as 1.0.
4. Fatigue damage shall be calculated as described in **Ch 6, 412. 2 (2) to (5)** of the Rule. The calculated cumulative fatigue damage ratio for the fuel containment systems shall be less than or equal to the values given in **Table 1.3**.

**Table 1.3 - Maximum allowable cumulative fatigue damage ratio**

$C_W$	Consequence class		
	Low	Medium	High
	1.0	0.5	0.5*
* Lower value shall be used in accordance with <b>Ch 6, 412. 2 (7) to (9)</b> of the Rule, depending on the detectability of defect or crack, etc.			

5. Lower values may be fixed by the Society.
6. Crack propagation analyses are required in accordance with **Ch 6, 412. 2 (6) to (9)** of the Rule. The analysis is to be carried out in accordance with methods laid down in Guidelines on Assessment of fatigue and crack propagation for High Manganese Steel developed by the Society.

### 106. Accident Limit States

1. Accident design condition as described in **Ch 6, 412. 3** of the Rule is to be complied with as applicable, depending on the fuel containment system concept.
2. Load and resistance factors may be relaxed compared to the ultimate limit state considering that damages and deformations can be accepted as long as this does not escalate the accident scenario.
3. The load factors for accident limit states are to be taken as 1.0 for permanent loads, functional loads and environmental loads.
4. Loads mentioned in **Ch 6, 409. 3 (3) (H)** and **5** of the Rule need not be combined with each other or with environmental loads, as defined in **Ch 6, 409. 4** of the Rule.
5. Resistance factor  $\gamma_R$  is to in general be taken as 1.0.
6. Consequence class factors  $\gamma_C$  are to in general be taken as defined in **104. 4** of this standard, but may be relaxed considering the nature of the accident scenario.
7. The characteristic resistance  $R_k$  is to in general be taken as for the ultimate limit state, but may be relaxed considering the nature of the accident scenario.
8. Additional relevant accident scenarios are to be determined based on a risk analysis.

### 107. Testing

Fuel containment systems designed according to this standard are to be tested to the same extent as described in **Ch 16, Sec 2**, as applicable depending on the fuel containment system concept.

## Annex 3 Risk assessment (2019)

### Section 1 General

#### 101. General

To help eliminate or mitigate risks a risk assessment is required by this Rules. In this regard it requires that the risk assessment is undertaken using acceptable and recognised techniques, and the risks and their mitigation are documented to the satisfaction of the Society.

It is recognised that there are many acceptable and recognised techniques and means to document a risk assessment. As such, it is not the intent of this document to limit a risk assessment to a particular technique or means of documentation. This document does, however, describe recommended practice and examples to help satisfy this Rules.

#### 102. Objective

The objective or goal of the risk assessment, as noted in this Rules, is to help “eliminate or mitigate any adverse effect to the persons on board, the environment or the ship”. That is, to eliminate or mitigate unwanted events related to the use of low-flashpoint fuels that could harm individuals, the environment or the ship.

#### 103. Scope

1. This Rules requires the risk assessment to cover the use of low-flashpoint fuel. The following items may be considered in the risk assessment.
  - (1) Equipment installed on board to receive, store, condition as necessary and transfer fuel to one or more engines, boilers or other fuel consumers;  
Such equipment includes manifolds, valves, pipes/lines, tanks, pumps/compressors, heat exchangers and process instrumentation from the bunker manifold(s) to delivery of fuel to the consumers.
  - (2) Equipment to control the operation;  
For example, pressure and temperature regulators and monitors, flow controllers, signal processors and control panels.
  - (3) Equipment to detect, alarm and initiate safety actions;  
For example, detectors to identify fuel releases and subsequent fires, and to initiate shutdown of the fuel supply to consumers.
  - (4) Equipment to vent, contain or handle operations outside of that intended (i.e. outside of process norms);  
For example, vent lines, masts and valves, overflow tanks, secondary containment, and ventilation arrangements.
  - (5) Fire-fighting appliances and arrangements to protect surfaces from fire, fuel contact and escalation of fire;  
For example, water sprays, water curtains and fire dampers.
  - (6) Equipment to purge and inert fuel lines;  
For example, equipment to store and supply nitrogen for the purposes of purging/inerting bunker lines, and equipment used for the safe transfer/disposal of fuel.
  - (7) Structures and constructions to house equipment;  
For example, fuel storage hold spaces, tank connection spaces and fuel preparation rooms.
2. The scope can exclude items that have been previously subjected to a risk assessment, provided there are no changes to ‘context of use’ and mitigation measures taken as a result of previous risk assessment are to be included. This can help reduce assessment time and effort.

The term ‘context of use’ (used above) refers to differences, such as differences in design or arrangement, installed location, mode of operation, use of surrounding spaces, and the number and type of persons exposed. For example, if an item is located on a cargo ship on-deck, it is a change to the ‘context of use’ if the same item is then installed below deck on a passenger ship. In addressing ‘context of use’ it is important to recognise that these ‘differences’ can significantly decrease or increase risk resulting in the need for fewer, more, changed or alternative means to eliminate or mitigate the risks.

3. With regards to liquefied natural gas (LNG), the this Rules states that risk assessment “need only be conducted where explicitly required by **Ch 5, Sec. 10 1001. 5, Ch 5 Sec. 12 1201. 3, Ch 6 Sec.4 401. 1, Ch 6 Sec.4 415. 4 (7) (B), Ch 8 Sec. 3 301. 1, Ch 13 Sec. 4, 401. 1, Ch 13 Sec.7 701. and Ch 15 Sec.8 801. 1 (10)** as well as by paragraphs **104. 4** and **106. 8** of the **annex 2**”. Hence, the this Rules allows the scope of the risk assessment to be limited to these paragraphs. It is important to note that there are differences of opinion on the scope of risk assessment required by these paragraphs. Therefore, the views of stakeholders and approval by the Society should be sought when finalising the scope of the risk assessment.
4. The risk assessment includes consideration of bunkering equipment installed on board but does not cover the bunkering operation of: ship arrival, approach and mooring, preparation, testing and connection, fuel transfer, and completion and disconnection. Bunkering of fuel is the subject of separate assessment as per ISO/TC18683 and reference should be made to appropriate and specific guidance.
5. This Rules requires that consideration is given to physical layout, operation and maintenance. Typically, the risks associated with maintenance are controlled by job specific risk assessments before the activity is undertaken. Therefore, consideration of maintenance is taken to mean high-level consideration of design and arrangements to facilitate a safe and appropriate working environment. This requires consideration of, for example, equipment isolation, ventilation of spaces, emergency evacuation, heating and lighting, and access to equipment. The purpose of this is to minimise the likelihood of unwanted events resulting in harm during maintenance. In addition, the purpose is to minimise the likelihood of unwanted events after maintenance, as a result of deficient work where a contributory cause was ‘a poor working environment’.
6. The assessment should also appreciate potential systems integration issues such as equipment control and connection compatibility. This is particularly important where a number of stakeholders are involved in separate elements of design, supply, construction and installation.
7. Occupational risks can be excluded from the risk assessment. They are an important safety consideration and are expected to be covered by the safety management system of the ship. The scope should obviously cover the design and arrangement as installed on board. Therefore, where the risk assessment is undertaken prior to finalising the design, it may require revision to ensure that the risks remain ‘mitigated as necessary’.
8. This Rules makes no reference to periodic update of the risk assessment. This should be undertaken where changes to the design/arrangement and/or its operation have been made, and in response to changes in performance of equipment and controls. This helps ensure the risks are ‘mitigated as necessary’ through-out the life of the fuel system. The final scope of the risk assessment should be agreed with appropriate Society and guided by applicable **Rules for the Classification of Steel Ships** and the this Rules.

#### 104. Approach

IMO has published guidance on formal safety assessment (FSA) and this provides useful information on risk assessment approaches and criteria<sup>5</sup>. The purpose of the guidance is to help evaluate new regulations on maritime safety and protection of the environment. In this regard, assessment is focused on risk quantification and cost benefit analysis to inform decision-making. As such, it is a useful reference to IMO’s views on risk assessment and criteria. However, the this Rules does not require a quantitative measure of risk to people, the environment or assets from the use of fuel. The risk assessment is simply required to provide information to help determine if further measures are needed to ‘eliminate’ risks or to ensure they are ‘mitigated as necessary’. Therefore, a qualitative or semi-quantitative approach to the risk assessment is appropriate (i.e. Qualitative Risk Assessment, QualRA). That is not to say that a fully quantitative approach is inappropriate or that circumstances might not favour its use (i.e. Quantitative Risk Assessment, QRA). What is important is that the risk assessment is of sufficient depth to help demonstrate that risks have been ‘eliminated’ or ‘mitigated as necessary’.

As a minimum, the risk assessment should detail:

- how the low-flashpoint fuel could potentially cause harm – Hazard identification;  
That is, systematic identification of unwanted events that could result in, for example, major injuries or fatality, damage to the environment, and/or loss of structural strength or integrity of the ship.
- the potential severity of harm – Consequence analysis;  
That is, the potential severity of harm (i.e. consequences) expressed in terms of, for example, major injuries, single and multiple fatalities, adverse environmental impact, and structural/ship damage sufficient to compromise safe operations.
- the likelihood of harm – Likelihood analysis;  
That is, the probability or frequency with which harm might occur.
- a measure of risk – Risk analysis;  
That is, a combination of consequence (2) and likelihood (3).
- judgements on risk acceptance – Risk assessment.  
The measure of risk (4) should be compared against criteria to judge if the risk has been ‘mitigated as necessary’. Acceptable and recognised techniques to address the requirements noted above (i.e. A-D) are described in, for example, ISO 310107, ISO 177768, ISO 169019, NORSOK Z-01310, CPR 12E11, and publications by CCPS12 and HSE13, etc.  
The following 1, outlines an approach to meeting the above requirements.

## 1. An approach to satisfying the this Rules requirements – Qualitative Risk Assessment (QualRA)

### (1) Hazard identification

- (A) Divide the fuel system into discrete parts with respects to equipment function and location.  
This promotes systematic consideration of each part of the system and helps identify specific causes of unwanted events related to a particular item, activity or section. A typical division of the system might be, for example:
- (a) the bunker station and fuel lines to the storage tank;
  - (b) the fuel storage hold space;
  - (c) the tank connection space;
  - (d) the fuel preparation room; and
  - (e) the fuel lines and valves ‘regulating’ fuel delivery to the engine.
- (B) Develop a set of guidewords/phrases and example causes that could result in unwanted events (e.g. a release of fuel or fuel system failure resulting in loss of power).
- (C) By reference to design and arrangement information, location plans, process flow diagrams, mitigation measures and planned emergency actions use the prompts to identify potential causes of unwanted events (e.g. fuel releases and loss of power).  
The prompts are used to stimulate discussion and ideas within a workshop led by a facilitator and attended by subject matter experts (SMEs).
- (D) Record the potential causes of unwanted events and mitigation measures

### (2) Consequence analysis

- (A) For each identified cause, estimate the potential consequences in terms of, for example, major injuries, single and multiple fatalities, adverse environmental impact and damage sufficient to compromise safe operations. The potential consequences can be estimated by the SMEs using judgement and reference to:
- (a) the fuel’s properties/hazards: The properties and hazards of liquefied natural gas (LNG) noted in (a) are summarised in **Sec.2**.
  - (b) the release location;
  - (c) dispersion/leak pathways;
  - (d) location and ‘strength’ of ignition sources;
  - (e) proximity of vulnerable receptors;
  - (f) generic or (if commissioned) specific fire and explosion modelling; and (f) expected effectiveness of existing/planned mitigation measures.
- (B) Categorise the consequence estimates.  
The consequences can be categorised by the SMEs to provide an indication of severity. For example, categories for harm to persons can distinguish between major injury, single fatality and multiple fatalities.

- (3) Likelihood analysis
- (A) Estimate the annual likelihood of occurrence of ‘cause and consequence’.
- Likelihood can be estimated by the SMEs (or a suitably qualified individual) for each ‘cause-consequence’ pair or a grouping of causes with the same consequence. The estimation can be informed by reference to accident and near-miss reports, accident and equipment release data, analogy to accidents in similar or other industries and consideration of the reliability and effectiveness of mitigation measures. It is not always apparent if the likelihood of a ‘cause-consequence’ combination is credible (i.e. reasonably foreseeable). An unwanted event may be considered credible if:
- it has happened before and it could happen again;
  - it has not happened but is considered possible with an annual likelihood of 1 in a million or more; and
  - it is planned for, that is, emergency actions cover such a situation or maintenance is undertaken to prevent it.
- (B) Categorise the likelihood estimates.
- Likelihood can be categorised by the SMEs (or a suitably qualified individual) to provide an indication of accident/incident occurrence or other unwanted event occurrence.
- (4) Risk analysis
- (A) Estimate the risk.
- Risk can be estimated by the SMEs (or a suitably qualified individual) by combining the consequence and likelihood categories to provide a risk rating.
- (5) Risk assessment
- (A) Judge if the risk has been ‘mitigated as necessary’.
- The estimated risk can be compared against risk criteria embedded within a risk matrix. The matrix shows the risk rating (with respects to consequence and likelihood) and the criteria illustrate whether the risk has been ‘mitigated as necessary’.
- Practically, the risk rating is an indication that additional or alternative mitigation measures:
- Unacceptable rating: must be provided; or
  - Manageable rating: must be considered and implemented if practical and cost effective; or
  - Negligible rating: need not be considered further, beyond accepted good practice of reducing risk where practicable.

## 2. Mitigated as necessary

- (1) Essentially, a risk is considered ALARP if all reasonably practicable mitigation measures have been implemented. This means that additional or alternative measures have been identified and implemented unless they are demonstrated as impractical or the cost of implementation is disproportionate to the reduction in risk. This concept of ALARP is established practice in many industries and recognised as best practice by IMO.
- (2) Best practice:
- (A) Measures to prevent an unwanted event;
- That is, to ensure the unwanted event cannot occur or its likelihood of occurrence is greatly reduced;
- (B) Measures to protect against harm given an unwanted event.
- That is, to reduce the consequences after the unwanted event has occurred.
- (3) In addition, when considering mitigation measures it is good practice to consider engineering solutions in preference to procedural controls. This helps promote an inherently safer design. Furthermore, it is good practice to consider passive measures in preference to active measures. Examples of mitigation measures are listed in **Sec.3**.
- (4) To help judge if mitigation measures are effective it can be useful to illustrate or map the pathway from ‘cause’ to ‘consequence’ and review the effectiveness of the mitigation measures.
- (5) Whether a single mitigation measure or a collection of mitigation measures is practical and cost-effective is in some respects relative to the resources and skills available. If the SMEs cannot decide then the use of cost benefit analysis can be helpful. In any case, a documented justification for not implementing a mitigation measure should be made where SMEs judge the measure to be practical and cost-effective.

## 105. Team

The team conducting the risk assessment should comprise of subject matter experts (SMEs) who are, collectively, suitably qualified and experienced. For the QualRA noted above, this means the workshop team includes individuals who are degree qualified and/or chartered/professional engineers, have operational ship experience and are experienced in risk assessment. Such qualifications and experience should be in relevant disciplines to cover engineering design and safe use of the fuel.

It is unlikely that one SME can satisfy the above team requirements. In any case, to ensure investigative discussion, generation of ideas, for example, mechanical, process, electrical and operational aspects, a typical number of SMEs might be four to eight.

In addition to the SMEs, the team should be led by a facilitator (also referred to as the chair or chairman). The facilitator should be impartial with no vested interests in the fuel system, and experienced in leading such risk assessments. The facilitator may be supported by a scribe (also referred to as a secretary) to aid reporting.

The time expended by the team depends upon the agreed scope and the designs' 'complexity'. For example, a QualRA workshop for a new design might require two or three working days, whereas, a minor variation to a previously assessed and approved design might require only half a day.

## 106. Reporting

### 1. Main report

A written report documenting the risk assessment should be produced. This needs to be sufficiently detailed to support results, conclusions, recommendations and any actions taken. This is because the assessment will inform important design and operational decisions. Furthermore, the report is a record in helping to demonstrate 'mitigated as necessary'. A report only consisting of a completed worksheet is insufficient.

The specific contents of the report and its structure are dependent upon design and assessment specifics, and reporting preferences. However, for a QualRA, the report should provide:

- (1) An overview of the design and arrangement;  
This is a simple explanation of the design and arrangement with respects to its intended operation and process conditions. Technical appendices should include process flow diagrams, general arrangement plans and all information used during the assessment. Where this is too cumbersome to include in the report in full, reference to this material is sufficient provided it remains accessible.
- (2) An explanation of the risk assessment process;  
This is a description of the risk assessment method and includes how the design was divided into parts for assessment, how hazard identification was undertaken, and the selection of consequence and likelihood categories and risk criteria.
- (3) Information on the relevant qualifications and expertise of the team;  
This can be a table listing the names, job titles, relevant qualifications, expertise and experience of all team members (including the facilitator and scribe).
- (4) Risk results and conclusions;  
This is a listing or discussion of the results and a judgement on whether or not the risk has been 'mitigated as necessary'.
- (5) Recommendations and actions.  
This can include requests for modelling and analysis (e.g. gas dispersion or thermal radiation extent, etc.) and will most likely include additional and alternative mitigation measures to be investigated and/or implemented, who is responsible for these and, if known, an expected completion date.

## Section 2 Properties & Hazards of Liquefied Natural Gas

### 201. LNG Properties

Liquefied natural gas (LNG) is a cryogenic liquid. It consists of methane with small amounts of ethane, propane and inert nitrogen. When used as a fuel, typically 94% or more is methane. Stored at ambient or near ambient pressure, its temperature approximates minus 162 deg.C and its specific gravity is about 0.42. Hence, if released onto the sea LNG floats (and can rapidly 'boil' – refer to 3.2.7). When stored at pressures of up to 10 bar the temperature typically remains below minus 130 deg.C with a specific gravity of approximately 0.4.

Released into atmospheric conditions, LNG rapidly boils forming a colourless, odourless and non-toxic gas. Although colourless, due to its very low temperature, water vapour in the air condenses forming a visible mist or cloud. The cold gas is initially heavier than air and it remains negatively buoyant until its temperature rises to about minus 100 deg.C. At this stage the gas becomes lighter than air, and in an open environment it is thought that this coincides with a gas concentration of less than 5%. At this temperature and concentration the gas is still within the visible cloud. As the gas continues to warm to ambient conditions its volume is approximately 600 times that of the liquid with a relative vapour density of about 0.55, and so the gas is much lighter than air (air = 1).

As the gas disperses, its concentration reduces. At a concentration in air of between 5% and 15% the mix is flammable and can ignite in the presence of ignition sources or in contact with hot sources at or above a temperature of approximately 595 deg.C (referred to as the auto-ignition temperature). Once below a concentration of 5% the mix is no longer flammable and cannot be ignited (and this is the case if the concentration remains above 15%). The 15% and 5% concentrations of LNG in air are commonly known as the upper and lower flammability limits, respectively. More recently, the limits are referred to as the upper and lower explosion limits, although ignition may not necessarily result in explosion.

### 202. LNG Hazards

#### 1. Cryogenic burns

Owing to its very low liquid temperature, in contact with the skin LNG causes burns. In addition, breathing the cold gas as it 'boils' can damage the lungs. The severity of burns and lung damage is directly related to the surface area contacted by the liquid/gas and duration of exposure.

#### 2. Low temperature embrittlement

In contact with low temperature LNG, many materials lose ductility and become brittle. This includes carbon and low alloy steels typically used in ship structures and decking. Such low temperature embrittlement can result in material fracture, such that existing stresses in the contacted material cause cracking and failure even without additional impact, pressure or use. For LNG duty, materials resistant to low temperature embrittlement are used. These materials include stainless steel, aluminium, and alloy steels with a high-nickel content.

#### 3. Asphyxiation

LNG is non-toxic and is not a known carcinogen. However, as it boils to gas it can cause asphyxiation as it displaces and then mixes with the surrounding air. The likelihood of asphyxiation is related to the concentration of gas in air and duration of exposure.

#### 4. Expansion and pressure

Released into the atmosphere LNG will rapidly boil with the volume of gas produced being hundreds of times that of the liquid (approximately 600 times at ambient conditions). Hence, if confined and unrelieved, the pressure will increase and this can damage surrounding structures and equipment.

## 5. Fire

### (1) Pool fire

A 'small' release of LNG will rapidly boil and 'flash' to gas (i.e. evaporate). However, given a 'large' and sudden release, a cold pool of LNG will form with gas boiling from the pool and mixing and dispersing with the surrounding air. If this mix is within the flammable range (i.e. 5% to 15% with air) and contacts an ignition source or a heated surface above the auto-ignition temperature (595 deg.C) it will ignite and the resultant flame will 'travel back' to the pool resulting in a pool fire.

### (2) Jet fire

If stored under pressure then a release of LNG may discharge as a jet of liquid, entraining, vapourising and mixing with air. If the mix disperses and reaches an ignition source or a heated surface (above the auto-ignition temperature) whilst in the flammable range it will ignite. The resultant flame will 'travel back' and may result in a pressurised jet fire from the release source. Similarly, where contained LNG has been heated to form gas, a pressurised release of this gas could ignite and result in a jet fire.

### (3) Flash fire

Release of LNG to atmosphere and ignition within a few tens of seconds is likely to result in a pool fire or jet fire (as noted above) with no damaging overpressure. This is because the flammable part of the cloud is likely to be relatively small and close to the release point upon ignition. However, if ignition is delayed, the gas cloud will be larger and may have travelled further from the release point. Ignition will then result in a flash fire as the flammable part of the cloud is rapidly consumed within a few seconds. This ignition is likely to be violent and audible, and is often mistaken for an explosion, although there is little appreciable overpressure.

### (4) Thermal radiation from a pool fire, jet fire and flash fire

Harm to people and damage to structures and equipment from fire is dependent upon the size of the fire, distance from the fire, and exposure duration. Within a metre of the fire, thermal radiation may approximate 170 kW/m<sup>2</sup> but this rapidly falls with distance from the fire.

As a rough guide:

- 6 kW/m<sup>2</sup> or more and escape routes are impaired and persons only have a few minutes or less to avoid injury or fatality<sup>16</sup>;
- 35 kW/m<sup>2</sup> results in immediate fatality<sup>16</sup>;
- 37.5 kW/m<sup>2</sup> has long been considered as the onset of damage to industrial equipment and structures exposed to a steady state fire<sup>17</sup>;
- industrial equipment and structures within a flash fire are unlikely to be significantly damaged; and
- persons within a pool, jet or flash fire are likely to be fatally injured.

An LNG fire on a ship could result in fatalities and damage to equipment and structures (including the hull).

## 6. Explosion

Release of LNG to atmosphere and delayed ignition of the resultant flammable cloud beyond a few tens of seconds can result in an explosion. This is because the cloud may have dispersed in and around equipment and structures causing a degree of confinement and increased surface area over which to increase flame speed as it travels (i.e. burns) through the flammable mixture. The resultant overpressure may be sufficient to harm individuals, and damage structures and equipment. Such an explosion is most likely to be a deflagration (rather than a detonation), categorised by high-speed subsonic combustion (i.e. the rate at which the flame travels through the flammable cloud).

### (1) Overpressure from an explosion

Harm to people and damage to structures and equipment from an explosion is dependent upon the magnitude of overpressure generated and the rate at which the overpressure is delivered (known as impulse). In addition, harm is often a result of falling or being thrown against hard surfaces or being struck by objects and debris as a result of the blast.

### (2) As a rough guide:

- the probability of fatality from exposure to an explosion of 0.25 bar and 1 bar is about 1% and 50%, respectively<sup>18</sup>;
- less than 0.25 bar could throw an individual against a hard surface resulting in injury or fatality<sup>18</sup>; and
- 0.3 bar is typically the limit of damage to structures and industrial equipment.

An explosion of vapourised LNG on a ship could result in fatalities and damage to equipment and structures (including the hull).

### 7. Rapid phase transition

Upon release, LNG rapidly boils due to heat from the surrounds, be this from the air, water/sea, steel or ground. However, this rapid and sometimes violent boiling is not rapid phase transition (RPT); RPT is an explosive vaporisation of the liquid, that is, a near instantaneous transition from liquid to gas. This is a more violent event than rapid boiling and it can result in liquid ejection and damaging overpressure<sup>19</sup>. The phenomenon is well known in the steel industry, where accidental contact between molten metal and water can result in RPT.

### 8. Rollover

Slowly, stored refrigerated LNG evaporates (i.e. 'boils-off') as heat from the surrounds gradually 'leaks' into the tank. Essentially, liquid in contact with the wall of the tank warms, becomes less dense and rises to the top. This top-layer then begins to evaporate (i.e. boil-off) increasing the liquid layer's density. Liquid further away from the walls also warms but at a slower rate and because of this a less dense layer below the top layer forms. Owing to the hydrostatic head, the saturation condition of this layer changes and although it heats-up, it does not evaporate but remains in the liquid state and becomes 'superheated'. As the heating continues, the trapped layer's density reduces; this is an unstable state and when the density of this layer is similar to the top layer the two layers rapidly mix and the superheated lower layer vaporises. This rapid mixing and vaporisation is known as rollover and can cause damaging over-pressure and release of gas if not appropriately controlled.

The heating mechanism described above can result in a number of differing layers and is referred to as stratification. It is a phenomenon that is well known and is safely managed through venting, mixing and temperature control.

The above phenomenon is hastened by, or can directly occur when differing densities of LNG are bunkered.

Table 1 Comparison of the Hazards of LNG and Fuel Oil

Hazard	LNG	Fuel Oil
<b>1. Cryogenic Burns</b> Liquid contact with skin will cause burns and can result in fatality. Inhalation of gas can cause burns to the lungs and lead to fatal injury.	○	×
<b>2. Low Temperature Embrittlement</b> Equipment/structures can fail on contact with liquid.	○	×
<b>3. Rapid Phase Transition (RPT)</b> Released onto the sea a near instantaneous 'explosive' transition from liquid to gas can occur. This can result in structural damage to the hull.	○	×
<b>4. Gas Expansion</b> A liquid pool rapidly boils, and as the gas warms and expands it requires a volume 600 times that of the liquid. This can result in equipment damage.	○	×
<b>5. Asphyxiation</b> In a confined space, displacement and mixing of the gas in the air will reduce oxygen content and can cause asphyxiation.	○	○
<b>6. Pool Fire</b> Gas/vapour above the pool can ignite resulting in a pool fire. The intensity of the radiation can cause fatal injury and fail structure and critical equipment.	○	○
<b>7. Flash Fire</b> Gas/vapour can disperse away from the pool and ignite resulting in a flash fire. The short-duration and intense radiation can instigate secondary fires, and cause fatal injuries to those within the fire and to critical equipment. Most probably the fire will burn back to the pool and result in a pool fire.	○	×
<b>8. Explosion</b> Gas/vapour can disperse and collect in confined areas and ignite resulting in an explosion. The explosion can cause fatal injuries, instigate secondary fires, and fail structure and critical equipment. Most probably the explosion will burn back to the pool/gas source and result in a pool fire or jet fire.	○	×
<b>9. Rollover</b> Stored liquid can stratify, that is different layers can have different densities and temperatures. This can cause the layers to 'rollover' resulting in significant gas/vapour generation that must be contained. If released, this can result in flash fire or explosion.	○	×
<b>10. Boil-off Gas (BoG)</b> LNG continually boils and must be re-liquefied or burnt-off. A release of BoG can ignite and result in a jet fire (given sufficient release pressure), flash fire or explosion.	○	×
(Note) 1. Fuel oil means heavy fuel oil(HFO)(ISO 8217)		

## Section 3 Example mitigation measures

### 301. General

Within this Rules, measures to reduce likelihood and measures to reduce consequences are both understood to be mitigation measures (i.e. they mitigate the risk). To align with this Rules, this understanding is maintained within this document. It is recognised that in many other industries it is common to use the terms 'prevention measures' and 'mitigation measures', where the former reduces likelihood and the latter reduces consequences. Prevention and mitigation measures are often referred to as 'safeguards' or 'barriers'.

### 302. Engineering Mitigation Measures

1. Protection from mechanical impact damage
2. Protection from vibration / vibration monitoring
3. Protection from wind, waves and weather
4. Pressure relief, venting
5. Increased separation or increased physical protection from collision / grounding
6. Secondary containment (e.g. double-walled pipework)
7. Welded connections in preference to flanged connections
8. Alarmed and self-closing doors
9. Bulkhead separation / cofferdam
10. Drip tray capacity, liquid detection
11. Spray shield coverage
12. Protection of structure from cryogenic temperatures and pressure from evolved vapour / gas
13. Independent bilge
14. Fire and gas detection, monitoring, audible / visual alarm and shutdown
15. Pressure and temperature detection, audible / visual monitoring, alarm and shutdown
16. Level detection
17. Forced / natural ventilation - airlock
18. Minimisation of ignition sources - Ex proof electrical equipment
19. Fire-fighting fire and cooling appliances - foam, water spray
20. Fire dampers
21. Separation of spaces
22. Access arrangements
23. Physical shielding
24. Mooring tension monitoring / alarm
25. Strain monitoring of supports
26. Buffer/overflow tank - Fuel recycling
27. Independent safety critical controls to IEC 61508
28. Radar monitoring
29. Service fluid - level / gas detection, alarm and shutdown
30. Flame arrestor

**303. Procedural Mitigation Measures**

1. Increased frequency of inspection (and maintenance)
2. Reduced parts replacement frequency
3. Specific training for low-flashpoint fuels
4. Restricted access
5. Monitoring

---

---

**RULES AND GUIDANCE FOR THE  
CLASSIFICATION OF SHIPS  
USING LOW-FLASHPOINT FUELS**

Published by

**KR**

36, Myeongji ocean city 9-ro, Gangseo-gu,  
BUSAN, KOREA

TEL : +82 70 8799 7114

FAX : +82 70 8799 8999

Website : <http://www.krs.co.kr>

---

---

Copyright© 2019, **KR**

Reproduction of this Rules and Guidance in whole or in  
parts is prohibited without permission of the publisher.